



**NONRESIDENT
TRAINING
COURSE**



March 1990

Aircrew Survival Equipmentman 2

NAVEDTRA 14218

Although the words “he,” “him,” and “his” are used sparingly in this course to enhance communication, they are not intended to be gender driven or to affront or discriminate against anyone.

PREFACE

By enrolling in this self-study course, you have demonstrated a desire to improve yourself and the Navy. Remember, however, this self-study course is only one part of the total Navy training program. Practical experience, schools, selected reading, and your desire to succeed are also necessary to successfully round out a fully meaningful training program.

THE COURSE: This self-study course is organized into subject matter areas, each containing learning objectives to help you determine what you should learn along with text and illustrations to help you understand the information. The subject matter reflects day-to-day requirements and experiences of personnel in the rating or skill area. It also reflects guidance provided by Enlisted Community Managers (ECMs) and other senior personnel, technical references, instructions, etc., and either the occupational or naval standards, which are listed in the *Manual of Navy Enlisted Manpower Personnel Classifications and Occupational Standards*, NAVPERS 18068.

THE QUESTIONS: The questions that appear in this course are designed to help you understand the material in the text.

VALUE: In completing this course, you will improve your military and professional knowledge. Importantly, it can also help you study for the Navy-wide advancement in rate examination. If you are studying and discover a reference in the text to another publication for further information, look it up.

*1990 Edition Prepared by
PRCM Harold G. Lyter*

Published by
NAVAL EDUCATION AND TRAINING
PROFESSIONAL DEVELOPMENT
AND TECHNOLOGY CENTER

**NAVSUP Logistics Tracking Number
0504-LP-022-3680**

Sailor's Creed

“I am a United States Sailor.

I will support and defend the Constitution of the United States of America and I will obey the orders of those appointed over me.

I represent the fighting spirit of the Navy and those who have gone before me to defend freedom and democracy around the world.

I proudly serve my country's Navy combat team with honor, courage and commitment.

I am committed to excellence and the fair treatment of all.”

CONTENTS

CHAPTER	Page
1. Personnel Parachute Familiarization	1-1
2. Automatic Opening Devices	2-1
3. NES-12 Personnel Parachute System	3-1
4. Aircrew Personal Protective Equipment	4-1
5. Rescue and Survival Equipment	5-1
6. Inflatable Survival Equipment..	6-1
7. Seat Survival Kit	7-1
8. Carbon Dioxide	8-1
9. Sewing Machines	9-1
10. Fabrication and Manufacture..	10-1
11. Oxygen Components Test Stands	11-1
12. Oxygen Related Components.	12-1
APPENDIX	
I. Glossary	AI-1
II. References	AII-1
INDEX	INDEX-1

INSTRUCTIONS FOR TAKING THE COURSE

ASSIGNMENTS

The text pages that you are to study are listed at the beginning of each assignment. Study these pages carefully before attempting to answer the questions. Pay close attention to tables and illustrations and read the learning objectives. The learning objectives state what you should be able to do after studying the material. Answering the questions correctly helps you accomplish the objectives.

SELECTING YOUR ANSWERS

Read each question carefully, then select the BEST answer. You may refer freely to the text. The answers must be the result of your own work and decisions. You are prohibited from referring to or copying the answers of others and from giving answers to anyone else taking the course.

SUBMITTING YOUR ASSIGNMENTS

To have your assignments graded, you must be enrolled in the course with the Nonresident Training Course Administration Branch at the Naval Education and Training Professional Development and Technology Center (NETPDTC). Following enrollment, there are two ways of having your assignments graded: (1) use the Internet to submit your assignments as you complete them, or (2) send all the assignments at one time by mail to NETPDTC.

Grading on the Internet: Advantages to Internet grading are:

- you may submit your answers as soon as you complete an assignment, and
- you get your results faster; usually by the next working day (approximately 24 hours).

In addition to receiving grade results for each assignment, you will receive course completion confirmation once you have completed all the

assignments. To submit your assignment answers via the Internet, go to:

<http://courses.cnet.navy.mil>

Grading by Mail: When you submit answer sheets by mail, send all of your assignments at one time. Do NOT submit individual answer sheets for grading. Mail all of your assignments in an envelope, which you either provide yourself or obtain from your nearest Educational Services Officer (ESO). Submit answer sheets to:

COMMANDING OFFICER
NETPDTC N331
6490 SAUFLEY FIELD ROAD
PENSACOLA FL 32559-5000

Answer Sheets: All courses include one “scannable” answer sheet for each assignment. These answer sheets are preprinted with your SSN, name, assignment number, and course number. Explanations for completing the answer sheets are on the answer sheet.

Do not use answer sheet reproductions: Use only the original answer sheets that we provide—reproductions will not work with our scanning equipment and cannot be processed.

Follow the instructions for marking your answers on the answer sheet. Be sure that blocks 1, 2, and 3 are filled in correctly. This information is necessary for your course to be properly processed and for you to receive credit for your work.

COMPLETION TIME

Courses must be completed within 12 months from the date of enrollment. This includes time required to resubmit failed assignments.

PASS/FAIL ASSIGNMENT PROCEDURES

If your overall course score is 3.2 or higher, you will pass the course and will not be required to resubmit assignments. Once your assignments have been graded you will receive course completion confirmation.

If you receive less than a 3.2 on any assignment and your overall course score is below 3.2, you will be given the opportunity to resubmit failed assignments. **You may resubmit failed assignments only once.** Internet students will receive notification when they have failed an assignment--they may then resubmit failed assignments on the web site. Internet students may view and print results for failed assignments from the web site. Students who submit by mail will receive a failing result letter and a new answer sheet for resubmission of each failed assignment.

COMPLETION CONFIRMATION

After successfully completing this course, you will receive a letter of completion.

ERRATA

Errata are used to correct minor errors or delete obsolete information in a course. Errata may also be used to provide instructions to the student. If a course has an errata, it will be included as the first page(s) after the front cover. Errata for all courses can be accessed and viewed/downloaded at:

<http://www.advancement.cnet.navy.mil>

STUDENT FEEDBACK QUESTIONS

We value your suggestions, questions, and criticisms on our courses. If you would like to communicate with us regarding this course, we encourage you, if possible, to use e-mail. If you write or fax, please use a copy of the Student Comment form that follows this page.

For subject matter questions:

E-mail: n315.products@cnet.navy.mil
Phone: Comm: (850) 452-1777
DSN: 922-1777
FAX: (850) 452-1370
(Do not fax answer sheets.)
Address: COMMANDING OFFICER
NETPDTC (CODE N315)
6490 SAUFLEY FIELD ROAD
PENSACOLA FL 32509-5237

For enrollment, shipping, grading, or completion letter questions

E-mail: n331@cnet.navy.mil
Phone: Comm: (850) 452-1511/1181/1859
DSN: 922-1511/1181/1859
FAX: (850) 452-1370
(Do not fax answer sheets.)
Address: COMMANDING OFFICER
NETPDTC (CODE N331)
6490 SAUFLEY FIELD ROAD
PENSACOLA FL 32559-5000

NAVAL RESERVE RETIREMENT CREDIT

If you are a member of the Naval Reserve, you will receive retirement points if you are authorized to receive them under current directives governing retirement of Naval Reserve personnel. For Naval Reserve retirement, this course is evaluated at 10 points. (Refer to *Administrative Procedures for Naval Reservists on Inactive Duty*, BUPERSINST 1001.39, for more information about retirement points.)

COURSE OBJECTIVES

In completing this nonresident training course, you will demonstrate a knowledge of the subject matter by correctly answering questions on the following: Personnel parachute familiarization; automatic opening devices; NES-12 personnel parachute system; protective equipment; rescue and survival equipment; inflatable survival equipment; seat survival kit; carbon dioxide; sewing machines; fabrication and manufacture; oxygen test stands and oxygen related components.

Student Comments

Course Title: Aircrew Survival Equipmentman 2

NAVEDTRA: 14218 **Date:** _____

We need some information about you:

Rate/Rank and Name: _____ SSN: _____ Command/Unit _____

Street Address: _____ City: _____ State/FPO: _____ Zip _____

Your comments, suggestions, etc.:

Privacy Act Statement: Under authority of Title 5, USC 301, information regarding your military status is requested in processing your comments and in preparing a reply. This information will not be divulged without written authorization to anyone other than those within DOD for official use in determining performance.

NETPDTC 1550/41 (Rev 4-00)

CHAPTER 1

PERSONNEL PARACHUTE FAMILIARIZATION

Learning Objective: Upon completion of this chapter, you will be able to recognize and understand the history, components, and publications used to maintain personnel emergency parachute assemblies.

The word *parachute* is, in the modern sense, derived from the Italian word *parare*, meaning to protect or shield from, and the French word *chute*, meaning a fall or quick descent—literally, “to protect from a fall.” As early as the year 1300, Chinese experimenters are reported to have jumped off the Great Wall with devices resembling umbrellas. In the year 1495, the great genius, artist, and inventor, Leonardo da Vinci, sketched a parachute design to be made of caulked linen that would permit a gentle descent to earth. About a century later, Fausto Veranzio described and sketched a parachute design consisting of a four-poled square frame covered with fabric, which he claimed could be used to escape from tall, burning buildings. Since man, not yet airborne, had no use for a lifesaving device of this nature at that time, parachutes were considered novelties or items of amusement, and interest in them gradually lessened. It was not until the invention of the first aerial balloon that interest in the parachute was renewed. As a result of the balloon, the parachute became less of a toy and more a means of escape.

In the late 1700's, the Montgolfier brothers had invented a balloon that would stay aloft. This balloon was kept in the air by burning bundles of straw beneath the bag to furnish the necessary supply of hot air. If the fabric caught fire, the flight was abruptly ended. This meant that those who went up on such flights had to have a means of escape. Those early days of ballooning saw excursions of curiosity into the use of parachutes by early balloonists such as the Montgolfiers, Blanchard, Martyn, Arnold, Appleby, Hampton, and others. Some parachute drops, using animals as passengers, were successfully made. The first human parachute descent was accomplished by the famous French balloonist Andre-Jacques Garnerin, on 22 October 1798. This historic event

took place over Monceau Park, near Paris, when Garnerin released himself and his semirigid parachute from the balloon at an altitude of 6,000 feet.

On 14 July 1808, a famous Polish balloonist, Jodaki Kuparento, was the first man to have his life saved from a flaming bag of hot air when, over Warsaw, remnants of his burning balloon blew into the balloon's net structure and blossomed into a parachute, lowering him to the ground safely. However, the need for a foolproof parachute-whose main role at that time was its use as an added thrill to balloon ascensions-was not strong enough to stimulate a great deal of inventive effort until nearly 100 years later. Hence, with the coming of the air age in 1903, when the Wright brothers made their spectacular flight at Kitty Hawk, North Carolina, there came also an era of experimentation with parachutes designed for this new type of flying machine.

Albert Berry is credited with being the first person to successfully jump from an aircraft using a parachute. This jump was made on March 1, 1912, from a Benoist Pusher Biplane, at Jefferson Barracks, not far from Kinloch Park “Aerodrome,” St. Louis. The parachute was an unbleached muslin cotton parachute, 36 feet in diameter. Its suspension lines terminated into a trapeze bar and strap arrangement. The parachute assembly was packed into a cone attached under the airplane. It was retained within the metal cone by a series of break cords. The weight of Berry's falling body pulled the canopy and lines from the container. Many others, using makeshift or experimental parachutes, made descents before World War I, but parachutes still were not considered essential equipment for military aviators. As World War I progressed, the resultant mortality rate among pilots was very high. However, the lives of over 800 balloonist

observers and artillery fire directors were saved by parachutes, demonstrating a desperate need for a foolproof and practical lifesaving device for aviators. The next step was to improve parachute reliability and make them mandatory for military fliers.

Parachute lore tells us that in 1917 a French pilot attacked a German Fokker and riddled it with bullets. The plane exploded in flames and began to plunge to earth. As the Frenchman circled his kill, he was surprised to see the enemy pilot jump, immediately followed by a ribbon of white swing out behind him as he fell through the clouds. Still amazed, he watched as a great billowing canopy fluttered and opened. The plummeting body slowed with a jerk and began swaying gently beneath the air-filled blossom. The adversary waved at the stunned victor and proceeded to swing into no man's land, where the reception was far from friendly. Twenty-seven rifle and machine gun bullets were pumped into the German's legs. He survived and gained the honor of being the first person to save his life by an emergency escape from an airplane.

Official documentation reveals that regular emergency bailouts were made during the late months of 1918 by German aviators. Captured equipment showed the parachute to be a unique one designed by Heineke. Gradually, German fighter pilots began to equip themselves with parachutes. Soon, whole squadrons were doing the same. At the end of the war, it was reported that all fliers in the entire German Air Force were in the process of wearing parachutes in flight.

All parachutes, however clever in design, were still dependent upon a static line attached to the aircraft to deploy the parachute, and they were far from perfect. Thus, some emergency escape attempts continued to take lives. Towards the end of 1918, with the war coming to a close, demands by the flying public and Congress finally resulted in the formation of a U.S. Air Service Parachute Board at McCook Field in Dayton, Ohio. Floyd Smith, with a reputation for his ideas in parachute design, was put in charge of this new unit of the Engineering Division. He surrounded himself with Guy M. Ball, James M. Russel, James J. Higgins, and Sgt. Ralph W. Bottreil. At the beginning of 1919, energetic Major E. L. Hoffman was chosen as military head of this parachute development team.

The "crash program" produced results. Parachutes from all over the world, all attached (static-line actuated) types, were tested and found to be unsafe and weak, and otherwise unsuitable

for use in emergency jumps from airplanes. Initial testing on a new parachute design devised by Floyd Smith showed potential. This concept involved the use of a parachute canopy and lines packed into a container worn on a body harness, using a manually operated ripcord, yanked while falling freely through the air with no attachment to the aircraft, to open the parachute. Floyd Smith, with Guy Ball working closely at his side, worked together to perfect this new revolutionary parachute.

This parachute ultimately became the U.S. Air Service Airplane Parachute, type A. It had a 28-foot diameter silk canopy with silk suspension lines. The canopy was formed of 40 gores, with a novel shock-reducing vent design, and it was packed into a backpack container worn on the body of the flyer, by being attached to a webbing harness. A small pilot-chute was used to deploy the packed canopy and lines into the air when a pull on the ripcord opened the flaps on the back container being worn on the body. Not being dependent on any attachment to the aircraft for operation, it allowed the aviator to leave his disabled aircraft regardless of its position. It was capable of withstanding an opening shock delivered by 200 pounds falling at a speed of 400 miles per hour.

When Major Hoffman felt that it was time for the Model A parachute to be live-jumped, he chose a young, enthusiastic parachutist and designer named Leslie L. Irvin because of his vast experience as a parachute jumper. Irvin had responded to the government's call for a suitable parachute, and submitted a static-line operated parachute assembly with a cotton canopy. He was apprised that the submitted parachute was unsuitable because by that time the use of a silk canopy, as well as the ripcord concept, was considered preferable. Irvin continued to cooperate with the board by supplying parachute items. On April 28th, 1919, flying in a USD-9 airplane piloted by Floyd Smith at an altitude of 1,500 feet and airspeed of 80 miles per hour, Irvin jumped from its turret cockpit wearing a prototype Model A chute. He pulled the ripcord, the parachute opened in one and two-fifth seconds, and he became the first man to make a free-fall parachute jump from an aircraft.

The new parachute was the first step on the way to all modern personnel parachutes—emergency, military, and sporting. From this basic design came the seat pack, chest or reserve chutes, backpacks, and any other parachute that can be attached to a harness.

In October 1922, Lieutenant Harold Harris, U.S. Army, was dramatically saved from death by using a manually-operated parachute when his aircraft failed. By March 1924, it became mandatory for all Army and Navy aircrew to wear the standard back-type parachute while in flight. A sign in one of the parachute lofts read, "Don't forget your parachute. If you need it and you haven't got it, you'll never need it again."

With the requirement for all Navy aviators to wear parachutes, the necessity for trained personnel to pack and maintain these parachutes became apparent. In June 1922, the Bureau of Aeronautics requested volunteers from among the petty officers attached to the various naval air stations to take a course of instruction in parachutes at the Army School at Chanute Field, Rantoul, Illinois. Thirteen chief petty officers were selected from throughout the Navy. They completed the course of instruction and returned to their duty stations. Three of them were selected for further training at McCook Field, Dayton, Ohio, at that time the Army Equipment Experimental Depot. The three chief petty officers received advanced training in parachutes. In August 1923, Chief Alva Starr and Chief Lyman Ford, two of the three, were ordered to Lakehurst, New Jersey, to set up a training course on parachutes. Although the course was established, the PR rate was not established until 1942. In

September 1924, class No. 1 was convened at the Parachute Material School at Lakehurst to teach parachute rigging.

Although his name is now lost to history, one of the farsighted founders of the PR school decided on a novel means to help combat the airmen's reluctance to "hit the silk." He reasoned that if it became known that the men who packed and repaired the parachutes had enough confidence in their ability and equipment to make a deliberate, premeditated jump, the aviator might be more willing to take a chance on his parachute than to crash in his airplane. In the beginning, graduate trainees jumped from the outer wing tips of a biplane flying high above the naval air station at Lakehurst. Later, the students "let go" from short rope ladders suspended from the sides of the old gondola airships (blimps), and later still, from training and patrol type lighter-than-air ships. Since the beginning of the PR school in 1924, there have been over 72,000 parachute jumps made at Lakehurst, New Jersey.

With the coming of the jet age, the emergency use of parachutes has become a highly technical sequence; that is, events in time order. Today's emergency sequence for ejecting from a disabled aircraft starts with the aircrewman making a decision to leave the aircraft. After making that decision everything is done automatically, as you will see in the ejection sequence for the A-6 aircraft, shown in figure 1-1. This is only one of

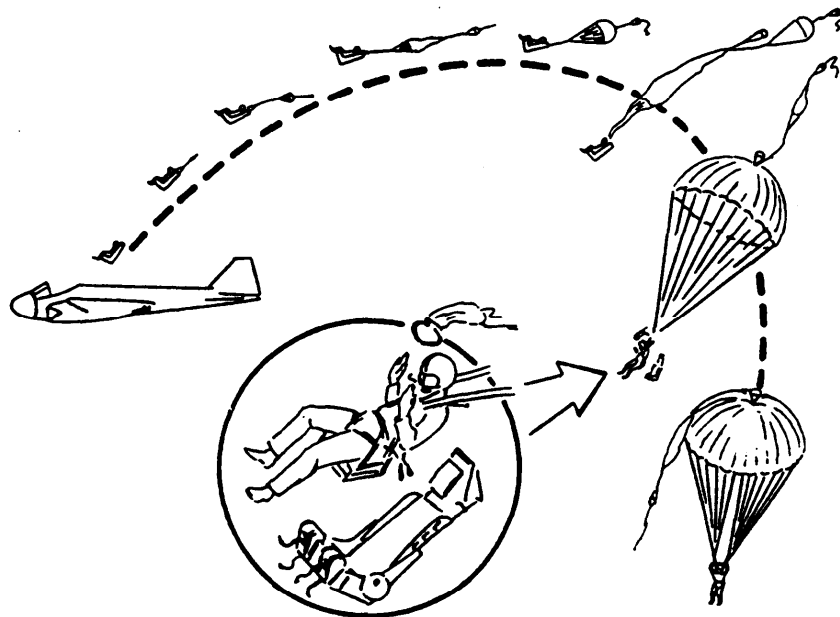
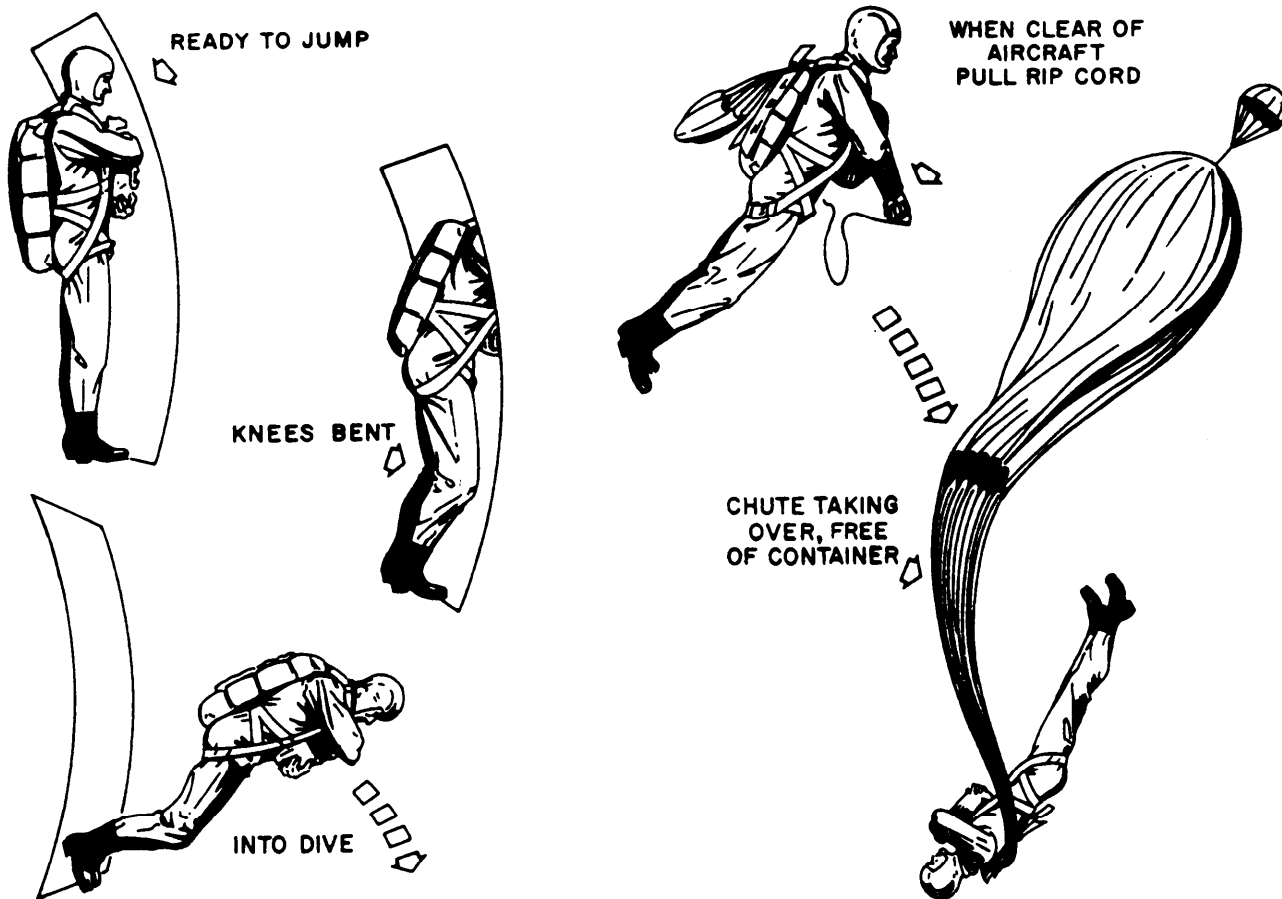

Figure 1-1.—Ejection sequence.

219.267



239.110

Figure 1-2.—Aircraft egress, pilot chute deployed, and main canopy free of container.

several types of ejection systems used in modern naval aircraft. For example, the ejection sequence of the Mk GRU-7 is as follows:

1. Initial ejection.
2. Drogue gun fires.
3. Controller drogue deploys.
4. Stabilizer drogue deploys.
5. Main parachute deploys and a normal parachute descent is made.

From the experimental devices of the early Chinese through the seat ejection systems of today, you can view the evolution of the parachute. If you consider this development as a window through which you can see solutions to the escape problems of the fliers of the space shuttle or other advanced craft, then this history is just the end of the beginning.

A parachute appears somewhat similar to a giant umbrella. By offering a large air-resisting or drag surface, the parachute, when opened, provides the deceleration necessary to allow for

the safe descent of an aircrewman. In each parachute jump a sequence of events, shown in figure 1-2, takes place. After the parachutist clears the aircraft, he pulls the ripcord. The ripcord pins are removed from the locking cones, permitting the grommets to separate from the locking cones. The container spring opening bands pull the side and end flaps apart allowing the pilot chute to spring beyond the negative pressure area immediately above the falling body. This results in its getting a better "bite" on the surrounding air, thus speeding the opening of the canopy.

The aircrewman falling away from the pilot parachute causes the main canopy to be pulled from the container assembly, followed by the suspension lines. The canopy begins to fill with air during this operation.

The ties on the risers break as the load is applied. The lift webs are then pulled from the container while the canopy fully opens; at this point the parachutist receives the opening shock as

the parachute fills with air. The aircrewman then hangs or sits suspended in the harness during the descent.

There are many different types of parachutes used in today's naval aircraft. To really understand the operating principles of a parachute, you should first know the basic design and construction of a parachute and its components.

COMPONENTS OF PARACHUTES

The design and construction of a parachute and its components are based on the old idea that a chain is only as strong as its weakest link. Every

component, or link from the jumper to the canopy must carry its share of the maximum load that is applied during the opening shock.

The five major parts of a standard service parachute, starting at the top and working down, are the pilot chute, main canopy, suspension lines, harness, and pack. These five major parts are shown in figure 1-3.

PILOT CHUTE

The pilot chute has the job of anchoring itself in the airstream, then pulling the remaining packed components out of the parachute pack. The order of deployment for most parachute

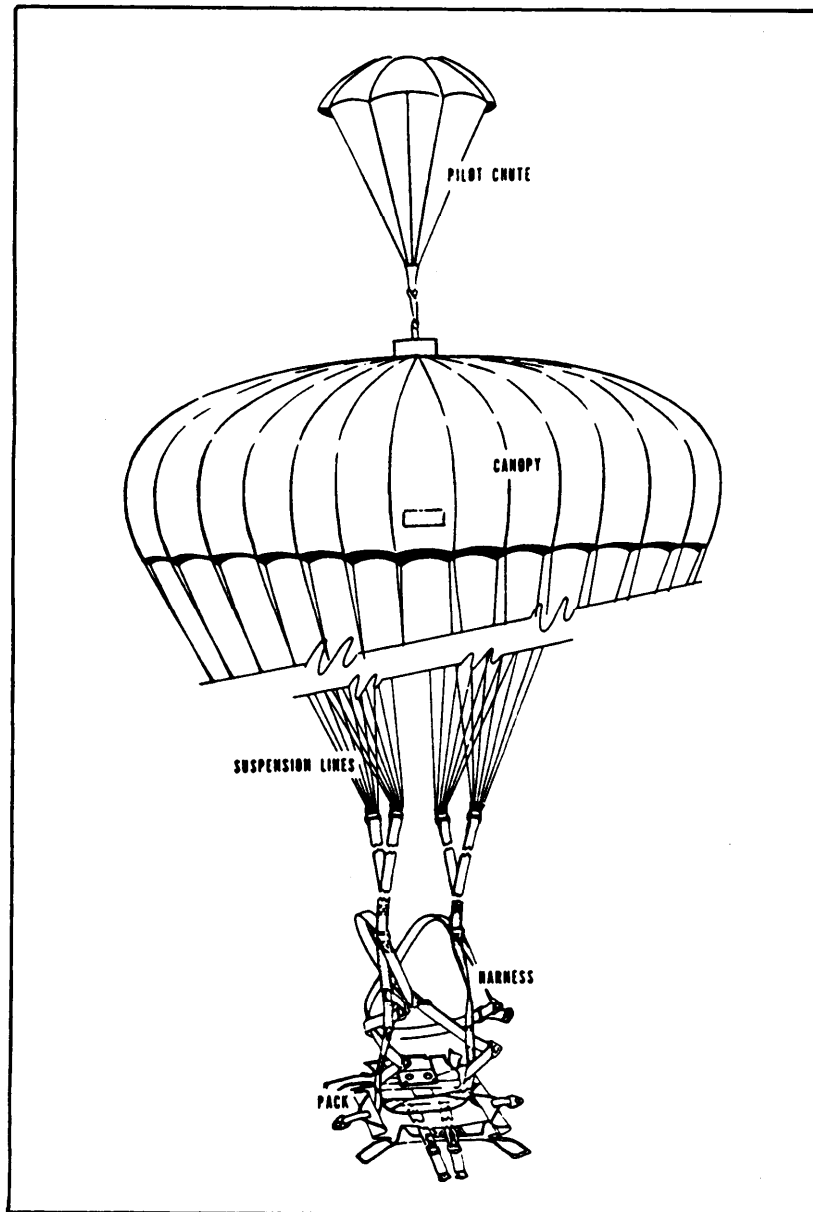

Figure 1-3.—The five major parts of a parachute.

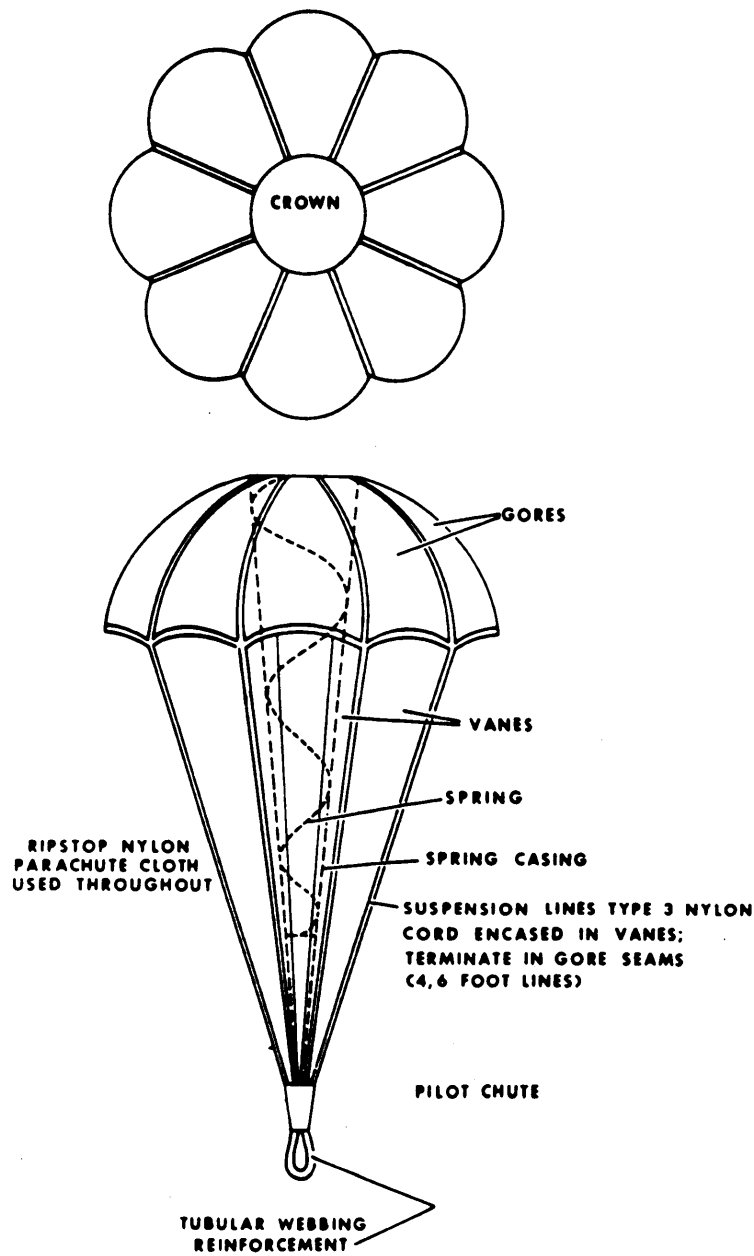

Figure 1-4.—Pilot chute.

239.121

assemblies is the pilot chute, the canopy, the suspension lines, and the risers. A typical pilot chute is shown in figure 1-4.

CANOPIES

Five sizes of canopies are used in naval aviation. They are the 35-foot, 28-foot, 26-foot, 24-foot, and 17-foot sizes. The 28-foot canopy is the size dealt with in this chapter and is most

commonly described as a polygon, having 28 sides, and a diameter of 28 feet plus or minus 1 inch. The 28-foot canopy contains approximately 796 square feet of nylon cloth, plus 2,400 yards of nylon thread. The sewing on a parachute varies from 8 to 10 stitches per inch. The cloth that is used in the construction of a parachute canopy is high-tensile strength, 1.1 ounce ripstop nylon. Ripstop nylon cloth must meet the following minimum requirements: tensile strength—42

pounds per square inch; tear strength —5 pounds; air permeability —80 to 100 cubic feet per minute. Tensile strength is the greatest stress cloth can withstand along its length without rupturing, expressed as the number of pounds per square inch. Tear strength is the average force, expressed in pounds, required to continue a tear across either the filling or the warp of the cloth. Air permeability is the measured amount, in cubic

feet, of the flow of air through a square foot of cloth in 1 minute under a specific pressure.

The suspension lines are sewn into the canopy. These lines run continuously from the connector link on one side, through the canopy, and to the connector link on the other side (fig. 1-5). The material between any two suspension lines is called a gore. There are 28 gores in a 28-foot canopy. Each gore is composed of four sections identified

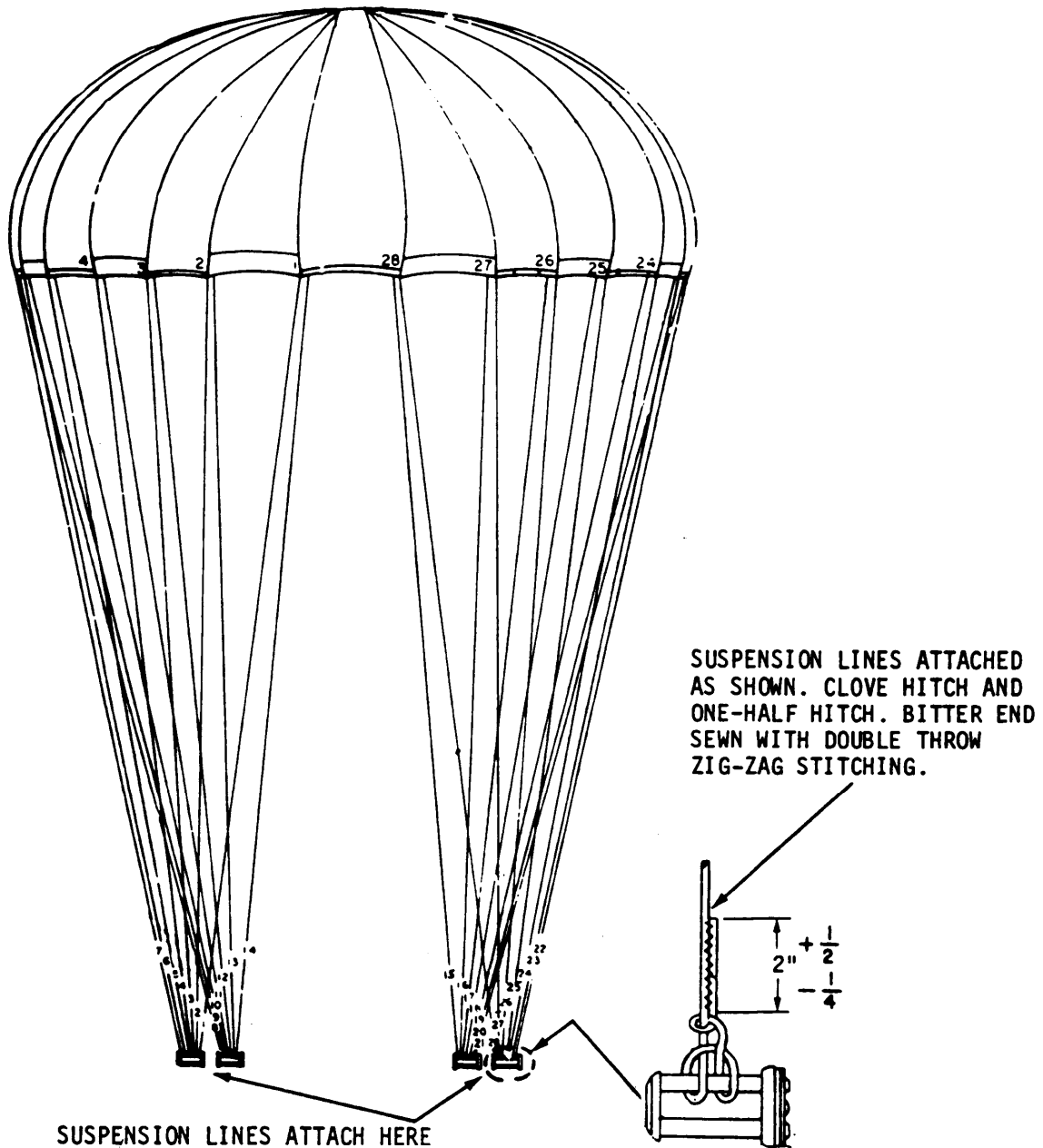
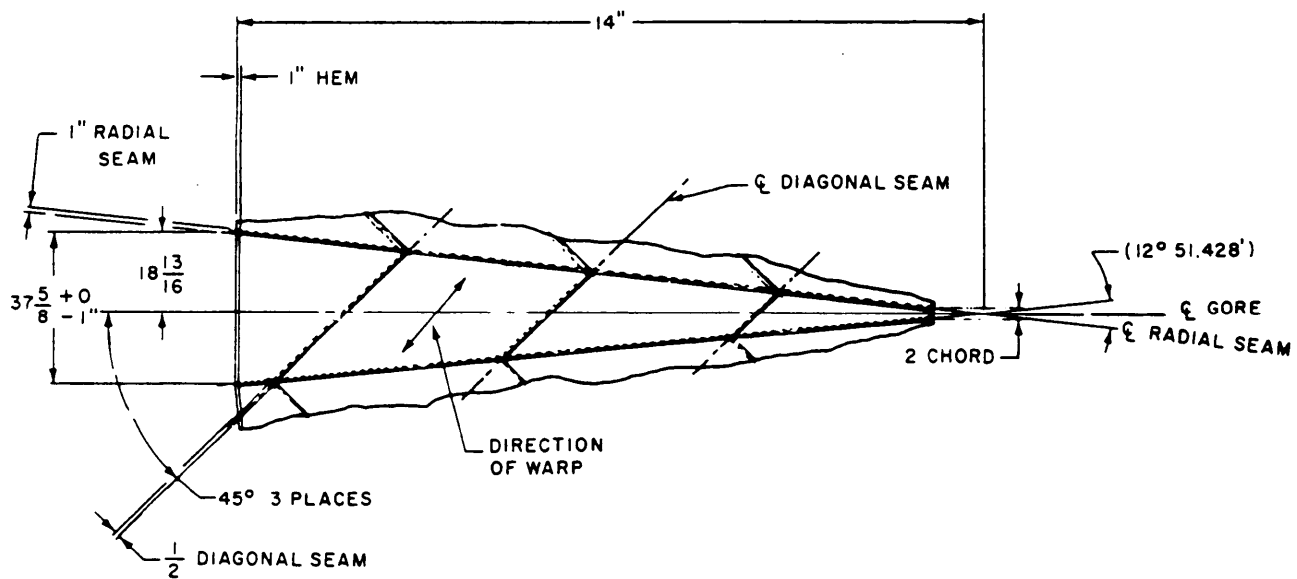

Figure 1-5.—Suspension lines on 28-foot canopy.

239.463



239.123.1

Figure 1-6.-Close-up view of a gore.

by the letters A, B, C, and D (fig. 1-6), starting with the bottom section. Figure 1-7 is a flat view of the entire canopy, and the note in the figure shows the relationship of the gore in figure 1-6 to the rest of the canopy.

Most woven cloth has two types of threads—warp and filling. These two types are identified by their relationship to the selvage edge. A selvage edge is a finished edge on two sides of a piece of fabric to prevent raveling. This finished edge sometimes has a narrow border of different threads or sometimes it may have a different weave. Warp thread runs parallel to the selvage edge of cloth and runs lengthwise down a roll of fabric. Filling thread runs perpendicular to the selvage edge or crosswise across the width of the cloth.

The sections used in a parachute canopy are cut at a 45-degree angle to the centerline of the gore. This is called a bias construction and provides the maximum strength and elasticity. The radial and diagonal seams are double lapped for security. The suspension lines are enclosed in the channel produced by stitching the radial seams. Figure 1-7 shows a flat view of this bias construction of the 28-gore canopy. Stenciled on the top center gore (section A of gore 28) in letters one-half inch high and about 12 inches from the bottom of the canopy are the NAVAIRFAC order number, date of manufacture, serial number, and the manufacturer's mark or trademark. Stenciled

on the diametrically opposite gore (section A of gore 14) is the date of manufacture and serial number.

If you should have to add markings to the canopy, the marking fluid you use should be in accordance with Specification MIL-I-6903A, Amendment No. 1.

Note the vent pictured in figure 1-8. This vent acts as a relief valve and relieves the high internal pressure within the parachute at the instant of opening. Without this vent, an opening at high speed could result in a dangerous rupture of the canopy. The skirt (not shown) and vent hems are reinforced with 1-inch tubular nylon webbing with a tensile strength (T/S) of 4,000 pounds, to aid in preventing tears from completely separating the canopy.

All machine stitching, except zigzag, should conform to Type 301, Federal Standard 751, and should be not less than 8 nor more than 10 stitches per inch. Ends of all tape, webbing, and lines must be seared to prevent fraying. No waxes should be used. For sewing diagonal seams, either size B or E nylon thread may be used. Use size E thread for all other seams, zigzag stitching, and repairs.

Removable connector links provide a quick attachment for the canopy and suspension lines to the lift webs.

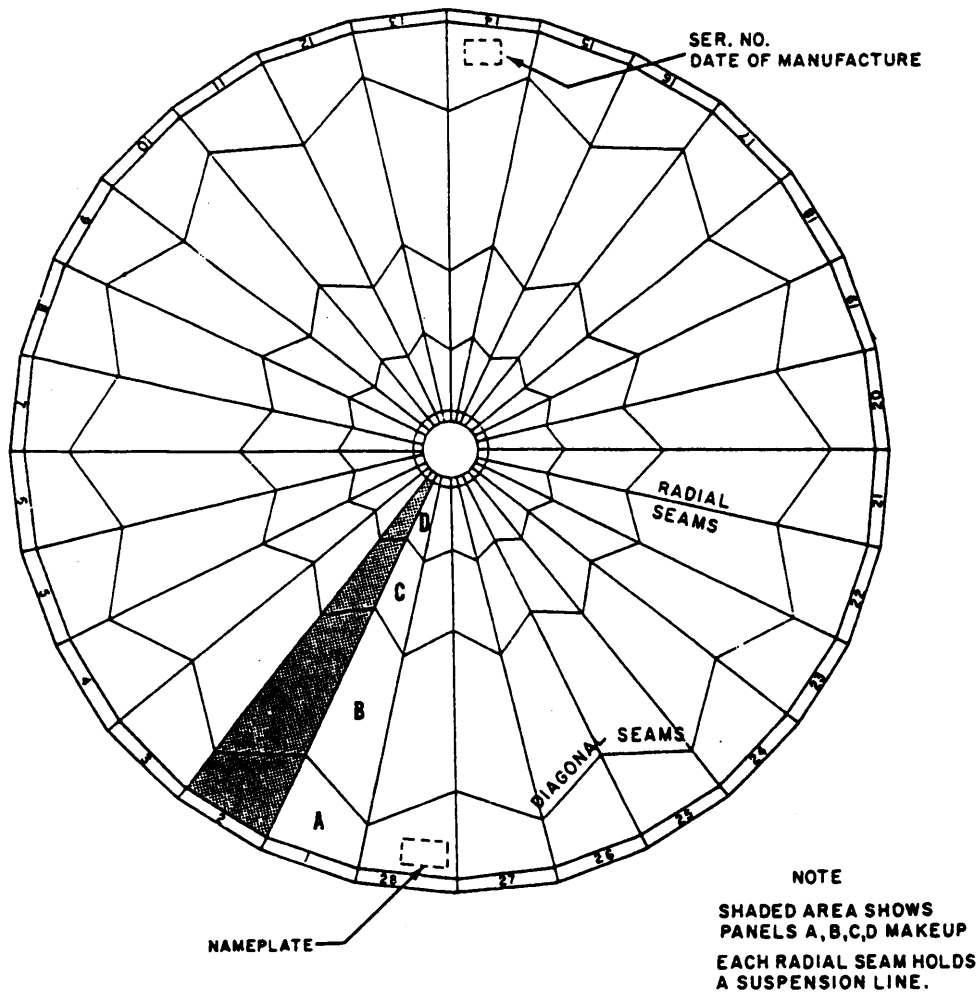

239.464

Figure 1-7.—Flat view showing bias construction on a 28-foot canopy.

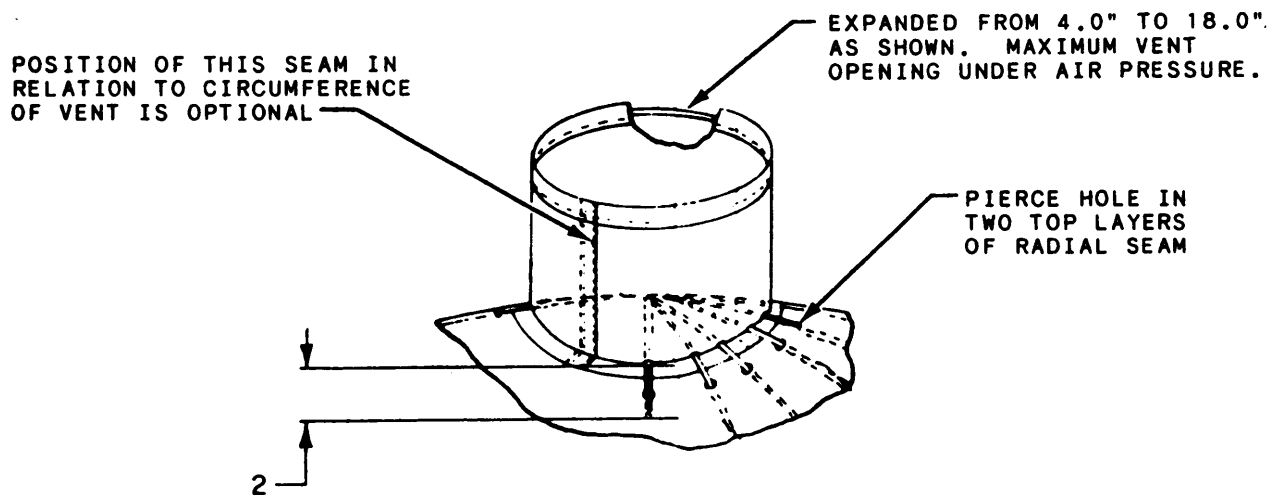

239.465

Figure 1-8.—Vent.

NOTE: To determine the service life of a parachute component, refer to the Maintenance Requirement Cards, NAVAIR 13-600-4-6-3.

SUSPENSION LINES

The suspension lines form a net or skeleton for the canopy and absorb much of the shock load. Therefore, when being assembled, they must be placed under a 20-pound tension, marked, and cut as a group to assure equal distribution of the shock load. The 28 suspension lines counted at the links are actually 14 lines, 75 feet 4 inches in length. These lines run continuously from link to link; that is, each line is secured to a connector link on one side of the canopy, runs up and over the canopy, and down to a link on the opposite side.

Type III nylon suspension line (with a minimum tensile strength of 550 pounds) is used on all main canopies and vane-type pilot chutes. This line consists of a loosely woven outer covering called a sleeve, and several strong inner cords called the core. This core provides the greater portion of the strength of the suspension line.

The suspension lines are attached to the connector links by tying a clove hitch, then a half-hitch, and completing the attachment with 2 ($\pm 1/2$ or $- 1/4$) inches of zigzag stitching. These lines are attached to the lift webs with removable connector links. One of the four removable connector links is shown in figure 1-9. See the four links (the ends of the suspension lines without the lift webs) in figure 1-5.

To prevent the canopy on the 28-foot parachute from slipping along the suspension lines, each line is anchored by zigzag stitching at several points to the radial seams through which it passes. One-half inch of slack is allowed in the vicinity of the skirt between the zigzag sewing points to relieve the strain during opening shock.

PARACHUTE CONTAINERS

The parachute container is designed to house and protect the pilot chute, main canopy, and suspension lines. There are as many different styles of containers as there are parachutes. They all have the same basic opening procedures. There are four flaps: top, bottom, left, and right. These flaps are held closed by two or four ripcord pins inserted through locking cones. To open the parachute container, the ripcord pins must be removed either manually or automatically. This allows the flaps to open and the pilot chute to spring from the pack. The pilot chute then pulls the canopy out.

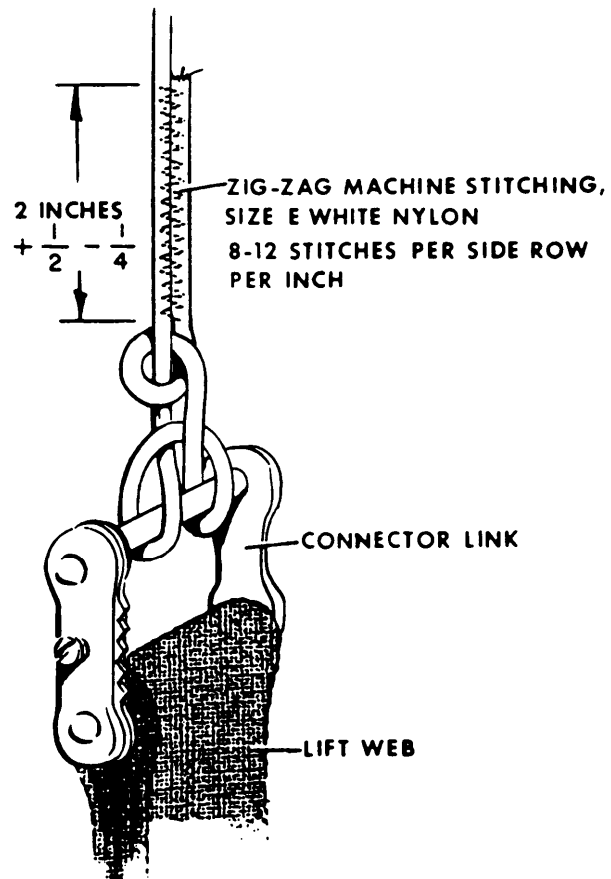

239.126

Figure 1-9.—Method of attaching suspension lines at the link.

PARACHUTE HARNESS

The harness is the part of the parachute that holds the parachute to the wearer. It is designed to absorb the largest part of the opening shock, with chest, leg, and back straps added to prevent the jumper from falling free from the chute on the way down. Personnel parachute harnesses are made of 1 3/4-inch-wide nylon webbing, which has a tensile strength from 6,000 to 8,700 pounds.

The Navy uses two types of harnesses. The first is the quick-fit harness. It is made in three configurations: seat-type, back-type, and chest-type. The other type of harness is the integrated torso harness. It combines the harness, lap belt, and shoulder harness into one integrated garment. This harness improves the individual's comfort and mobility; it is more secure and is easier to put on and take off. It also reduces the number of exposed straps and overall bulk and weight.

RIPCORDS

The ripcord is a manual releasing device used to allow the container to open. It consists of locking pins securely attached to a length of 3/32-inch diameter corrosion-resistant steel cable. The ripcord handles are made of steel tubing in the shape of a cloverleaf or a trapezoid, and they are attached by passing the cable through a small hole drilled in the grip and then swaging a retaining ball or clamping a small sleeve onto the loose end of the cable. The pins are swaged in place and tested to withstand a pull of 300 pounds.

HARNESS HARDWARE

Parachute harness fittings (hardware) are small metal devices usually made of cadmium or chrome-plated steel. They are designed to join the parachute and harness and to afford easy and rapid adjustment of the harness to the wearer.

The many types of parachute harness fittings include adapters, snaps, D-rings, V-rings, connector links, and Koch release adapters. Some of the more common types of these fittings and their tensile strengths are illustrated in figure 1-10.

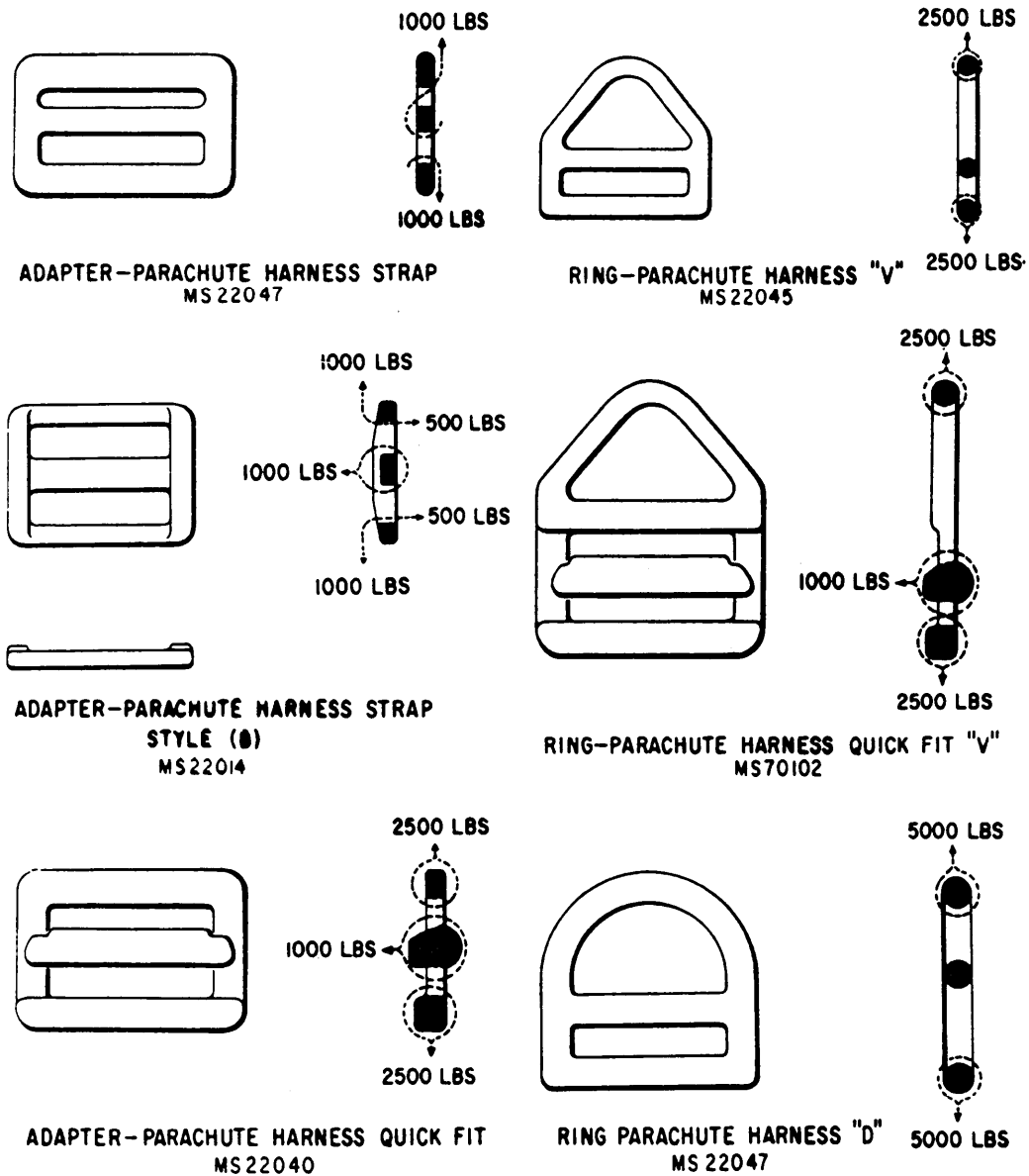
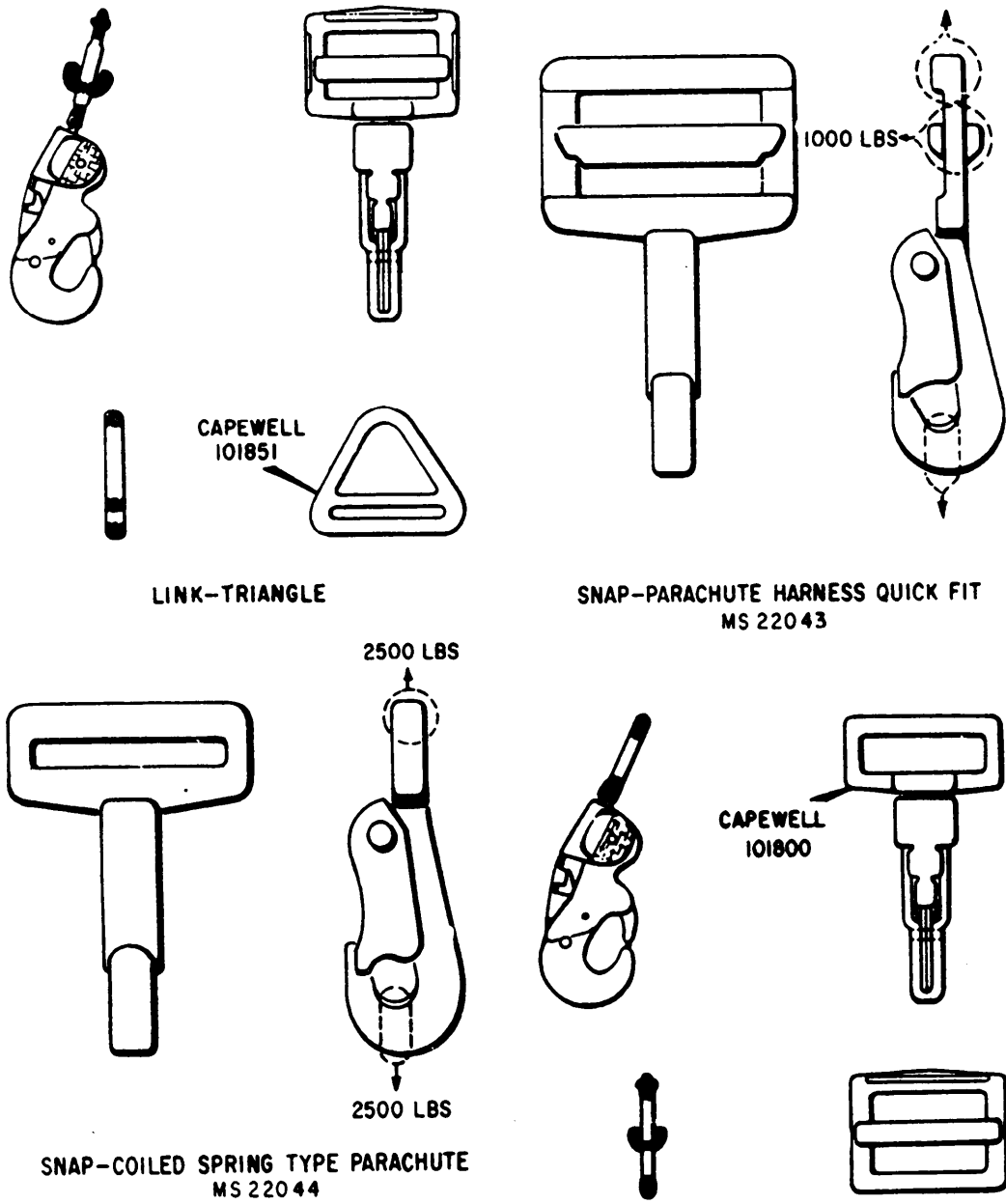

Figure 1-10.—Harness hardware (page 1).

239.136



LINK-TRIANGLE

SNAP-PARACHUTE HARNESS QUICK FIT
MS 22043

SNAP-COILED SPRING TYPE PARACHUTE
MS 22044

239.137

Figure 1-10.—Harness hardware (page 2).

ADAPTERS

Two types of adapters are used with a regular quick-fit type harness. They are the regular harness adapter and the friction adapter. The harness adjuster adapter is used to adjust the harness to the wearer, and the friction quick-fit adapter has a grip slide bar, which allows the wearer to make quick adjustments to the harness.

SNAPS

There are several types of snaps used with parachutes. They are the plain harness snap, the quick-fit snap, and the quick-connector snap. The harness snap is a plain hook-shaped, spring-actuated guard, which snaps over a V-ring to secure two parts of the harness together. The quick-fit snap is similar except that it has a grip slide bar. The quick-connector snap is similar to

the harness snap and is used as a means to quickly attach the Navy chest-type parachute to the two D-rings on the Navy chest-type harness.

CONNECTOR LINKS

Connector links are fittings designed to join the parachute to the harness. The suspension lines are attached to one side and the harness to the other connector links.

KOCH RELEASE ADAPTERS

Integrated torso suit harnesses are equipped with four Koch release adapters, which attach to the fittings on the lap belts and risers of the integrated parachute assembly. Release fitting adapters are manufactured in two parts—male and female.

The male portion of the adapter is attached to the torso suit harness, while the female portion is attached to the riser assembly of the parachute. Figure 1-11 shows the Koch parachute release adapters.

NOTE: Aircrew Systems Change 446 incorporates the “parachute harness sensing release unit,” commonly referred to as SEAWARS. SEAWARS is designed to automatically release the parachute risers upon immersion in seawater.

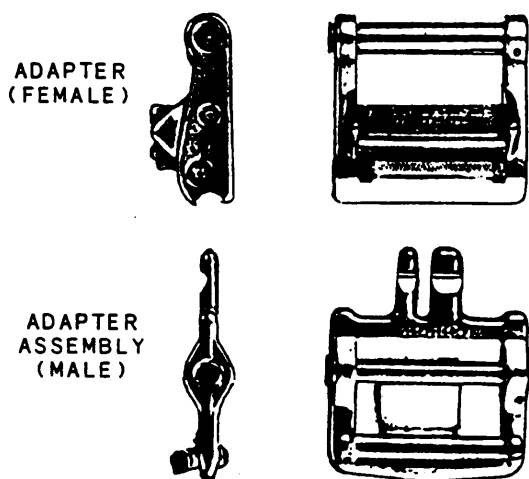

239.138

Figure 1-11.—Koch release adapters.

TRANSPORTING PARACHUTES

When issuing parachutes you may need to give some instructions to the aircrewmembers on proper ways to carry and handle them. The most effective way to explain the proper handling of packed parachutes is to list a series of DO's and DON'T's.

1. DO NOT pick up a parachute by its risers or ripcord. Lift web tackings break relatively easily, and when they do, the suspension lines are almost certain to become disarranged.
2. DO NOT allow a parachute to come in contact with light fixtures or heat sources. Heat tends to decompose the fabric.
3. DO take EVERY precaution to prevent soiling or contaminating parachute assemblies.
4. DO NOT stack parachute assemblies on top of each other or on the floor, unless they are in suitable shipping containers.
5. DO NOT leave a parachute where heavy objects can be dropped or placed on it. Permitting a parachute to be carried in a cargo net along with squadron cruise boxes or similar gear is an example of poor handling techniques.
6. DO use utmost CAUTION when handling parachute assemblies with installed cartridge-activated devices.
7. DO NOT tack or tie a container with the parachute in the packed condition.

8. DO clean thoroughly vehicles used to transport parachute assemblies. DO check for contamination and provide with suitable covers during inclement weather.

SHIPPING CONTAINERS

Parachutes are shipped and/or stored in sealed shipping containers of either cardboard or metal construction and of suitable size. The containers are designed for reuse, and they must be opened and closed with care.

When you are using the container to return parachutes to supply or to transfer the assembly to another activity, ensure that the old tags and labels on the container are removed or marked out. Ensure that the proper tags and labels are attached and properly filled out on the transferring container. Tags and labels are shown in figure 1-12.

STORING

To place a parachute assembly into temporary storage, proceed as follows:

NOTE: This procedure is for parachute assemblies that are in a ready-for-issue (RFI) status only.

1. Inspect the parachute assembly, ensuring that it is in an RFI status. Check the nameplate information with the recorded information on the parachute history card. Fill out an Aircraft Equipment Condition Tag, indicating the assembly name, serial number, and part number.
2. Remove and disarm the automatic actuator. (This is an explosive device used to automatically pull the ripcord on certain parachutes.)
3. Remove cartridges from all other cartridge-actuated devices (these are other explosive devices used to assist in opening certain types of parachute canopies). Store the cartridges from explosive devices in accordance with existing instructions.
4. Release all snap fasteners, open all slide fasteners, and remove one end of each of the parachute container spring opening bands.
5. Chain the parachute suspension lines.
6. Remove the manual ripcord cable assembly and place it in a small paper or plastic bag.
7. Examine the shipping container for condition. Remove or mark out all old tags or labels on the container.
8. Place the ripcord assembly in a side pocket of the parachute bag or at the bottom of the container. Spread one-eighth pound of naphthalene flakes on top of the parachute container. Insert the suspension lines loosely and fold in the canopy; then sprinkle one-fourth pound of naphthalene flakes into the canopy fold. Lay the pilot parachute into the shipping container uncompressed.
9. Close the shipping container; if a cardboard box is used, tape the flaps closed.
10. Place the parachute into storage according to local requirements.

PERSONNEL PARACHUTE INSPECTIONS

As a PR you have one of the most important jobs in naval aviation. The type of equipment you will be working with is lifesaving equipment. Unlike the other components that make up the naval aircraft, the parachute has no backup system. If all other parts fail, the parachute must function to prevent serious injury or death to the aircrewman.

Parachutes are primarily designed to allow pilots and aircrewmen to escape from disabled aircraft. The nature of this lifesaving system leaves no margin for error in the work of the PR. Parachute inspections must be carefully conducted, ensuring security, rapid positive functioning, airworthiness, and comfort of the entire assembly.

Procedures for working with parachutes are different from other types of work because whenever a critical operation is performed, the rigger's work must be inspected and his performance verified and recorded by a designated inspector before work continues. Continuing with a procedure without obtaining the required inspection is prohibited. Although this constant interruption of work may seem inefficient, you must appreciate how important it is to the parachute user that every step is done exactly right.

REASONS FOR INSPECTING PARACHUTES

Depending on its use, a parachute is exposed to a large number of potentially destructive forces and agents. A parachute consists of many parts and is a complex and sometimes fragile assembly, so there are many chances for something to go wrong. Once a parachute has been inspected, repacked, and placed in service, it is moved around, sat on, leaned against, and in many ways subjected to forces that can cause chafe and wear. When installed in an aircraft or being worn, the parachute may be contaminated by a number of potentially harmful fluids such as perspiration, lubricants and hydraulic fluids, chemicals, and salt water. Dampness can also get into the components from humid conditions.

Aside from inspecting for damage, new parachutes are inspected before being placed in service because it is possible for a mistake to be made when many persons are involved in a manufacturing process. A parachute may also

AIRCRAFT EQUIPMENT CONDITION TAG	
NUMBER 2650 (REV. 4-64)	
PURCHASING ACTIVITY	
OFFICE NO.	
QTY. PART OR NO.	SERIAL NO.
SIGNATURE	
PACKAGED/PRESERVED	
DATE	QTY. METHOD
REWORKED OVERHAUL (Date) <input type="checkbox"/>	REVISED TO (Date) <input type="checkbox"/>
CHANGED TO (Date) <input type="checkbox"/>	DELETED <input type="checkbox"/>
AUTHORITY FOR CHANGE	
INSPECTOR AND DATE	
RFI	
Affix appropriate shipping label (NUMBER 2650 series) in this space when required	

READY FOR ISSUE TAG (FRONT)
(COLOR MANILA)

MODIFICATIONS INCORPORATED	
NUMBER 2650 (REV. 4-64) (BACK)	

READY FOR ISSUE TAG (BACK)
(COLOR MANILA)

OFFICE NO.	SHIP TO
SIGNATURE	
QTY. PART OR NO.	DATE
PURCHASING ACTIVITY	SIGNATURE AND DATE
NON-RFI	
AIRCRAFT EQUIPMENT NON-RFI CONDITION TAG/LABEL, NAVJEP'S FORM 4035/1D(4-64) S/P 0100-003-0000	

NON READY FOR ISSUE TAG
(COLOR GREEN)

REQUIRES SCREENING	
READY FOR RETURN	
SHIP TO (Address)	
DATE	
SIGNATURE	
NUMBER 2650	4-64000-1 QPO

SCREENING LABEL
(COLOR BLUE)

OFFICE NO.	SHIP TO
SIGNATURE	
QTY. PART OR NO.	DATE
PURCHASING ACTIVITY	SIGNATURE AND DATE
NON-RFI	
AIRCRAFT EQUIPMENT NON-RFI CONDITION TAG/LABEL, NAVJEP'S FORM 4035/1D(4-64)	

NON READY FOR ISSUE LABEL
(COLOR WHITE)

Figure 1-12.—Shipping tags and labels.

239.116

require changes and modifications. These are issued by the Aircrew System Bulletins, Aircrew Systems Changes, and updated material entered in the *Emergency Personnel and Drogue Parachute Systems Manual*, NAVAIR 13-1-6.2.

As you can see, many things can happen to a parachute in service. Inspection schedules based on experience are established to ensure that damage is detected before it becomes serious. You have the responsibility of following these

schedules and for properly doing the required inspections.

INSPECTION SCHEDULES

The frequency and nature of parachute inspections depends on the use of the parachute. Those used regularly for jumping, such as parachutes assigned to SEAL teams, are inspected and repacked after each use; these and others are on a different schedule than those intended for emergency use. Our discussion focuses on emergency parachutes to emphasize that although they are rarely used, they may be damaged in handling or exposed to hazards in their environment.

Emergency parachutes are assigned to operating units. They may be part of an aircraft inventory or they maybe assigned to a ready issue room. To some extent, the frequency of their inspection depends on the type of aircraft to which they are assigned. Those assigned to attack or fighter aircraft are inspected more frequently than those on the larger patrol, cargo, or other planes where they are not sat upon or otherwise subjected to as many hazards.

Major inspections of emergency parachutes are routine when the parachute is first put into service, and then later at intervals to coincide with the time the aircraft is down for major maintenance.

Less extensive inspections that do not involve unpacking the parachute are daily, preflight, postflight, and special. These special inspections are done every 7 days, 10 days, or 14 days, depending on the type of aircraft. Of course, if any damage is found or suspected during these inspections, the assembly is sent to an aviation intermediate maintenance depot (AIMD) for thorough inspection, testing, and possible repair.

Several special inspections may also be done. For instance, after a combat mission the parachute assembly is inspected for missile damage from bullets or fragments. After an emergency use the entire parachute is shipped to the Naval Weapons Center, China Lake, California, for a detailed inspection. Other inspections may be ordered if defects are suspected in a group of parachutes or in association with authorized changes and modifications.

PARACHUTE MAINTENANCE

All parachutes are given periodic maintenance inspections under the direction and control of the maintenance control officer. Maintenance is to be thorough at all times. No instance of careless treatment or neglect of parachute equipment is to be allowed to pass unnoticed. The vital function of this equipment must be uppermost in the minds of all personnel concerned.

SPECIFICATIONS

Parachute maintenance and inspection procedures are performed according to the guidelines set forth in the *Emergency Personnel and Drogue Parachute Systems Manual*, NAVAIR 13-1-6.2, and the *Maintenance Requirements Cards*, NAVAIR 13-600-4-6-3. These manuals are continually updated, and when using them, as in using any publication, you must first make sure that the current changes are included. The manuals will list all of the proper steps, procedures, and points to inspect. They also give you information about proper specifications, technical data, and are used to ensure that all steps are followed, all details are inspected, and that all quality control items are checked at the proper time by a quality assurance inspector (QA). Using these manuals is mandatory and ensures that you are following the current and approved procedures.

Whenever a question on the construction of parachute equipment comes up, you should obtain and study the drawing that applies. Repairs that are difficult should be compared to the drawing to ensure that the finished product is the same as the one in the drawing. The drawing number or reference number of a particular piece of parachute equipment can be found in the applicable work package in the *Emergency Personnel and Drogue Parachute Systems Manual*, NAVAIR 13-1-6.2.

All parachute maintenance is done by the lowest level activity equipped to satisfactorily perform the work. Mission, time, equipment, trained personnel, and operational needs are the basic considerations involved in determining which level performs the work.

PARACHUTE CONFIGURATION INSPECTION AND HISTORY RECORD (instructions on reverse)									
TYPE PARACHUTE NES-12		PART NUMBER 576AS100-30		SERIAL NUMBER (canopy) 32441		DATE PLACED IN SERVICE 3-82			
AIRCRAFT BUNO/SERIAL 145246		CUSTODIAN 3M ORG CODE PEE		SCHEDULED REMOVAL DATE 4004		DATE REMOVED 3362			
CARTRIDGES AND CARTRIDGE ACTUATED DEVICE									
DEVICE OR CARTRIDGE NOMENCLATURE	PART NUMBER	CARTRIDGE DODIC	DELAY TIME	LOT NUMBER	CAN OPEN/INST DATE	EXPIRATION DATE	LOCAL USE/SERNO		
AUTOMATIC OPENING DEVICE	711-07022-3A	N/A	N/A	N/A	MFGD 3-82	N/A	14386		
AUTOMATIC OPENING DEVICE CARTRIDGE	MK4M002	M2B2	0.75	IM-81-K002-001	COD 3-82	3-85	1591		
SPREADING GUN	SK86-0054-12	N/A	N/A	N/A	OVHL 9-82	9-92	8945		
SPREADING GUN CARTRIDGE	CCU-33/A	MF78	0.0	02-SAEC-0382	COD 12-82	12-85	136		
L/H PHSRU CARTRIDGE	851AS275	MW19	0.0	5-82	COD 12-82	12-86	112		
R/H PHSRU CARTRIDGE	851AS275	MW19	0.0	5-82	COD 12-82	12-86	116		
BATTERY	B52AS102	N/A	N/A	CAX84B001-004	8-84	8-87			
BATTERY	B52AS102	N/A	N/A	CAX84B001-004	8-84	8-87			
TECHNICAL DIRECTIVES				MISCELLANEOUS HISTORY					
DIRECTIVE			DIRECTIVE			DAMAGE CHART ATTACHED		RIPCORD PIN PULL FORCE CHECK	
TYPE	NUMBER	STATUS	TYPE	NUMBER	STATUS	<input type="checkbox"/> YES <input checked="" type="checkbox"/> NO	DISASSEMBLY	REASSEMBLY	
66	438	C				BSG FIRING PIN CHECK	READING	READING	
						29 LB	25 LB	25 LB	
66	446	C				DATE OF LAST COMPLETE INSPECTION AND REPACK	QA INITIALS	QA INITIALS	
						3159	L.H.B.	L.H.B.	
						INSPECTION	SLMIP INSPECTION (QA initials) L.H.B.		
						A EPC	B N/A		
						ALTITUDE CHECK	FOR LOCAL USE		
						1 13400 FT			
						2 13200 FT			
						3 13300 FT			
CONFIGURATION VERIFICATION (List each item that has service life)									
NOMENCLATURE	PART NUMBER	CONTRACT NO.	DATES			REMARKS			
			MFG	SERV	EXP				
PILOT CHUTE	60A125E16-1	N4160B-80-C-0377	9-80	3-81	3-88				
BRIDLE ASSY	510AS106-1	N00383-75-C-0131	9-77	4-79	9-89				
CANOPY	107AS106-22	N00383-81-C-4528	1-82	3-82	3-87				
CROSS-CONNECTORS	677AS100-2	N60530-82-C-0311	5-83	12-83	12-95				
RISERS	510AS136-17	N00383-77-C-0888	12-77	10-78	10-96				
CONTAINER	510AS101-97	N00383-82-C-2790	9-82	12-82	12-94				
EPC	510AS108-1	N00383-81-C-4577	2-82	12-82	12-89				
EPC BAG	699AS101-1	N00383-80-C-2160	8-80	12-83	12-85				
L/H PHSRU EPA	852AS101	N60530-83-C-0043	12-83	12-83	12-89	S/N 306			
R/H PHSRU EPA	852AS101	N60530-83-C-0043	12-83	12-83	12-89	S/N 123			
PACKED BY (Full name) PR-2 Kevin J. Taylor		INSPECTED BY (Full name) PR-1 L.H. Ballwin		3M ORG CODE P9C		DATE 3363			

Figure 1-14.—Parachute configuration inspection and history record.

service life (fig. 1-14). The form is a two-part NCR form. The hardback copy is to be filed in the aircraft logbook for the aircraft in which the parachute is installed. All original (flimsy) copies of the history record are maintained in a permanent file as designated by the cognizant aircraft maintenance officer. A permanent file

of all history records, including the current hardback copy, is maintained as designated by the cognizant aircraft maintenance officer for spare parachute assemblies; upon installation of the spare parachute into an aircraft, the hardback copy is transferred to the appropriate aircraft logbook. Upon transfer of the aircraft or

parachute assembly from one activity to another, all original (flimsy) copies from the permanent file are transferred to the new custodian to provide a complete history of the parachute assembly. This will also initiate the new custodian's permanent file. When a parachute assembly has been involved in an aircraft accident, the history record and the permanent file of original (flimsy) history records are forwarded to the Commander, Naval Weapons Center (Code 64123), China Lake, CA 93555.

Initiation

The IMA placing the parachute assembly into service initiates the Parachute Configuration Inspection and History Record. The IMA initiates a new history record each time the parachute assembly is inducted for repack or maintenance. All required entries must be legibly recorded, using a ball-point pen or typewriter. The Aircraft Buno/Serial Number block maybe annotated in pencil or left blank, to be filled in by the cognizant custodian of the parachute assembly. Entry errors are ruled through a single line and initialed by the quality assurance inspector. The hardback copy from the previous inspection can be destroyed upon acceptance of the newly repacked parachute assembly by the OMA.

The type parachute (NES-12, A/P28S-27), the parachute assembly part number (576AS100-27, MBEU 10030PA-4), the canopy serial number, the date the canopy was placed in service (month and year), the aircraft buno/serial number, the controlling custodian's alphanumeric 3-M organization code, the next scheduled removal date (Julian date), and the actual removed date (Julian date) must be entered at the top of the history record.

Cartridges and Cartridge-Actuated Devices

The parachute in the example uses a cartridge-actuated device, so you must fill out the appropriate columns on the history card. If the parachute does not use the devices listed, you must use the letters N/A (not applicable) in the column(s). Enter the part number, type of cartridge being used, the time delay of the cartridge, lot number, and the expiration date of the cartridge.

Technical Directives

Since you are placing the parachute into service, you must update its history of technical directives with prescribed changes and modifications that were previously incorporated. The codes used to properly fill out this part of the history card can be found in appendix K of OPNAVINST 4790.2 (series). You also need to use NAVAIR 13-1-6.2 to find a listing of all technical directives that apply to this equipment.

Miscellaneous History

If applicable, you should enter the results of the ripcord pin pull force check for both disassembly and assembly. Notice the quality assurance inspector's initials are entered below each recorded measurement. The inspector's initials must also be placed in the space following the Suspension Line Mandatory Inspection Point (SLMIP). If applicable, the automatic parachute ripcord release firing altitude and the results of the spreading gun firing pin pull force check are logged in the proper location. If these checks do not apply, you should enter N/A. You should enter the Julian date of the last complete inspection and repack, if applicable. If you find these actions are not applicable, enter N/A. Indicate whether or not a canopy damage chart is attached by checking the appropriate box.

Configuration Verification (A list of each item that has a service life)

All parachute components other than cartridges and cartridge-actuated devices with assigned service life must be entered in the Configuration Verification Section of the history record. Service life items can be identified by referring to the Illustrated Parts Breakdown Numerical Index of the applicable parachute assembly work package. Enter the nomenclature, part number, contract number, manufactured date (month and year), placed-in-service date, and the expiration date for each component with a service life. Obtain the date of manufacture and contract number from the component label. The placed-in-service date is from the date the shipping container seal is broken. If the service life has been extended for a particular component, enter the issuing authority and the date-time group of the authorizing message in the Remarks column. If the contract number is not known or cannot be determined, enter UNK in the appropriate block.

After the parachute assembly has been repaired, inspected, and repacked, and the packer and inspector are satisfied the parachute assembly is ready for flight, the packer and quality assurance inspector must legibly sign their full names and rates, QA stamp in the inspector block, and enter the date and 3-M organization code of the IMA at the bottom of the history record. The stamp must not obscure the signatures.

Procedures

Upon transfer of the parachute, the current hardback copy and all original (flimsy) copies in the permanent file are forwarded to the new custodian to provide a complete history of the entire service life of the assembly.

When a parachute has been involved in an aircraft accident, the record is forwarded in accordance with OPNAVINST 3750.6.

CANOPY DAMAGE CHART FOR 28-FOOT FLAT CANOPY			
ACTIVITY			DATE
DATE OF MANUFACTURE	CONTRACT NO.	SERIAL NO.	INSPECTOR (PRINT)
INSTRUCTIONS			
1. USE FOLLOWING SYMBOLS TO INDICATE LOCATION AND TYPE OF DAMAGE ON CANOPY DIAGRAM.			
	TEAR, 6— INCHES LONG		SINGLE BROKEN DRAG SURFACE THREAD
	TEAR, "L" SHAPED WITH 3— AND 4— INCH LEGS		WEAVE SEPARATION
	TEAR, "T" SHAPED WITH 4— INCH BASE AND 3— INCH LEG		STAINS / DISCOLORATION
	RUPTURE, 8— INCH DIA AT WIDEST POINT		BROKEN SEAMS STITCHES ALONG 3 INCHES OF SEAM
	BURN MARKS		PULLED OR LOOPED SEAM THREAD
	STRAINED AREA		OTHER DAMAGE: EXPLAIN
	PULLED DRAG SURFACE THREAD		
2. MARK DAMAGE USING SYMBOLS TO SHOW AREA AFFECTED.			
3. AS DAMAGE IS REPAIRED ON EACH GORE, PLACE SYMBOL "OK" ADJACENT TO SKIRT AT END OF EACH GORE.			
4. 28-FOOT DIA CANOPIES HAVE NAMEPLATE ON GORE 28.			
REMARKS _____ _____ _____ _____ _____ _____ _____ _____ _____ _____			
THIS IS A PERMANENT RECORD. DO NOT DISCARD. UPON COMPLETION OF REPAIRS, THIS CHART IS TO BE AFFIXED TO THE PARACHUTE CONFIGURATION, INSPECTION AND HISTORY RECORD. (FRONT)			

62 1 5604

Figure 1-15.—Canopy damage chart for 28-foot diameter canopy (page 1).

When a parachute (canopy) has been retired because its total service life has expired, the record may be destroyed. Subassemblies for which the total service life has not expired may be salvaged for future use. Appropriate service life information is transcribed to an Aircraft Equipment Condition Tag (NAVAIR-2650) and attached to the salvaged items if they are to be reused. **Under no circumstances should a salvaged item be reused if its previous history cannot be firmly established.**

CANOPY DAMAGE CHARTS

Whenever a canopy is inspected and found to need repairs, an appropriate Canopy Damage Chart must be filled out. An example of this chart is shown in figure 1-15. The symbols to be used are shown on one side of the chart. As each defect is repaired, you write the letters "OK" in the section representing the respective gore. If repairs cannot be made locally, the chart goes with the

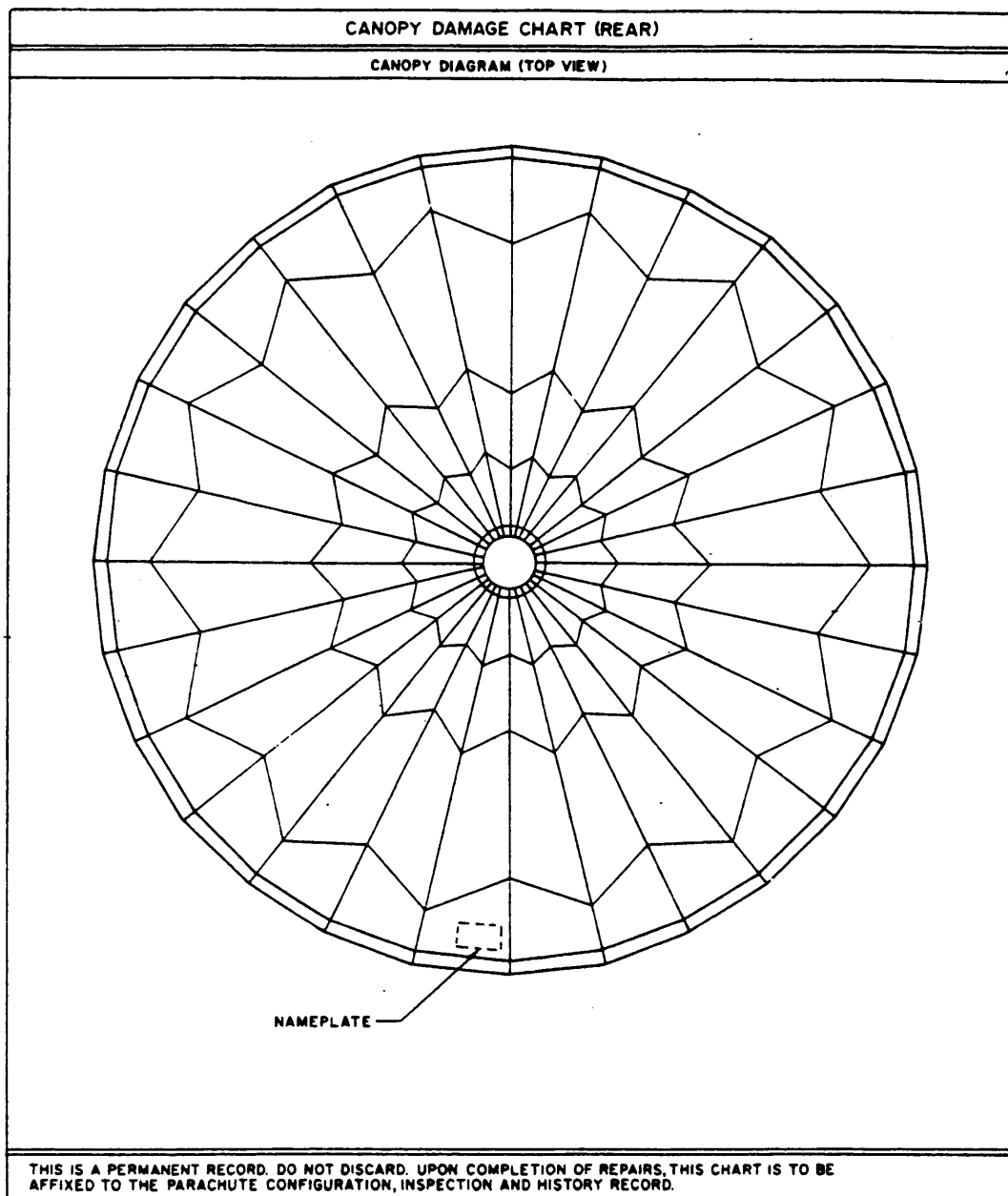

62 1 5605

Figure 1-15.—Canopy damage chart for 28-foot diameter canopy (page 2).

canopy to the next higher level maintenance activity. **This form must not be discarded.** When the repairs are done, the Canopy Damage Chart is attached to the Parachute Configuration, Inspection, and History Record.

NAVAL AVIATION MAINTENANCE PROGRAM FORMS

The following forms used in the Naval Aviation Maintenance Program (NAMP) are applicable to parachute maintenance: VIDS/MAF Form, Support Action Form, and DoD Single Line Requisition System Document. Proper completion of documents is essential to the function of the program. Detailed instructions on their use may be found in the *Naval Aviation Maintenance Program Manual*, OPNAVINST 4790.2 (series).

RECORDING MODIFICATIONS

When a modification is performed on a parachute assembly, you must record the assigned technical directive code and modification code on the Parachute Configuration, Inspection and History Record. Other records must be completed in accordance with OPNAVINST 4790.2 (series).

INSPECTIONS

The various times at which inspections are performed on personnel parachutes are discussed in the following paragraphs.

DAILY INSPECTION

A daily inspection should be performed on all in-service parachute assemblies either installed in aircraft or in ready issue rooms. The inspection may be accomplished by line personnel, or by an issue room custodian who has been checked out by both the AME and PR shops and found qualified. The inspection is performed in accordance with the MRC for the equipment and the requirements detailed in NAVAIR 13-1-6.2 for the aircraft involved. It is done before daily flight operations and is a visual in-place inspection. It is also included in the special (7- or 14-day) inspection.

The packaged parachute is inspected for external evidence of damage. You should be looking for wear or other evidence of physical abuse. The assembly should also be checked for

stains, which may indicate contact with harmful fluids or chemicals. Any stain should be considered harmful until the fluid that made it is identified. Stains or discolorations may also be caused by contact with a hot object. Heat can seriously weaken the synthetic fabrics in parachute assemblies. Another possible source of trouble is exposure to ultraviolet radiation such as sunlight or some types of artificial lighting. Any evidence of damage or suspicious condition must be reported to maintenance control.

SPECIAL INSPECTION

The special inspection is performed at intervals of 7, 10, or 14 days, depending on the type of aircraft. In-service parachute assemblies installed in aircraft and in ready issue rooms are also given this special inspection. This inspection includes the integrated torso harness and quick attachable harnesses. The daily inspection is included as part of performing the special inspection. Assemblies used for training, parachute rescue, pathfinding, and reconnaissance teams, and those parachute assemblies not assigned to a specific type of aircraft are inspected every 14 days. It is done by organizational level maintenance PR personnel, such as yourself, and conducted only under adequate lightning conditions.

This inspection includes, but is not limited to, emergency aircraft escape assemblies and/or systems, as well as assemblies used for pre-meditated free-fall or static line parachute descents. The reserve (emergency) parachute, which may form a part of a training-type, troop-type, or a test assembly, is also inspected. Parachute assemblies are not opened for the special inspection or for the daily inspection. If you find or suspect any damage or contamination, notify maintenance control. When you complete the special inspection, enter your full name, rate, and current date on the Preflight/Daily/Turn-around/Postflight Maintenance Record Card.

ACCEPTANCE (ORIGINAL ISSUE) CALENDAR/PHASED/CONDITIONAL INSPECTIONS

The acceptance (original issue)/calendar/phased/conditional inspection is performed at the lowest level of maintenance possible. These inspections include, but are not limited to, aircraft emergency escape assemblies and/or systems.

Original Issue/Acceptance

The original issue inspection is performed at the time a parachute is placed into service. The original issue inspection consists of a visual inspection of the assembly and a repack of the parachute assembly in accordance with the applicable work package. When a parachute assembly is an aircraft inventory item, the acceptance inventory inspection serves as the original issue inspection. In this case, the packed parachute assembly is visually inspected for damage, and the records concerning the parachute are examined for discrepancies or missing information. If any discrepancy is found, a conditional inspection, which includes a repack of the parachute assembly, is performed.

Calendar/Phased

The regular inspection cycle of a parachute assembly should correspond either to the aircraft calendar inspection or to the phased maintenance inspection cycle program, as directed by NAVAIR 13-600-4-6.3. You should ensure the parachute assembly inspection period does not expire before the scheduled maintenance period of the aircraft. To meet unusual situations and facilitate workload scheduling, a plus or minus 1 week, or portion thereof, may be applied to the authorized inspection interval. To enable a ferry flight to return to home station/ship after an away from home grounding discrepancy of such duration that inspection interval expired, necessary additional days maybe added. However, in each instance deviations apply only to the immediate inspection due. If unusual circumstances dictate deviations of succeeding inspection intervals, each deviation must be computed from the date on which the inspection would have been due if the preceding deviation had not been granted.

Conditional Inspection

When a parachute assembly must be inspected as the result of a specific situation or set of conditions unrelated to the normal inspection interval, a conditional inspection is performed.

Postcombat Inspection

Organizational-level maintenance inspects parachute assemblies for external damage or abnormal condition after each combat mission. When an aircraft has been subjected to gunfire,

all parachutes are examined for damage prior to the next flight. If bullets or fragments have entered the parachute assembly, you must remove it from service and perform a conditional inspection.

Aircraft Accident Report Inspection

Any personnel parachute, along with related subassemblies or equipment (pilot parachutes, stabilization parachutes, containers, harnesses, cushions, automatic parachute ripcord release assemblies, ballistic spreading guns), that has been recovered following use in an emergency bailout or ejection must be returned to the nearest naval supply activity for shipment to the Commanding Officer, Naval Weapons Center (NWC), China Lake, California. The parachute must be in the same condition that it was when recovered. Do not chain the lines. You do this in the event that an engineering investigation is necessary by NWC. Stencil on the outside of the shipping container in 1-inch letters the following: "THIS EQUIPMENT HAS BEEN USED IN AN EMERGENCY SITUATION." These items are required so that a design deficiency can be detected, or to establish requirements for product improvements.

OPNAV 3750.6 gives procedures you must follow to provide the Naval Weapons Center with sufficient information to properly evaluate and improve these parachutes for service use. In accordance with this instruction, you will give NWC the following information:

1. Name of submitting activity and AAR number
2. Date, time, and place of use
3. Name, rank/rate, serial/service number of user
4. Model aircraft, altitude, attitude, airspeed, and sink rate at time of ejection or bailout (if known)
5. Type of parachute and serial number of canopy assembly
6. Type and model designation of ejection seat (if applicable)
7. Type of automatic parachute ripcord release and serial number
8. A brief narrative summary of any difficulties with the personnel parachute equipment and/or automatic actuator or other additional information that may be applicable

Also include the Parachute Configuration, Inspection, and History Record and any reference information or documents that would have a bearing on a technical investigation. If the aircrewman sustained fatal or serious injuries during the escape or recovery sequence, include photographs of the parachute, ejection seat, and other components at the scene of the impact.

Ensure the proper shipping tags and labels are attached to all equipment and the shipping container. If pyrotechnics or explosives are in the package, it should be noted on the outside of the container.

PROCEDURES FOR PRELIMINARY TESTS AND INSPECTIONS

When you are assembling a parachute for an original issue inspection or performing a normal calendar repack, you will have to do some preliminary test and inspections that are common to all personal parachutes. These inspections and tests are discussed in the following text.

RIPCORDER PULL TEST

Parachutes must be given a ripcord pull test before being unpacked for inspection. The maximum pull force that you may use is 27 pounds. If you go over 27 pounds, the ripcord pins, cones, and grommets must be checked for bends, dents, and roughness, and make sure that the ripcord cable moves freely in the housing. Inspect the housing for sharp bends or dents and replace any damaged parts. Silicone spray may be sparingly applied to ripcord parts. Make sure that ripcord pins are properly positioned before testing. All assemblies with metal ripcord handle clips require an additional test. To do this, use a straight pull to remove the handle from the clip; this will require 10 to 20 pounds of force. If not within limits, use pliers to adjust the clip.

SERVICE LIFE CHECKS

Testing the ripcord opens the container. If the assembly includes explosive devices, they must be deactivated at this time. The canopy is then placed on the table with the nameplate up. If the parachute is being placed in service, the date is stenciled on the parachute canopy on the nameplate gore directly below the nameplate.

For a periodic inspection, you should verify the nameplate data against the Parachute

Configuration, Inspection, and History Record, or "History Card." If the service life dates listed on the history card are in accordance with the *Maintenance Requirement Cards*, NAVAIR 13-600-4-6-3, check their expiration dates against the current date of inspection. Items that have reached service life limits must be replaced. Items that will become overage after the assembly is repacked may remain in service until the next inspection date of the complete assembly. An exception to this are the explosive devices, which must be replaced if their expiration date will be reached before the next inspection.

REPLACEMENT OF PARACHUTE ASSEMBLIES AND SUBASSEMBLIES

Not all the components of a parachute assembly come to the end of their service lives at the same time. After a parachute has been in service for some time, some of the components or subassemblies will have to be replaced in the course of the periodic inspections.

If you find an assembly or subassembly that has reached the service/total life limit, it should be returned to supply for appropriate disposition according to current supply instructions. Before turning an overage assembly in to supply, you should remove all serviceable ready for issue (RFI) subassemblies. You should carefully inspect all nylon webbing and cloth on items to be salvaged. Dirt, oil and grease greatly weaken these materials. All fabric items salvaged must have date of manufacture and date placed into service markings verified prior to disassembly. Cartridges used on cartridge-actuated parachutes are to be handled, shipped, stored or disposed of in accordance with NAVAIR 11-100-1. When an in-service parachute does not have a start of service date, the service life from date of manufacture expires as follows: in 7 years for emergency use parachute assemblies; in 10 years for troop and training assemblies.

CONTAMINATION INSPECTION

Contamination of a parachute canopy or an assembly could result in the malfunction of the complete assembly. It is very important that you be able to recognize a harmful stain. All parachute assemblies must be carefully inspected for the following types of contamination:

1. Acid/alkaline
2. Salt water

3. Perspiration
4. Freshwater
5. Mildew/fungus
6. Fire-fighting agent
7. Petroleum products
8. Bloodstains
9. Mud/dirt/sand/trash

Acid and Alkaline Contamination

If a parachute assembly is suspected of having acid or alkaline contamination, it must be tested with a pH test paper. A pH reading of 5.0 to 9.0 is in the safe zone. Readings below 5.0 indicate excess acidity, and readings above 9.0 indicate excess alkalinity. By following the steps listed below, you will be able to conduct a proper inspection to determine if a stain is acid or alkaline. You need to have distilled water and a pH test paper kit (full range and short range).

CAUTION

MAKE SURE THAT THE TESTING AREA IS FREE OF CONTAMINANTS TO AVOID FALSE READINGS OR DAMAGE TO THE ASSEMBLY.

To perform an acid and alkaline contaminant inspection properly, you should take the following steps:

1. First, dampen the suspected area with distilled water.
2. Place a piece of full-range test paper (0.0 to 14.0 pH) on the dampened area. Compare the color of the paper with the chart samples to determine the approximate pH and which specific short-range test paper to use.
3. Place the short-range test paper indicated by step 2 on the dampened area. The color the paper changes to will indicate the pH factor of the affected area. By matching the test strip with the applicable range color chart supplied with the pH indicator kit, you can determine the strength of the acid or alkaline present.

NOTE: You must be careful not to let the suspected contaminated area come into contact with any other area, as this could spread the damage.

4. Treat contaminated areas of the parachute assembly in accordance with NAVAIR 13-1-6.2.

Other Contaminations

Those stains caused by contact with acid, oil, and salt water are the most harmful to nylon and should be removed as quickly as possible to prevent further deterioration of the material. Although sun rays do not stain, they are most harmful to nylon. Parachutes and components must be kept out of the direct sunlight.

INSPECTING FOR WEAR AND PHYSICAL DEFECTS

Wear in a parachute is not difficult to detect. Chafing at the comers or on outside surfaces is where the most wear occurs. Parts of parachutes and related equipment showing excessive wear should be replaced or repaired, the work to be accomplished at the lowest maintenance level capable of performing the task.

PILOT PARACHUTE INSPECTION

Inspect the fabric drag surfaces, rib pockets, lift webs, seams, and suspension lines for signs of contamination, cuts, tears, burns, fraying, and loose or missing stitches. Inspect the vane material for defects and deterioration. Inspect for seam separation along the seam area where the vane attaches to the cone and suspension lines. Yarn separation is acceptable; however, replace the pilot chute if the vane material contains holes, rips or tears. Inspect the spring assembly for sufficient tension and bends. Replace ail loose or broken tackings. There is little that you can repair on a pilot parachute. If any damage is found, you must replace the pilot parachute in accordance with NAVAIR 13-1-6.2.

CANOPY INSPECTION

Inspecting the canopy requires the most time. You must take your time in order to be certain that you don't miss any defects. NAVAIR 13-600-4-6-3 and NAVAIR 13-1-6.2 spell out the step-by-step procedures for this inspection. Any damage must be recorded on a canopy damage chart. (See figure 1-15.) To inspect the canopy for possible defects or damage, you should take the following steps:

1. Lay the canopy on a clean packing table so its nameplate gore is facing down.
2. Place tension on the canopy.

3. Have your helper raise the suspension line. Use Y-stands at the skirt hem to hold the suspension lines.

4. You, as the packer, start at the skirt hem and inspect the upper radial seam from skirt hem to peak. You inspect the vent hem, collar and ring, lower radial seam, fabric surface, diagonal seams or tapes, and skirt hem. Minor defects that do not weaken the assembly are not reported on a canopy damage chart. If necessary, minor defects may be corrected by light brushing or trimming.

5. Significant damage and major defects, such as holes, rips, tears, or contaminated areas that have to be removed, are reported on the canopy damage chart.

Use the same procedures to inspect all canopy gores.

SUSPENSION AND VENT LINE INSPECTION

To inspect the suspension lines, you and your helper grasp one group of suspension lines at the connector links and walk toward the canopy skirt hem, allowing the lines to run freely over the palm of your hand. Visually examine the lines for damage and defects. Upon reaching the skirt hem, grasp the remaining groups of lines and inspect them the same way, walking toward the connector links. The lines at the canopy vent are also visually examined. Your inspection includes, but is not limited to, the following:

1. General condition of the suspension lines including fraying, ruptures, inner cores protruding from lines; dirty, lumpy, hard or thin spots; friction bums; improper overlap length; presence

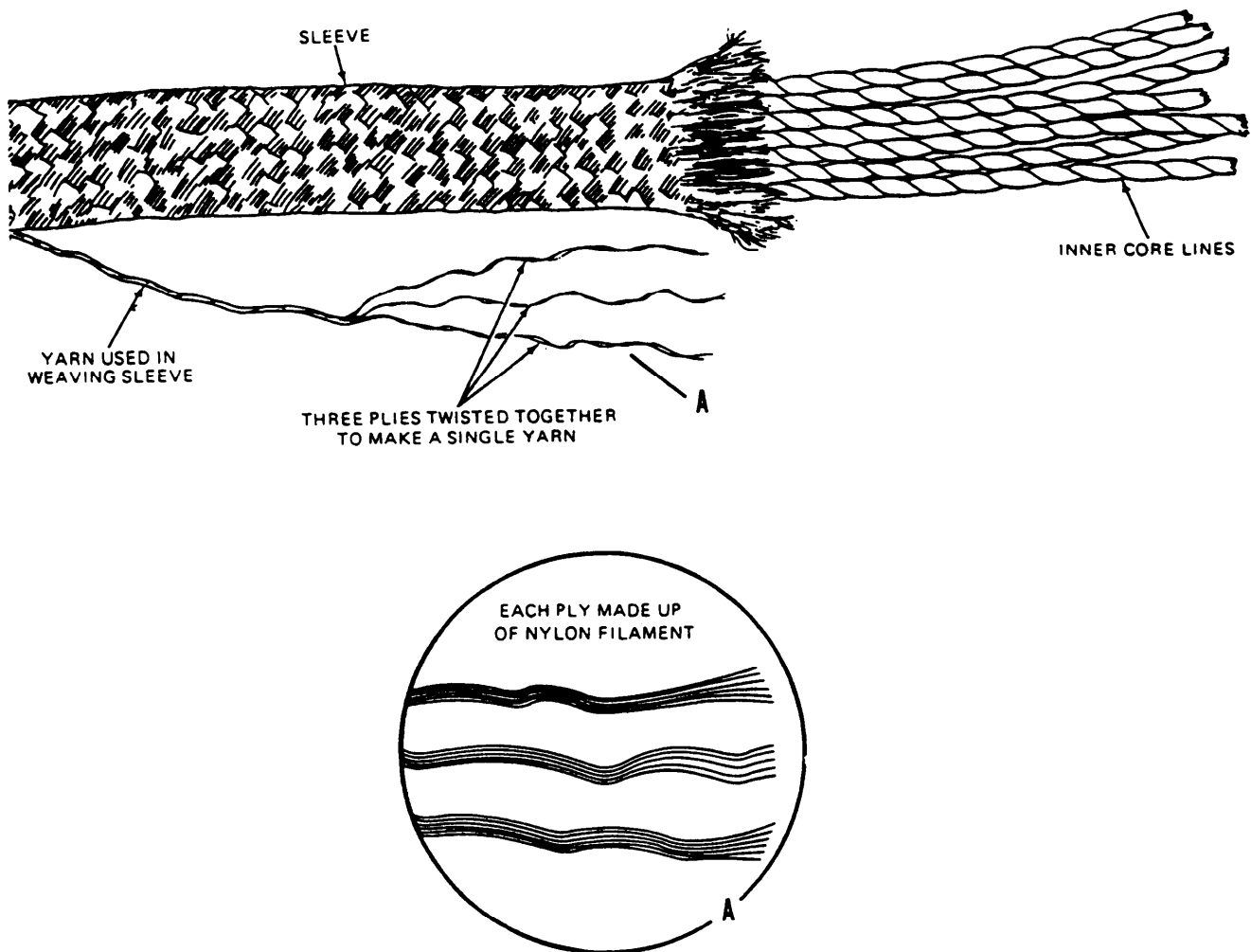

Figure 1-16.—Suspension line construction.

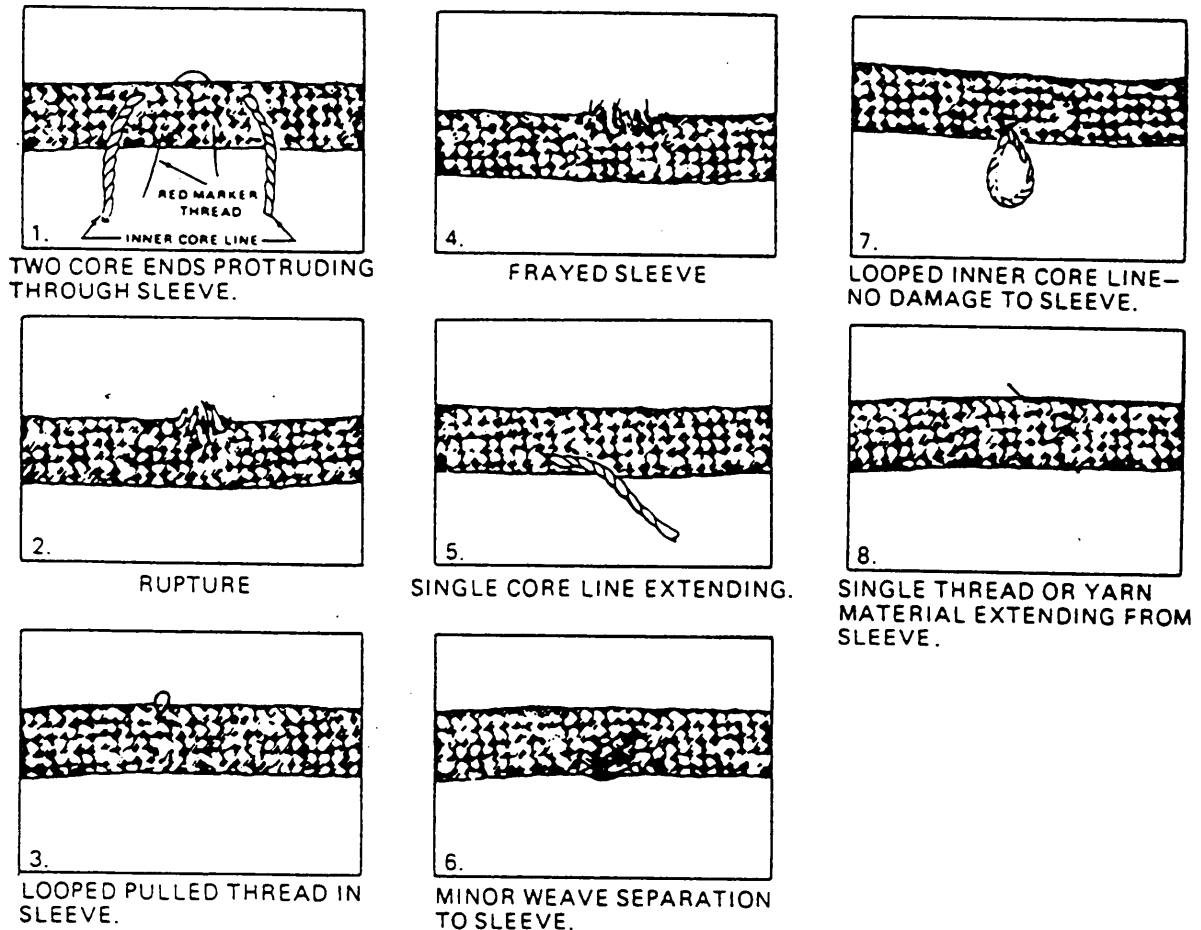

Figure 1-17.—Suspension line damage.

of twists in individual lines; and the proper sequence of lines on the connector links. To help you decide on the various types of damage, see the examples in figures 1-16 and 1-17.

2. Be sure that each of the suspension lines is in proper rotation at the connector links and through the canopy.

3. On an original issue inspection, you must measure the suspension lines for proper length. Apply a 20-pound tension to each line. The length of the shortest line and the length of the longest line must not vary more than 2 inches.

4. Inspect the attachment at the skirt hem for thin spots at the V-tabs; also, check the condition of the V-tabs.

5. Inspect the four line release system. The four line release system permits four of the suspension lines on one side of the parachute to be detached from the connector links during a

parachute descent. This permits the parachutist to dampen oscillations and to have some control over the direction the parachute travels when descending.

6. Other defects should be noted on the Parachute Configuration, Inspection and History Card. If a defective line is found that would affect the safe operation of the assembly, the line must be replaced at a depot-level maintenance activity.

CONNECTOR LINK INSPECTION

To inspect connector links, you should proceed as follows:

1. First, examine the connector links for proper part numbers, signs of corrosion, distortion, bends, dents, nicks, burrs, sharp edges, breaks, and if applicable, defective yoke and plate assemblies.

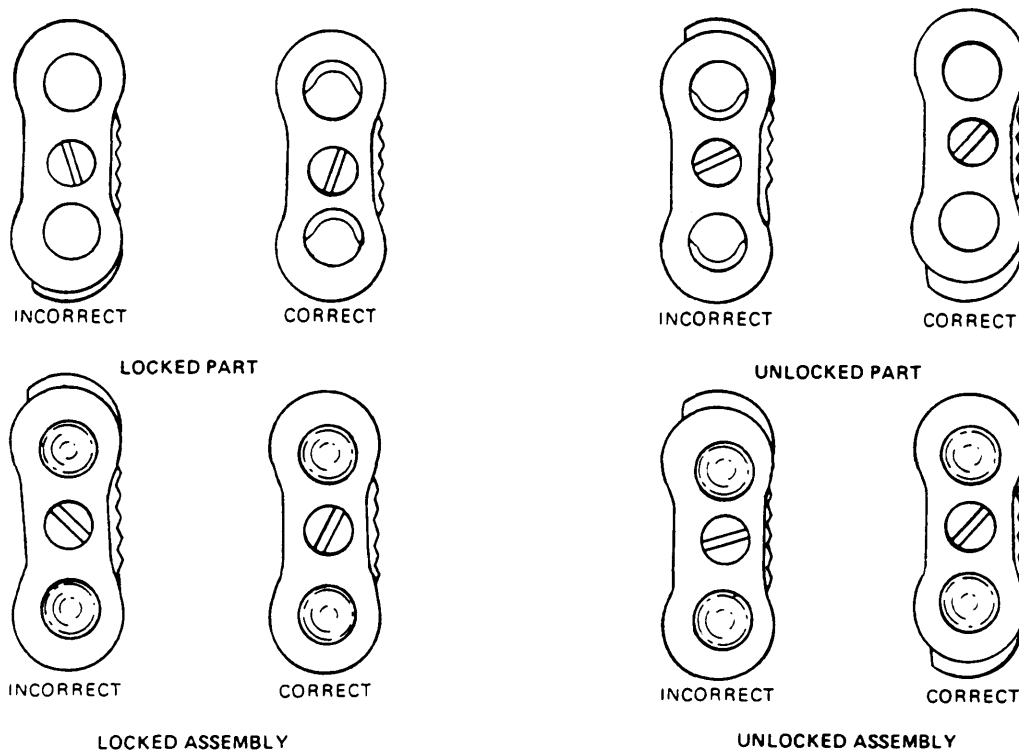

Figure 1-18.—Locked and unlocked connector links.

2. If required, examine the yoke and plate assembly for proper installation (fig. 1-18). When the yoke and plate assembly screw is tightened, there should be a maximum of 1/64-inch play in the assembly. (To tighten the screw use a torque of 20 to 25 lb-in.)

At this point, a mandatory inspection is performed by a quality assurance inspector. All of your work stops until the mandatory inspection is performed and the assembly has been found acceptable.

BALLISTIC SPREADING GUN INSPECTION

While inspecting the ballistic spreading gun, you may have to remove, replace, or make some adjustment. All work must be in accordance with the procedures in the applicable chapter of the NAVAIR 13-1-6.2. The ballistic spreading gun is described in the next chapter of this text.

HARNESS/RISER ASSEMBLY INSPECTION

Inspect the harness webbing for signs of contamination from oil, grease, acid, or other

foreign matter, such as rust at points of contact with metal parts. Inspect for cuts, twists, fading, excessive wear or fraying (indicated by unusual hardening or softening of webbing fibers), fraying, burns, abrasions and loose or broken stitching (in excess of three stitches). If applicable, inspect the four-line-release lanyard flute for wear and proper attachment. If you find any damage to the harness, dispose of it and replace it in accordance with applicable rigging and packing procedures.

When a replacement harness is installed, you should stencil the date, preceded by the letter *R*, in the center of the horizontal back strap in letters 1/2-inch high. For example, R-2-88 indicates a replacement was made in February 1988.

If fewer than three stitches are loose or broken, repair the riser or harness assembly by using nylon 6-cord, lock-stitch over original stitch and 3/4 inches on both sides of the original. Use four to six stitches per inch.

Hardware Inspection

To inspect harness and riser hardware, proceed as follows:

1. Inspect the canopy quick-release fittings for breaks, corrosion, pitting, bends, dents, and sharp

edges. Check the tamper-dot on the locking screw. If it is broken, tighten it and apply a new tamper-dot to the screwhead using lacquer (TT-L-32, 11136, insignia red) or equivalent. Remove sand or any dirt from the mechanism using an air hose to blow it out at not more than 50 psi pressure. Wipe dirt and grease from fittings with a clean rag. Do not lubricate the fittings. Replace all damaged fittings.

2. With the canopy quick-release fitting locking cover plate held in the open position, insert a torquemeter into the hexagonal cavity located on either end of the knurled locking-lever shaft. With the canopy quick-release fitting locking cover plate held in the open position, rotate the knurled lever shaft until it reaches the stop. Record the torque reading. The allowable torque is 28 to 50 ounce-inches. All canopy quick-release fittings that do not meet torque test requirements must be replaced.

3. Inspect all other hardware for signs of corrosion, pitting, ease of operation, security of attachment, bends, dents, nicks, burrs and sharp edges. Make sure that the rollers in the roller yokes turn freely. If you find any parts damaged, forward the riser or harness assembly to supply for screening.

NOTE: Hardware that has been rejected is forwarded to the Commanding Officer, Naval Weapons Center, China Lake, California, Attention: Code END, 4.

Cross-Connector Strap Inspection

Inspect the cross-connector strap(s) for signs of contamination, cuts, fraying, burns, and loose or broken stitching. If you find any damage, dispose of them locally, and replace them in accordance with applicable rigging and packing procedures.

RIPCARD ASSEMBLY INSPECTION

The ripcord was inspected before the parachute was unpacked. Now it is inspected again. To inspect the ripcord assembly, examine the following:

1. Inspect the ripcord handle. Examine the cable and locking pins for signs of corrosion,

bends, dents, cracks, loose swage joints, and breaks. If damaged, dispose of it locally.

2. Inspect the ripcord housing for signs of corrosion, bends, dents, and for security of attachment. If any damage is found, replace the housing.

3. Inspect the ripcord housing release clamp and baseplate for signs of corrosion, bends, dents, cracks and security of attachment.

4. Inspect the ripcord housing release lanyard and guide for signs of contamination, tears, fraying, loose or broken stitches, cuts, burns, correct length and security of attachment.

5. If you find any loose or damaged tackings, they must be replaced.

Ripcord Handle Pocket Inspection

Inspect the ripcord handle pocket for signs of contamination, cuts, tears, burns, fraying, and loose or broken stitches. If such damage is found, the pocket is replaced. You have an option on how the new pocket can be installed. You may install a new pocket by machine stitching, using nylon thread, size E (V-T-295), or by whip stitching, using waxed nylon 6-cord, type I, doubled, stitches being 3/8-inch apart.

Ripcord Handle Clip Inspection

To inspect the ripcord handle clip, you should do the following:

1. Examine the clip for corrosion, sharp edges, bends, twists, and dents. Examine the webbing for contamination, fraying, loose or broken stitching, cuts and burns. Replace any damaged stitching. If other damage exists, replace webbing and/or clip.

2. If any maintenance is performed on the clip, repeat the pull-force test outlined in NAVAIR 13-600-4-6-3 and described earlier in this chapter.

CONTAINER ASSEMBLY INSPECTION

When you inspect the container assembly, examine all flaps, locking cones, and grommets, spring opening bands, and tackings; checking

fabric, seams, reinforcement, and hardware. Check fabric, seams, webbing and reinforcement for holes, cuts, tears, fraying, contamination, and deterioration. Examine hardware for corrosion, bends, dents, nicks, sharp edges, proper function, and security of attachment. Make sure that you keep a record of any damage for later repairs. Repair holes, tears, snags, or rips in container fabric using approved procedures as described in NAVAIR 13-1-6.2.

Some parachute containers use rubber retaining bands to secure the suspension lines. On most assemblies these rubber bands must be replaced at each repack regardless of their condition.

COMPLIANCE WITH CURRENT DIRECTIVES

On parachute repack cycles, or when otherwise directed, inspect the parachute assembly and components for updating according to the latest modifications. For each type of parachute, refer to the *Emergency Personnel and Drogue Parachute Systems Manual*, NAVAIR 13-1-6.2, and recent Aircrew System bulletins and changes for all current parachute configurations. Do not permit any local modifications without prior approval by proper authority.

CHAPTER 2

AUTOMATIC OPENING DEVICES

Learning Objective: Upon completion of this chapter, you will be able to recognize, inspect, and maintain cartridges and cartridge-actuated devices used with personnel emergency parachute assemblies.

As you look around the parachute loft, you will see that it is a very clean, neat, and safe-looking place to work. Although it has this appearance, there are a few places that are very dangerous. One of the more hazardous places is the packing table. The packing table may look as safe to you as sitting at home in your easy chair watching television. However, on the packing table you will find automatic opening devices. There are two basic opening devices used in the operation of personnel parachutes.

The first is the automatic parachute ripcord release. Working with this actuator is the same as working with a loaded .38 caliber pistol. The second is the ballistic spreader gun. This gun has a cartridge; and when fired, it gives the same effect as an exploding hand grenade. Working with any opening device requires extreme caution—all safety precautions must be taken to ensure your safety as well as that of your coworkers. This chapter will help you understand the operation, function, and maintenance of this equipment.

AUTOMATIC PARACHUTE ACTUATORS

The Navy currently uses the Model 7000 automatic parachute ripcord release (fig. 2-1) in its personnel parachute assemblies. It is a barometrically controlled, pyrotechnic device. The actuator is designed to open a parachute at a preset altitude. The Model 7000 automatic parachute ripcord release is available with two different altitude settings. One is the 10,000-foot setting, plus or minus 1,000 feet (identified by green labels on the cover assembly). The aneroid is identified by a green potting seal and a white

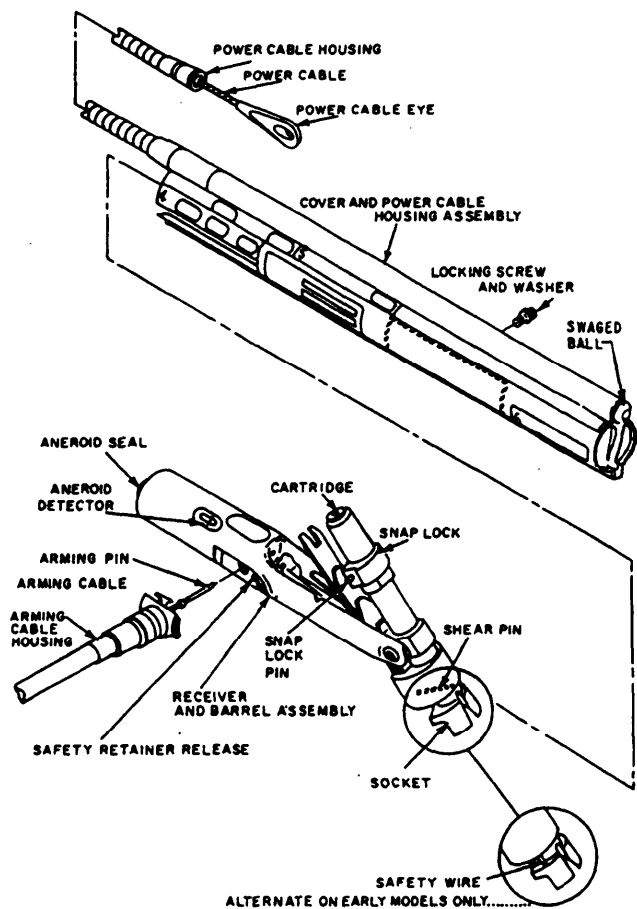

239.266

Figure 2-1.—Model 7000 Automatic Parachute Ripcord Release.

label with green lettering. The other is the 14,000-foot setting, plus or minus 1,000 feet (identified by red labels on the cover assembly). The aneroid is identified by a red potting seal and a white label with red lettering.

FUNCTION

It is impossible for an aircrewman to select the altitude at which an emergency may occur. By using the automatic ripcord release, you can bring the aircrewman down to a safe altitude before the parachute opens.

When an aircrewman makes an emergency ejection at an altitude above that for which the ripcord release is set to open the parachute, the following functions take place:

1. The arming pin is pulled. This pin locks the ripcord release firing mechanism while installed. When the arming pin is withdrawn, the assembly fires at or below the preset altitude of the ripcord release.

2. The sear and the aneroid mechanism lock the ripcord release.

3. As the aircrewman free-falls, increasing air pressure causes the aneroid to contract.

4. As the operating altitude is reached, the aneroid contracts enough to remove the sear from the firing hammer lock.

5. The hammer's firing pin strikes the cartridge.

6. The time-delay cartridge fires (time depending on the type of cartridge used) after the hammer strikes.

7. The piston is forced forward in the barrel, pulling the power cable, which is attached to the parachute locking pins. (The power cable travels 3.75 inches.)

8. The locking pins are pulled, and the normal parachute opening sequence begins.

When an aircrewman bails out below the operating altitude of the automatic parachute ripcord release, the hammer releases as soon as the arming pin is pulled, and the following functions take place:

1. The hammer's firing pin strikes the cartridge.

2. The time-delay cartridge fires (time depending on the type of cartridge used) after the hammer strikes.

3. The piston is forced forward in the barrel, pulling the power cable, which is attached to the parachute locking pins.

4. The locking pins are pulled, and the normal parachute opening sequence begins.

PREPARATION FOR USE

When you receive an automatic parachute ripcord release from supply, there are some preparations for you to make before placing it into service. Upon removal of the ripcord release from the shipping carton, the exterior parts of the unit must be inspected for damage during shipping and storage. An inspection should be made for corrosion, dirt, dents, and cracks. If any damage or discrepancy is found, a quality deficiency report must be submitted, and a tag must be affixed to the ripcord release stating that it is not to be used. Remove this tag only after correction has been made. Fired ripcord release assemblies must not be reused.

All Model 7000 automatic parachute ripcord release assemblies that fail any inspection points must have a tag affixed stating the nature of the defects.

NOTE: Refer to NAVAIR 11-100-1.1 for the cartridge service life/total life. The cartridge service life must not expire prior to the next scheduled repack of the parachute assembly.

WARNING

YOU SHOULD EXERCISE EXTREME CAUTION WHEN HANDLING AUTOMATIC RIPCORD RELEASE ASSEMBLIES AFTER THE CARTRIDGE HAS BEEN INSERTED IN THE BARREL. DO NOT ALLOW EITHER END OF THE COVER ASSEMBLY TO BE POINTED TOWARD YOUR FACE AS HIGH VELOCITY FLAME AND SMOKE MAY BE PRODUCED IF THE CARTRIDGE GOES OFF. ANOTHER REASON FOR EXTREME CAUTION IS THE POSSIBILITY THAT THE PISTON OF THE RIPCORD RELEASE MAY BECOME A PROJECTILE IF THE CARTRIDGE ACCIDENTALLY FIRES.

An automatic ripcord release in service must be inspected each time its parachute assembly is repacked. You must pay particular attention to detail when working on a automatic ripcord release. The importance of careful work must be impressed upon personnel actually performing the work, as well as those assigned to collateral duty

inspections. You will find more detailed information concerning automatic parachute ripcord release assemblies in the *Emergency Personnel and Drogue Parachute Systems Manual*, NAVAIR 13-1-6.2, and the *Maintenance Requirements Cards*, NAVAIR 13-600-4-6-3.

MAINTENANCE

Maintenance on any automatic ripcord release in service must be performed each time its parachute assembly is repacked. Maintenance consists of the following:

- Disarming
- Inspection
- Firing altitude check
- Arming and assembly
- Checkout of armed mechanism

As you work on a automatic ripcord release assembly, you are required to perform several different types of maintenance and inspections. You are required to inspect the operational condition of the automatic ripcord release before installing it in a parachute assembly. If you find any damage or an inspection discrepancy, submit a quality deficiency report, as discussed in OPNAVINST 4790.2 (series).

NOTE: Under no circumstances should an unsatisfactory ripcord release be installed.

The first step in performing the normal inspection and maintenance on a automatic ripcord release is to disarm it. Then you are ready to inspect and perform the firing altitude checks.

DISARMING

Anytime you are required to disarm a ripcord release assembly, follow the procedures outlined in NAVAIR-13-1-6.2. The discussion that follows closely parallels those procedures. A parts breakdown can be seen in figure 2-1.

NOTE: To remove the arming cable housing from the ripcord release, depress the safety retainer release (fig. 2-1). NEVER try to remove the arming cable from an armed ripcord release assembly by pulling on the cable. This fires the automatic ripcord release.

1. Open the ripcord release pocket, and remove the ripcord release only a sufficient distance to allow disassembly.

2. Remove the locking screw and washer.

NOTE: The cover and power cable housing assembly and the receiver and barrel assembly are serialized matched sets. Do not mix these assemblies.

3. Slide the cover off the receiver and barrel assembly.

4. Disengage the barrel snap lock. A close-up of this operation is shown in figure 2-2.

5. Remove the cartridge from the barrel assembly (fig. 2-1). Do not proceed until the quality assurance inspector (QA) has verified this step.

6. Remove the ripcord release assembly and the arming cable housing from the parachute container.

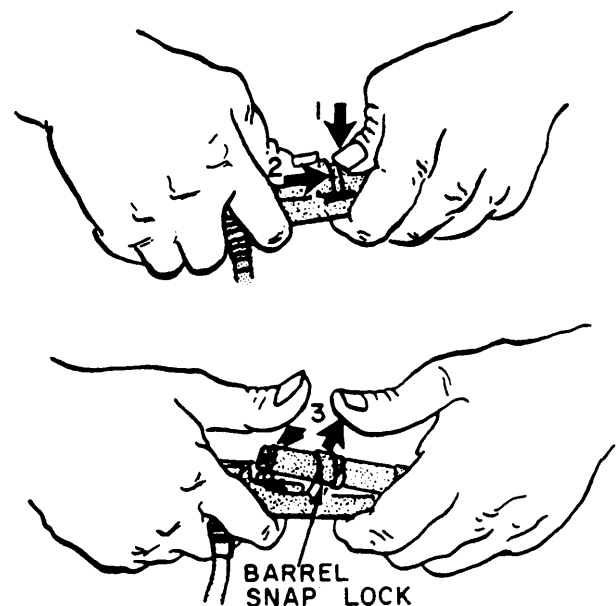

239.227

Figure 2-2.—Disengaging barrel snap lock.

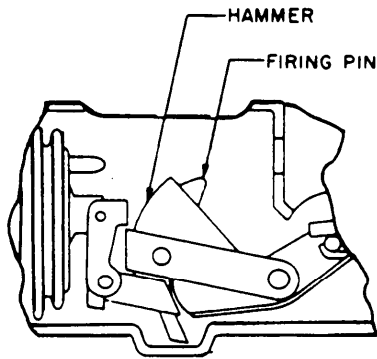

Figure 2-3.—Checking firing pin and hammer.

INSPECTION

To inspect the automatic ripcord release, proceed as follows:

1. Inspect the cover and power cable housing assembly for nicks, gouges, distortion, corrosion, and security of the power cable housing.
2. Inspect the power cable for freedom of movement, and secure attachment of the swaged ball and power cable eye.
3. Inspect the receiver and barrel assembly for excessive nicks, cracks, gouges, distortion, and corrosion or other damage that could cause a malfunction while in service.
4. Inspect the firing pin on the hammer for flattening, gouges, or other damage (fig. 2-3).
5. You must secure the arming pin by inserting the pin in the retainer while the barrel is unlocked. Press the pin firmly into place until it locks into the pin groove. The pin should now be held securely. Do not twist the socket as this will break the shear pin.

NOTE: Early Model 7000 automatic parachute ripcord release assemblies use safety wire, as shown in figure 2-1. When inspecting these assemblies, check for security and the proper type of wire.

6. Inspect the socket for visible damage and retention of the socket and piston by a shear pin (figs. 2-1 and 2-4).

7. Inspect the snap lock pins for security and absence of damage (figs. 2-1 and 2-5).

NOTE: If the tamper dot is broken, you need to torque the screw to a value of 14 1/2 to 15 1/2 inch-pounds and apply a new tamper dot.

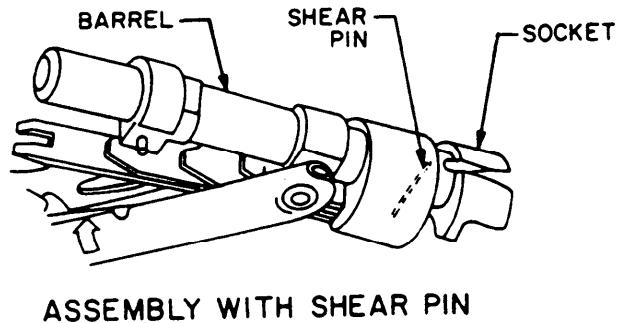

Figure 2-4.—Checking for proper retention of socket by a shear pin.

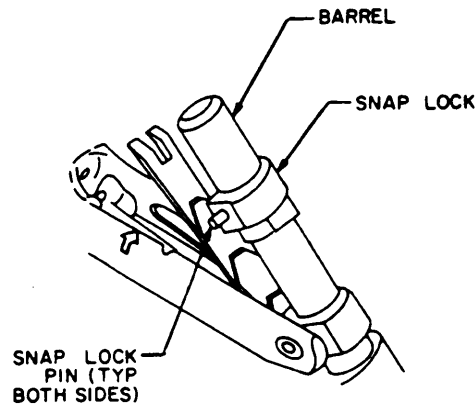
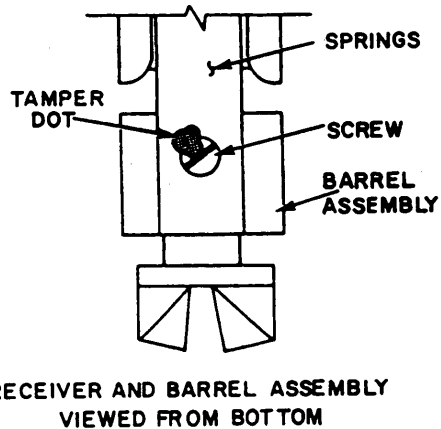

Figure 2-5.—Checking for security of snap lock.



RECEIVER AND BARREL ASSEMBLY
VIEWED FROM BOTTOM

239.229

Figure 2-6.—Checking springs and tamper dot.

8. Inspect the leaf springs on the receiver and barrel assembly for damage. Make sure the retaining screw has not loosened. (Check the tamper dot on the screw and spring, as shown in figure 2-6.)

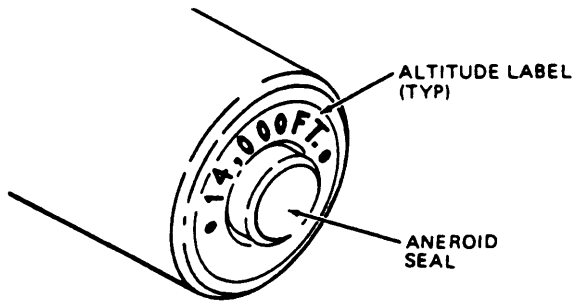

Figure 2-7.—Inspecting aneroid seal.

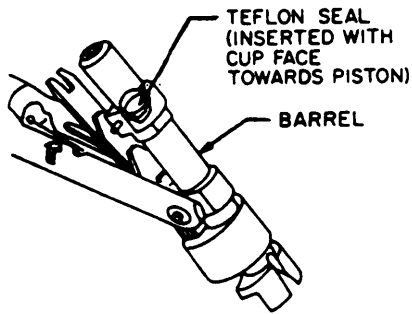

Figure 2-8.—Inspecting gasket seal.

9. Check the sealing compound on the aneroid screw, shown in figure 2-7. The seal must be intact and undisturbed. Cracks due to normal aging of seal material are acceptable.

10. Inspect the Teflon seal. Be sure that the cup side of the seal is facing the piston (fig. 2-8).

FIRING ALTITUDE CHECK

To check for the proper firing altitude of the automatic ripcord release, you must first be familiar with the automatic parachute ripcord release test set.

AUTOMATIC PARACHUTE RIPCORD RELEASE TEST SET

The automatic parachute ripcord release test set, shown in figure 2-9, is designed to test the sensitivity of the automatic ripcord release to a preset pressure altitude through use of an aneroid blocking mechanism.

The principal action that you test is the consistency of the aneroid in actuating the release mechanism at a predetermined altitude. To do

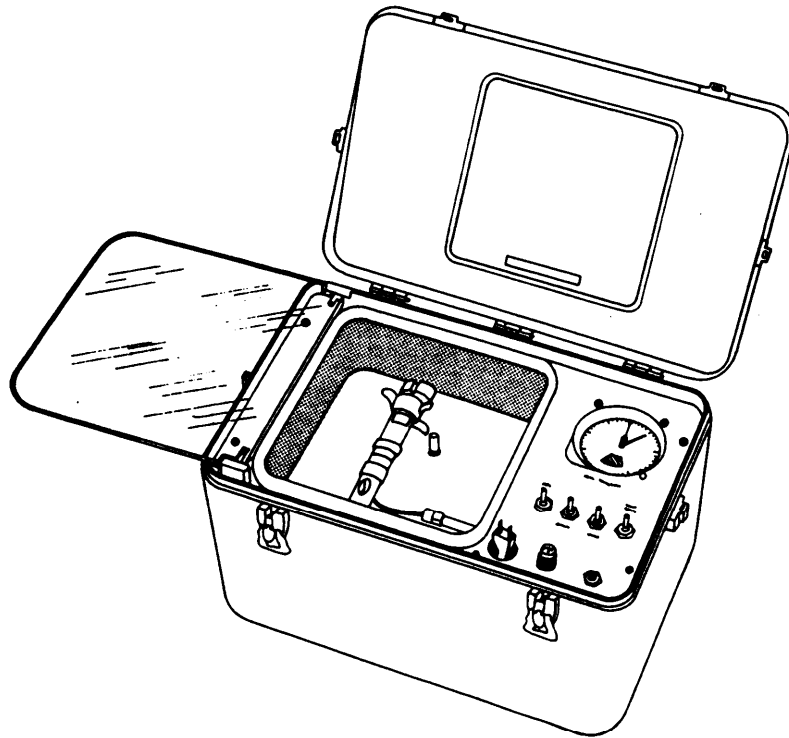

Figure 2-9.—Automatic parachute ripcord release test set.

239.118

this, you first evacuate air from a test chamber to simulate an increase in altitude. When you have achieved a simulated altitude above the preset altitude of the ripcord release, you extract the arming pin, which arms the parachute ripcord release firing mechanism. Then you bleed outside air back into the test chamber at a controlled rate to simulate a specific rate of descent. When the pressure reaches the value for which the automatic ripcord release has been set, the aneroid will unlock the sear if the pressure sensitivity is within tolerance.

The test chamber, its evacuation system, instrumentation, and controls are packaged in one container. The test chamber is designed to withstand a vacuum equivalent to an altitude of 30,000 feet. The chamber holds the entire 7000 series automatic parachute ripcord release, and it includes the necessary brackets to support and position the ripcord release within the chamber during the test cycle. An access door/observation window is also provided.

NOTE: Before testing an automatic parachute ripcord release, the test chamber altimeter should read 29.92 inches of mercury barometric pressure.

RIPCORD RELEASE TEST PROCEDURE

Plug the test unit's power cord into a 115-volt, 60 Hz, ac power source. Place the power switch in the ON position, open the test chamber door, and insert the arming pin cable into the side of the ripcord release with the aneroid end toward the operator.

To test the ripcord release, follow these procedures:

1. Ensure the test chamber has been calibrated. Install the test chamber substitute arming pin into the ripcord release. If the barometric pressure reading of the altimeter isn't 29.92, you will not get a true reading of the firing altitudes. Therefore, you must adjust the altimeter to the proper setting when required.

2. Install a dummy cartridge.

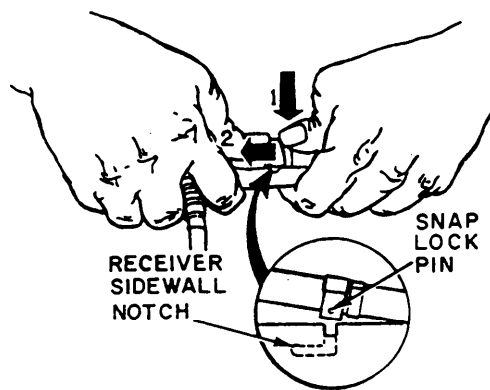

239.228

Figure 2-10.—Locking barrel assembly.

CAUTION

DO NOT RELEASE THE RIPCORD RELEASE FIRING MECHANISM WITHOUT A DUMMY CARTRIDGE INSTALLED, AS THIS COULD DISTORT THE FIREWALL. THIS DISTORTION COULD CAUSE A LATER MALFUNCTION.

3. Press the barrel down into position in the receiver. As the barrel reaches the proper position, exert forward pressure on the snap lock, causing the snap lock pins to lock the barrel in position (fig. 2-10).

4. Install the barrel and receiver into the test chamber. Check your altimeter (fig. 2-9) for a setting of 29.92.

5. Evacuate the chamber to an altitude of 25,000 feet. This is done by using the climb toggle switch.

6. Decrease the altitude by using the descend toggle. The chamber simulates descent at a rate of 175 to 200 feet per second.

7. At approximately 20,000 feet actuate the arm toggle switch to withdraw the arming pin from the barrel and receiver.

8. At the firing altitude the ripcord release should fire. (You have a tolerance of plus or minus 1,000 feet at this time.)

9. Record the altitude at which the ripcord release assembly's firing pin strikes the dummy cartridge. The firing altitude is recorded on the parachute configuration, inspection, and history record. The quality assurance inspector will check this point of the procedure.

WARNING

AFTER TEST FIRING, YOU MUST NOT USE A METAL TOOL TO PUSH THE HAMMER AND LOCK ASSEMBLY BACK FROM THE FIRING WALL. TAKE EXTREME CARE TO AVOID SCRATCHING OR ABRADING THE POLISHED SURFACE OF THE LOCK. THE PURPOSE OF THE LOCK ASSEMBLY IS TO MATE WITH THE ANEROID SEAR AND INITIATE FIRING AT A PRESCRIBED ALTITUDE. A ROUGH OR SCRATCHED LOCKING ASSEMBLY MAY CAUSE A HANGUP DURING THE UNLOCKING FUNCTION.

NOTE: Ripcord release assemblies with part number 711-07022-30 (10,000-foot) must fire at 10,000 feet (plus or minus 1,000 feet) pressure altitude. Ripcord release assemblies with part number 711-07022-34 (14,000-foot) must fire at 14,000 feet (plus or minus 1,000 feet) pressure altitude.

10. Three firing altitude checks must be made. Any ripcord release that does not meet test requirements on all three checks will be rejected. Adjustments are not to be made.

11. Remove the dummy cartridge and inspect it for an indentation caused by the hammer firing pin striking the cartridge. This dent must be visible to the QA performing the inspection.

ARMING AND ASSEMBLING THE AUTOMATIC PARACHUTE RIPCORD RELEASE

The following instructions are the same type you will follow in the shop when arming and assembling the Model 7000 ripcord release. When you use the NAVAIR 13-1-6.2 manual and come to a step that is followed by "(QA)," that step must be inspected by a QA.

1. To arm the ripcord release that is installed in a parachute, your first step is to insert the arming cable housing through the holes in the parachute container and ripcord release pocket.

2. Next, feed the arming cable through the arming cable housing. Depending on application, the arming cable may be inserted at either side of receiver and barrel assembly (fig. 2-11).

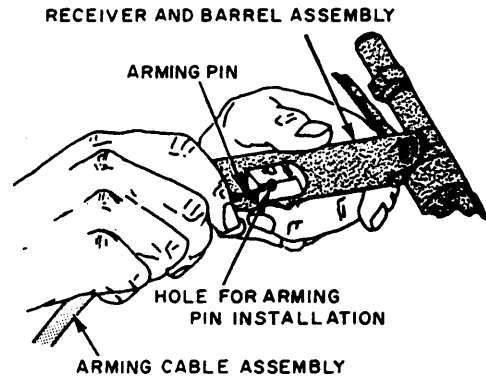

239.230

Figure 2-11.—Installing an arming cable.

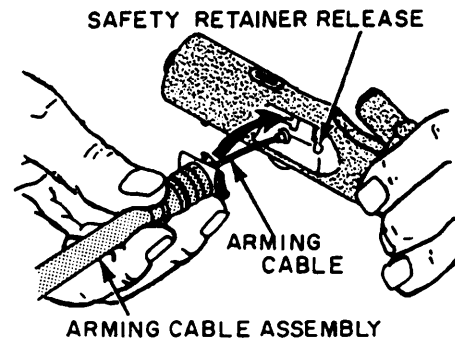

239.231

Figure 2-12.—Installing an arming cable housing.

3. With the ripcord release barrel in the open position, install the arming pin into the ripcord release. The pin must pass through the hole in the side of the receiver, through the firing mechanism lock, and out the opposite side of the receiver.

4. Next, you connect the arming cable housing to the receiver and barrel assembly. Ensure the safety retainer secures the housing to the receiver (fig. 2-12). Be sure that you check the cartridge service life at this time. You should not install a cartridge that will expire prior to the next scheduled repack of the assembly. Refer to NAVAIR 11-100-1 for the service/total life of cartridges.

5. You should enter the cartridge time delay, part number, type, expiration date, lot number, can open/installation date, the CAD DODIC (Department of Defense Identification Code), and the date of manufacture or overhaul on the parachute Configuration, Inspection, and History Record.

6. Insert a proper time-delay cartridge in the barrel. Refer to the applicable parachute chapter to determine which time-delay cartridge should be used. While you are pressing down on the barrel, look through the inspection hole in the receiver and ensure that the hammer assembly does not swing towards the firewall. If the hammer swings, the arming pin is improperly installed. Do not attempt to assemble the ripcord release any further, as this could fire the cartridge.

7. Press the barrel down into position in the receiver (fig. 2-10). As the barrel reaches proper position, exert forward pressure on the snap lock. This causes the snap lock pins to lock the barrel in position. Ensure that the snap lock is aligned with the alignment arrow.

8. Hold the ripcord release, as shown in figure 2-13, and slide the receiver and barrel assembly into the cover and power cable assembly until the holes for the screw are aligned.

9. Install the locking screw and lock washer. Apply a tamper dot to the locking screw, using red lacquer.

CHECKOUT OF ARMED RIPCORD RELEASE

To check out an armed automatic ripcord release, you should proceed as follows:

1. Check the arming cable for proper installation, as shown in figure 2-14. The arming pin must be visible (extending through the side of the receiver).

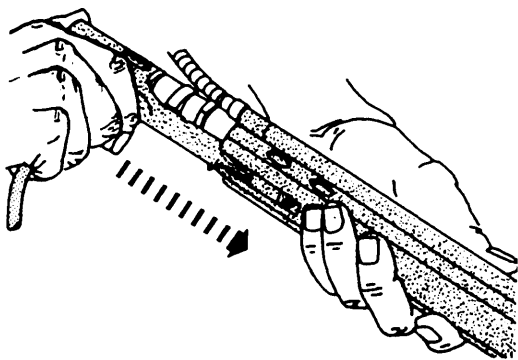

239.232

Figure 2-13.—Sliding receiver and barrel into cover assembly.

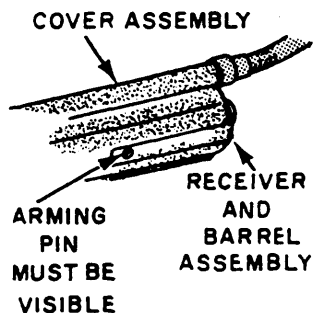

239.234

Figure 2-14.—Checking arming pin for proper installation.

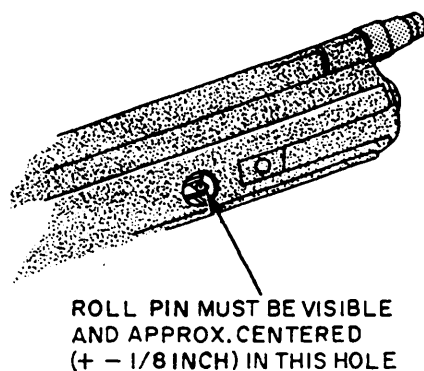

239.235

Figure 2-15.—Checking roll pin.

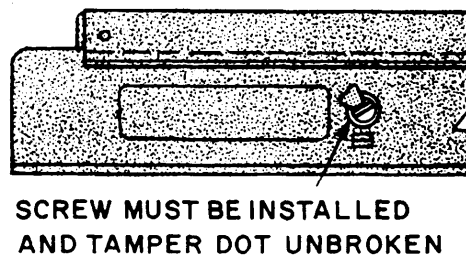

239.233

Figure 2-16.—Checking lock screw.

2. Check for correct position of the spring and centering of roll pin in hole (fig. 2-15).

3. Check to make sure the locking screw is installed. Be sure that the tamper dot isn't broken (fig. 2-16).

4. Check for proper position of the aneroid (fig. 2-17).

5. The cartridge must be installed (fig. 2-18). Look through the port and verify that the cartridge is installed.

6. Complete the ripcord release installation in accordance with the applicable parachute chapter in NAVAIR 13-1-6.2.

To install an automatic parachute ripcord release, you must refer to the *Emergency Personnel and Drogue Parachute Systems Manual*, NAVAIR 13-1-6.2.

BALLISTIC SPREADING GUN ASSEMBLY

The ballistic spreading gun is a mechanically actuated device that ensures rapid inflation of the

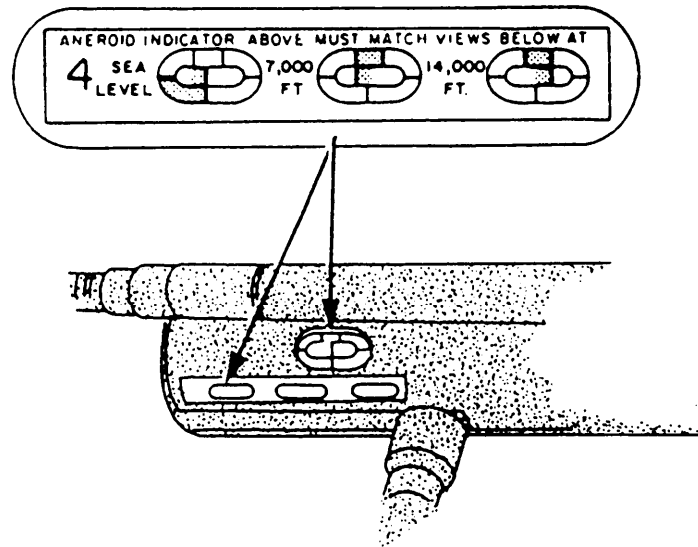

Figure 2-17.—Checking for proper position of aneroid.

239.236

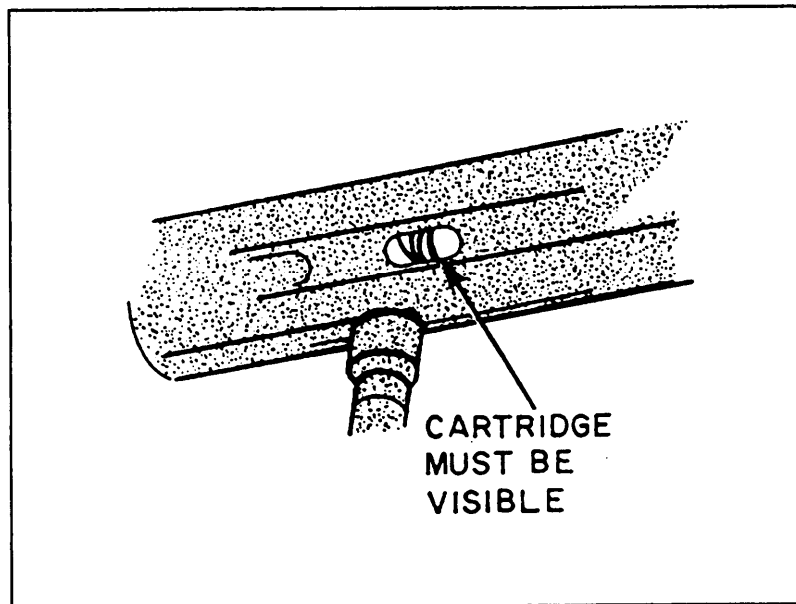

Figure 2-18.—Checking for cartridge.

239.237

main parachute canopy, and it reduces random inflation time of the canopy during high-speed ejections (figs. 2-19 and 2-20).

DESCRIPTION

The spreader gun assembly consists of a spreader housing, 14 pistons, slugs, and retainers, an impulse cartridge, a fail-safe mechanism, and a hardware retention lanyard.

The spreader gun is provided with a fail-safe assembly in the event of a cartridge malfunction. The fail-safe assembly consists of a nylon sleeve clipped to the shear band assembly.

A safety pin is inserted in the firing mechanism during handling to prevent accidental firing. The cartridge for the spreader gun is threaded into the breech of the housing and has a retention cord attached. The spreader gun is positioned at the hem of the main parachute between the retaining cord and lower firing lanyards.

The retaining cord is looped around the vent lines and the pilot parachute connector cord.

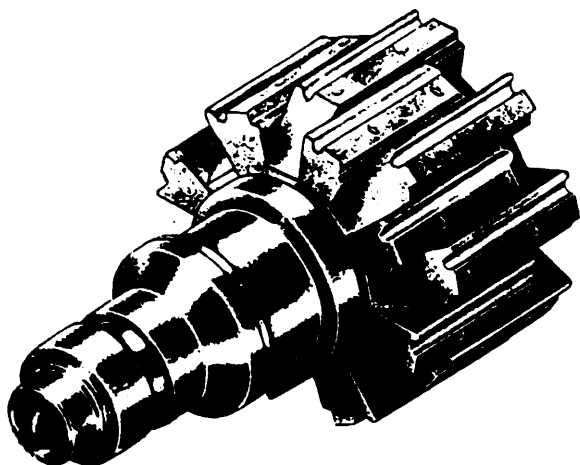

239.466

Figure 2-19.—Spreading gun assembly.

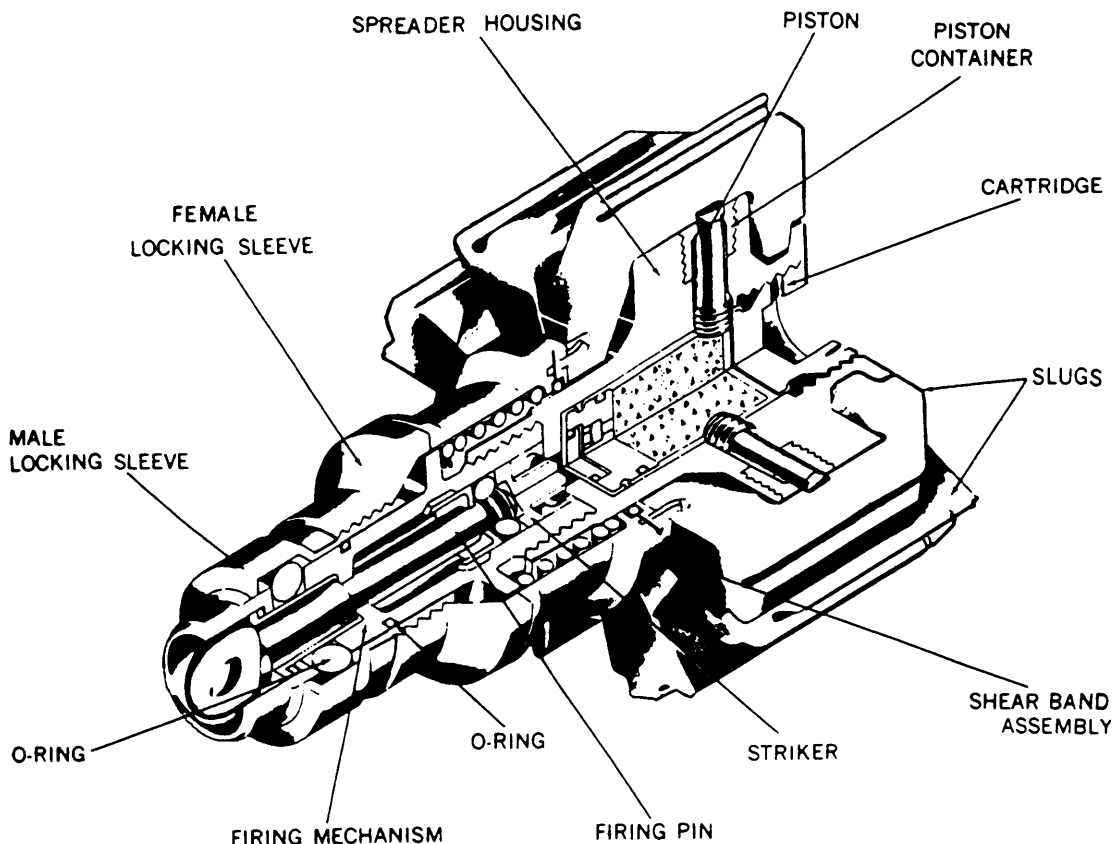

Figure 2-20.—Spreading gun assembly parts breakdown.

The lower firing lanyard is attached to the connector link next to the suspension lines. Two suspension lines and a loop from the parachute hem are attached to each slug. A cover plate holds the two lines and loop in the channels of each slug.

OPERATION

When actuated, the parachute canopy deploys by either an internal pilot chute or by the external pilot chute. Just prior to full canopy and suspension line deployment, the firing lanyard pulls the firing pin from the firing mechanism. This releases the striker, which strikes the cartridge primer. As the cartridge fires, the 14 slugs are propelled outward. They simultaneously drag the attached suspension lines outward in a 360-degree spread. This firing sequence occurs prior to any tension being placed on the suspension lines. Spreading is stopped when tension starts to build up in the suspension lines; so, at high speed it produces a 4-foot diameter mouth, and at low speed, it produces an 8-foot diameter mouth.

In the event of a cartridge malfunction, a "fail-safe" backup subsystem operates. After the firing pin is withdrawn, the firing lanyard exerts 25 to 38 pounds of tension on the fail-safe assembly sleeve, which retracts the shear band assembly. This releases the slugs and allows the canopy to inflate aerodynamically.

IDENTIFICATION AND HANDLING

An identification tag is attached to the spreader gun and contains the following data: nomenclature, manufacturer's part number, revision status, serial number, date of manufacture, and name and address of the manufacturer.

A warning label is sewn on each side of the sleeve protecting the firing lanyard and to the outer pack assembly. This label reads as follows:

WARNING

THIS PARACHUTE CONTAINS A CARTRIDGE ACTUATED DEVICE. FOR HANDLING INSTRUCTIONS SEE PARACHUTE PACKING MANUAL.

There is a tag attached to the safety pin that reads: "REMOVE PIN BEFORE PACKING." Assemblies shipped without a cartridge must have a shipping plug installed.

Service Life

Refer to NAVAIR 11-100-1-1 for the shelf/installed life of the spreading gun cartridge. The service life expiration date (month and year) is marked with indelible ink on the side of each cartridge.

NOTE: If the date the sealed container was opened is not available, the INSTALLED LIFE is computed from the date of manufacture as determined from the lot number.

Log Entries

You should enter on the Parachute History and Record Card the date of primary installation of the spreader gun to the parachute canopy, the lot number, expiration date, part number, CAD DODIC, and date of manufacture or overhaul of the cartridge.

Safety Precautions

Treat the spreader gun as a delicate instrument. The spreader gun cartridge is treated as class C ammunition in accordance with the general safety precautions given in the cartridge manual (NAVAIR 11-100-1.1).

WARNING

YOU MUST ALWAYS REMEMBER THAT THE BALLISTIC SPREADING GUN IS LETHAL WHEN ACTIVATED WITHOUT A CANOPY ATTACHED. DO NOT REMOVE THE SAFETY PIN UNTIL THE PROPER TIME AS PRESCRIBED IN THE PACKING MANUAL.

DO NOT REMOVE LANYARD RETAINING PIN WHEN REPLACING UPPER RETAINING CORD.

NOTE: Be sure that the cartridge service life will not expire prior to the next service check. Be sure the cartridge expiration date is entered in the Parachute History and Record Card.

REMOVAL OF BALLISTIC SPREADING GUN

Before you work on a spreader gun, always ensure that a safety pin is installed. If you have to remove a damaged or defective spreading gun, proceed as follows:

1. Loosen the screws holding the plates to the spreading gun slugs to allow suspension lines to be removed.
2. Slip all the suspension lines and attached loops from under the plates.
3. Disconnect the retaining cord from the vent lines.
4. Tie one end of a temporary 20-foot line to the vent lines, and tie its other end to the free end of the retaining cord.
5. Pull the retaining cord out of the canopy from the skirt end.
6. Untie the temporary 20-foot line from the retaining cord, and remove the damaged or defective gun from the table.
7. To install a new or repaired spreading gun, follow the procedures outlined in the applicable parachute assembly chapter in the *Emergency Personnel and Drogue Parachute Systems Manual*, NAVAIR 13-1-6.2.

BALLISTIC SPREADING GUN CARTRIDGE REPLACEMENT AND PULL-FORCE CHECK

WARNING

BEFORE YOU ATTEMPT TO REPLACE A CARTRIDGE, YOU MUST REMEMBER THE SPREADING GUN EMPLOYS AN EXPLOSIVE CARTRIDGE. FAILURE TO OBSERVE PROPER PROCEDURES COULD RESULT IN SERIOUS INJURY OR DEATH.

NOTE: You must use only the special tools furnished for cartridge removal or replacement. It is recommended that a helper assist you in performing the cartridge replacement by verifying procedures as each step is accomplished. You must perform a firing pin pull-force check each time you replace a cartridge.

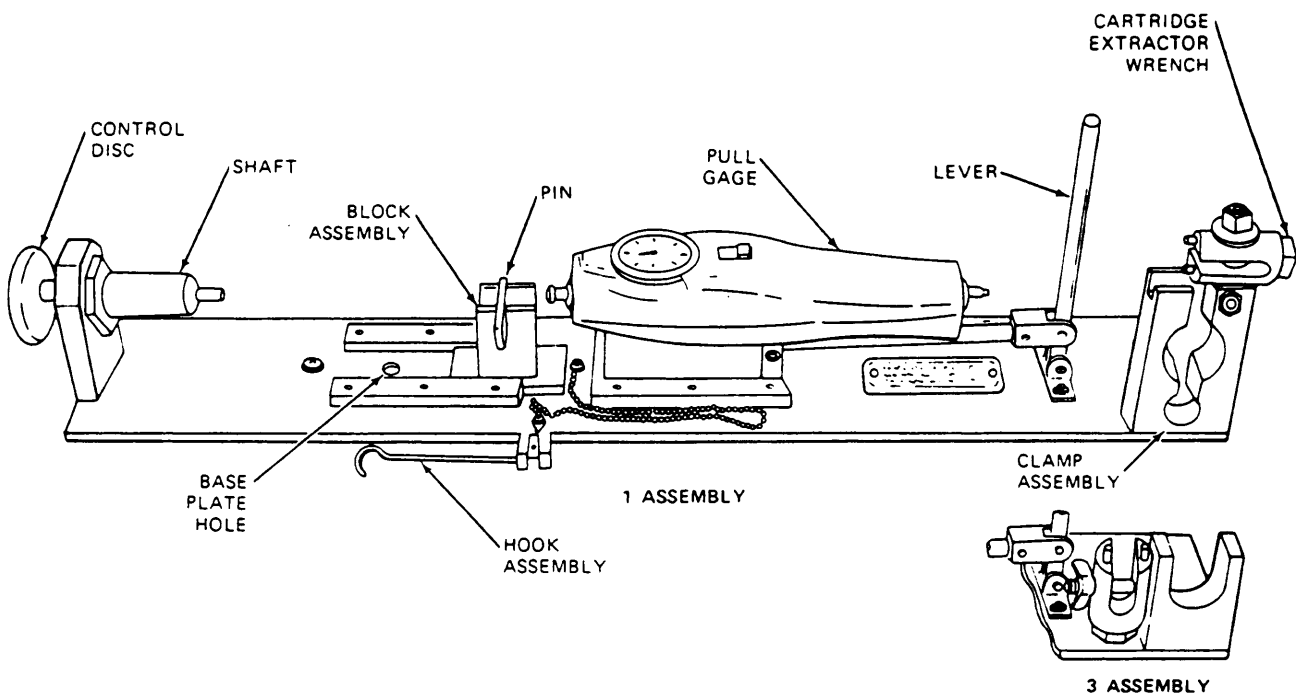

Figure 2-21.—Spreading gun test fixture.

239.117

By following the steps outlined below, you can replace the cartridge and perform the firing pin pull-force test in a safe manner.

1. Clamp the spreading gun test fixture to the packing table. Use one C-clamp positioned as close as possible to the clamp assembly. See figure 2-21 for the test fixture parts identification.

2. You must remove the cartridge extractor wrench from the swivel bolt attached to the spreading gun clamp assembly.

3. Then place the cartridge end of the spreading gun into a spreading gun clamp assembly (fig. 2-22). Ensure that the lip on the clamp assembly circles the spreading gun housing. Route the retaining cord through the vertical slot in the center of the clamp and spread suspension lines to prevent entrapment between gun and clamp. Position the swivel bolt in the horizontal slot in the clamp, and torque the swivel bolt nut to $7 \pm 1/2$ foot-pounds.

4. Place the pins of the cartridge extractor wrench into holes in the cartridge. Loosen the cartridge using pressure against a 3/4-inch socket, as shown in figure 2-23.

NOTE: If you have difficulty in removing the cartridge by using the extractor wrench furnished with the test fixture, use a special cartridge extractor tool. Cut and remove the retaining cord at the base of the cartridge. Place the slot of the special tool over the retaining cord pin, and loosen the cartridge by using a 1/2-inch socket.

5. Remove the spreading gun from the clamp or V-block assembly. Manually unscrew and remove the cartridge from the chamber.

6. Remove the cartridge from the retaining cord by removing the pin. Retain the pin for reinstallation if required. The old cartridge must be disposed of in accordance with current directives.

7. Remove the safety pin from the spreading gun.

8. Spread the canopy skirt hem and suspension lines to expose the cartridge chamber. Slide the spreading gun onto the test fixture shaft

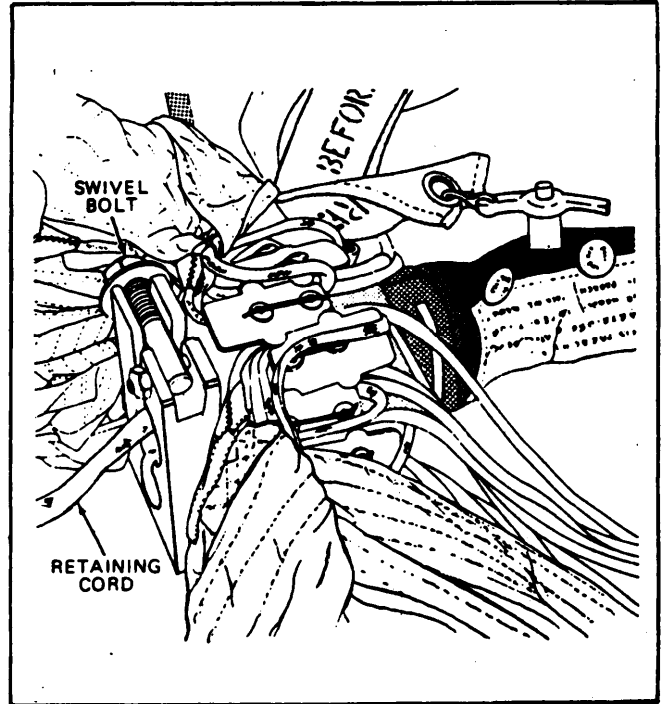

Figure 2-22.—Placing spreader gun in gun clamp.

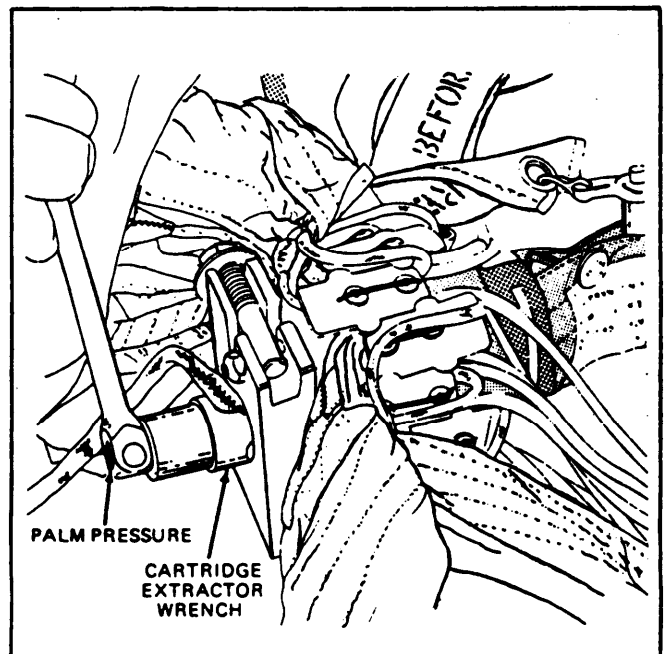

Figure 2-23.—Loosening cartridge.

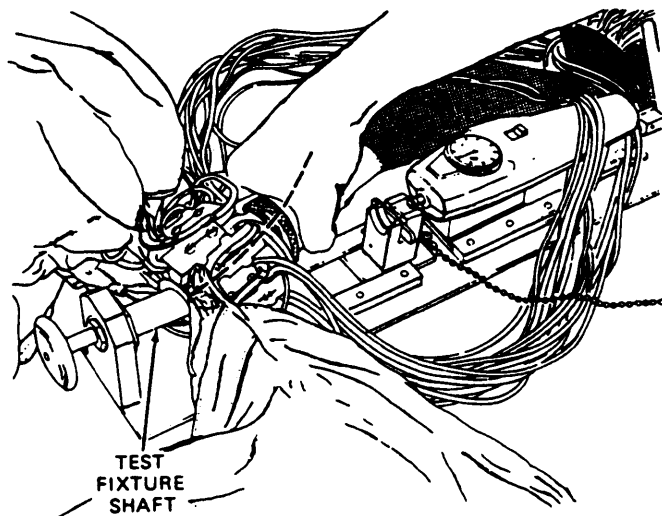

Figure 22-24.—Sliding on to test fixture.

so that the shaft butts against the bottom of the cartridge chamber (fig. 2-24).

9. Open the four snap fasteners on the spreading gun extractor sleeve to expose the firing pin housing. Slide the block assembly at the center of the test fixture under the firing pin housing until the block assembly pin slides into the baseplate hole. Align the firing pin so that the hole in the firing pin is horizontal. The firing lanyard is located at the top. (See figure 2-25.)

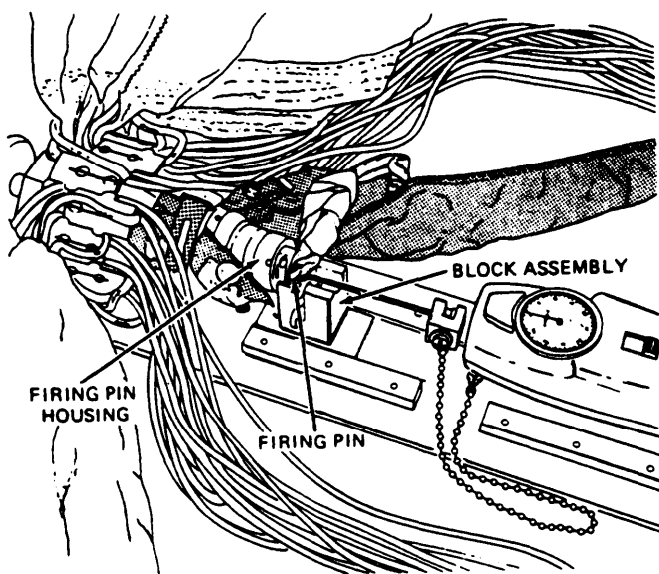

Figure 2-25.—Spreading gun installation.

10. Attach the hook assembly to the firing pin hole, and slide the hook assembly block over the nut that is attached to the pull gage. (See figure 2-21).

11. Move the switch on the pull gage to the center position. You must zero your meter needle by rotating the bezel on the dial. Move the switch to the full down position, away from the meter, for recording the pull force.

12. The QA verifies the test fixture lever firing pin releases. The pull force must go between 25 and 38 pounds. If a gun has failed the first test, it must be retested two more times. The gun must pass both retests. Record the force required to release the firing pin on the Parachute Configuration, Inspection, and History Record. When a gun fails, it is removed and returned to supply as a defective item.

13. After the pull-force measurement has been obtained, remove the hook assembly from the firing gun.

14. Push the firing pin back into the housing. Push the control disc firmly inward, forcing the firing pin out of the housing. Apply inward hand pressure to the firing pin as it moves out. Continue to move the control disc inward, applying hand pressure to the firing pin until it clicks into place. When a click is heard, the gun is cocked. Gently release the control disc while still exerting pressure on the pin.

15. The QA inspector must tug gently on the firing pin until the effect of spring loading is felt. If the pin moves without spring tension, the gun is not cocked, and step 14 must be repeated.

16. Release the block assembly by pulling the pin out of the hole in the baseplate and sliding the block away from the spreading gun. Remove the gun from the shaft. Do not remove the gun by pulling on the firing lanyard.

17. At this time, install the safety pin.

CAUTION

WHEN YOU ARE USING ALCOHOL TO CLEAN THE CARTRIDGE CHAMBER, DO NOT ALLOW ALCOHOL TO FLOW INSIDE THE GUN BECAUSE THIS COULD DAMAGE THE O-RINGS AND LUBRICATION.

18. Clean the cartridge chamber and threads with a small amount of denatured alcohol. Ensure that the old sealing compound and all foreign matter is removed. Tilt the gun to allow the alcohol to run out of the gun.

19. Feel the inside of the cartridge chamber to ensure that the slug pistons do not stick out inside the chamber. If the pistons do protrude, push them back as necessary. Feel the bottom of the chamber to ensure there is no foreign object in the chamber. The bottom should be smooth metal.

20. Prior to the cartridge installation, stamp on the cartridge, in the approximate position shown in figure 2-26, the following information: lot number, manufacturer's symbol, month and year of loading. Use black marking ink and make the characters as large as practicable for the available space. The same markings, plus expiration date and the can open date, must also be stamped on the cartridge head, using characters no smaller than 1/16 inch high.

21. Record the type of cartridge, part number, delay time, lot number, and service life expiration date on the Parachute Configuration, Inspection, and History Record.

22. Apply sealing compound to the top two threads of the cartridge. (See figure 2-26.)

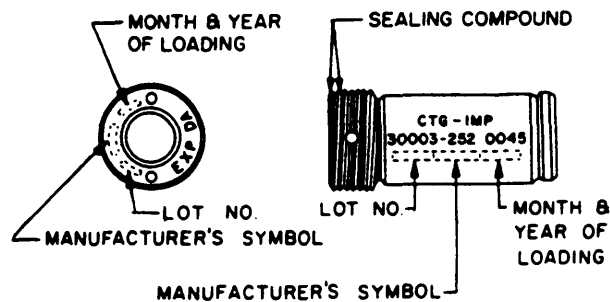

Figure 2-26.-Cartridge markings-head and side.

23. Attach the new cartridge to the retaining cord by passing the pin through the screw base of the cartridge and the loop that is located at the end of the retaining cord.

NOTE: Never force the cartridge into the chamber. This could damage the gun. When a cartridge is properly installed, the base should be approximately even with the top edge of the chamber. If the cartridge base is more than one thread above the edge, remove the cartridge and check the bottom of the chamber for any obstruction, such as protruding slug pistons.

24. Having inserted the cartridge into the chamber, you tighten it manually. If the cartridge stops before the threads are engaged, remove the cartridge and again check for protruding slug pistons. Push them back if necessary.

25. Replace the gun in the clamp or V-block assembly in accordance with steps 3 and 4. Using a cartridge extractor wrench and torque wrench with a 3/4-inch socket, you must torque the cartridge to 84 inch-pounds (plus or minus 12 inch-pounds).

26. Remove the spreading gun from the clamp or V-block assembly. Do not remove the safety pin. Put the cartridge extractor wrench back on the swivel/stanchion bolt.

27. Check stowage of the firing lanyard. Restow it if necessary.

28. Close the extractor sleeve. Now your job has been completed.

To install a ballistic spreader gun onto a parachute, you must refer to the *Emergency Personnel and Droge Parachute Systems Manual*, NAVAIR 13-1-6.2. Repacking a parachute with a ballistic spreader gun is discussed in chapter 3 of this manual.

CHAPTER 3

NES-12 PERSONNEL PARACHUTE SYSTEM

Learning Objective: Upon completion of this chapter, you will be able to understand the theory of operation and perform a special inspection on the NES-12 parachute assembly.

The modern high-performance aircraft used by the Navy today make extreme demands of emergency escape devices. The most critical time for ejection from an aircraft is at low altitudes—especially on takeoffs and landings. The ultimate goal in seat performance (to which engineers have been working) is one that safely ejects the occupant at zero airspeed and at zero altitude, at low altitudes under a high speed, or under other adverse altitude conditions. The system discussed in this chapter gives the aircrewman a zero airspeed and a zero altitude ejection system.

The 1G series ejection seats separate from the aircrewman by means of a rocket that forcibly propels the seat away from the crew member after ejection.

After the aircrew member ejects from the aircraft, a static line on the outside of the container pulls the external pilot chute from its pocket. The sequence of events shown in figure 3-1 commences. This static line is also attached to the arming cable for the automatic parachute ripcord release. The external pilot chute is intended to cause the parachute to open more rapidly, especially at low altitudes or during ground-level ejection. It is of a tristage design and functions as follows: At speeds from 0 to 90 knots, it will inflate to full diameter; at speeds between 90 to 250 knots, the full diameter will reduce to 24 inches; and at speeds in excess of 250 knots, it will invert, but its effective drag will be sufficient to stabilize the aircrew member during free fall and also aid in the extraction of the main canopy during deployment.

At a preset altitude, the automatic ripcord release fires, pulling the ripcord pins from the locking cones, allowing the spring opening bands to open the container. The internal pilot parachute springs from the container and fills with air during

this operation. The external pilot chute release assembly frees the shear link cable when the container opens.

The internal pilot parachute causes the main canopy to be pulled from the container, followed by the suspension lines. A short piece of 18-pound nylon tape is used to momentarily shorten the canopy's effective length during low-speed ejection, which, in turn, promotes more positive opening characteristics. Just prior to full suspension line stretch, the ballistic spreading un fires, forcing the suspension lines out at the skirt hem. This rapidly opens the canopy and allows it to fill with air faster. Ties on the connector links break as load is applied, allowing the risers to be pulled from the container.

NOTE: If the spreading gun fails to fire, the slugs separate from the gun assembly at full suspension line stretch, allowing the canopy to open aerodynamically.

The aircrew member hangs suspended in his harness from the quick-release shoulder fittings during descent. The parachute has the four-line release system that was described previously. By manually actuating this system, the aircrewman is able to maneuver the parachute to a less hazardous landing site and to reduce oscillation during descent. Upon landing, the canopy and suspension lines can be disengaged from the integrated torso suit by means of the quick-release shoulder fittings.

NOTE: After the incorporation of Aircrew System Change 446, the seawater activated release system provides an automatic backup method of releasing the risers after the crew member makes a seawater entry.

ESCAPAC 1G-2 SEAT

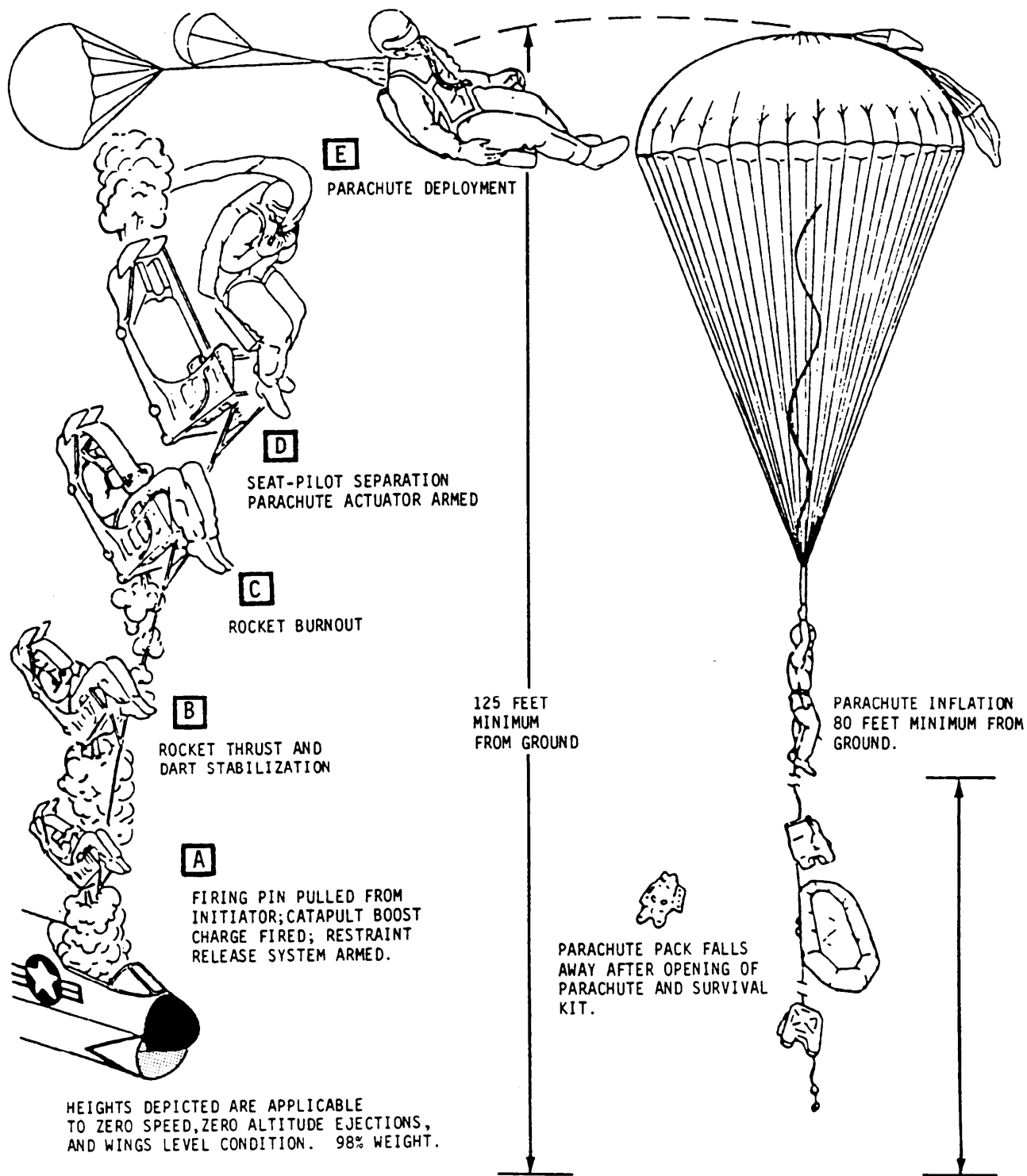

Figure 3-1.—Ejection system sequence of events.

If the aircrew member should have to manually separate from the seat and initiate the parachute operation, only the internal pilot parachute will deploy the main canopy. The external pilot chute bridle is disconnected by

means of the external pilot parachute override disconnect assembly, which is discussed later in this chapter.

The NES-12 personnel parachute (fig. 3-2) is a back-type parachute used with an integrated

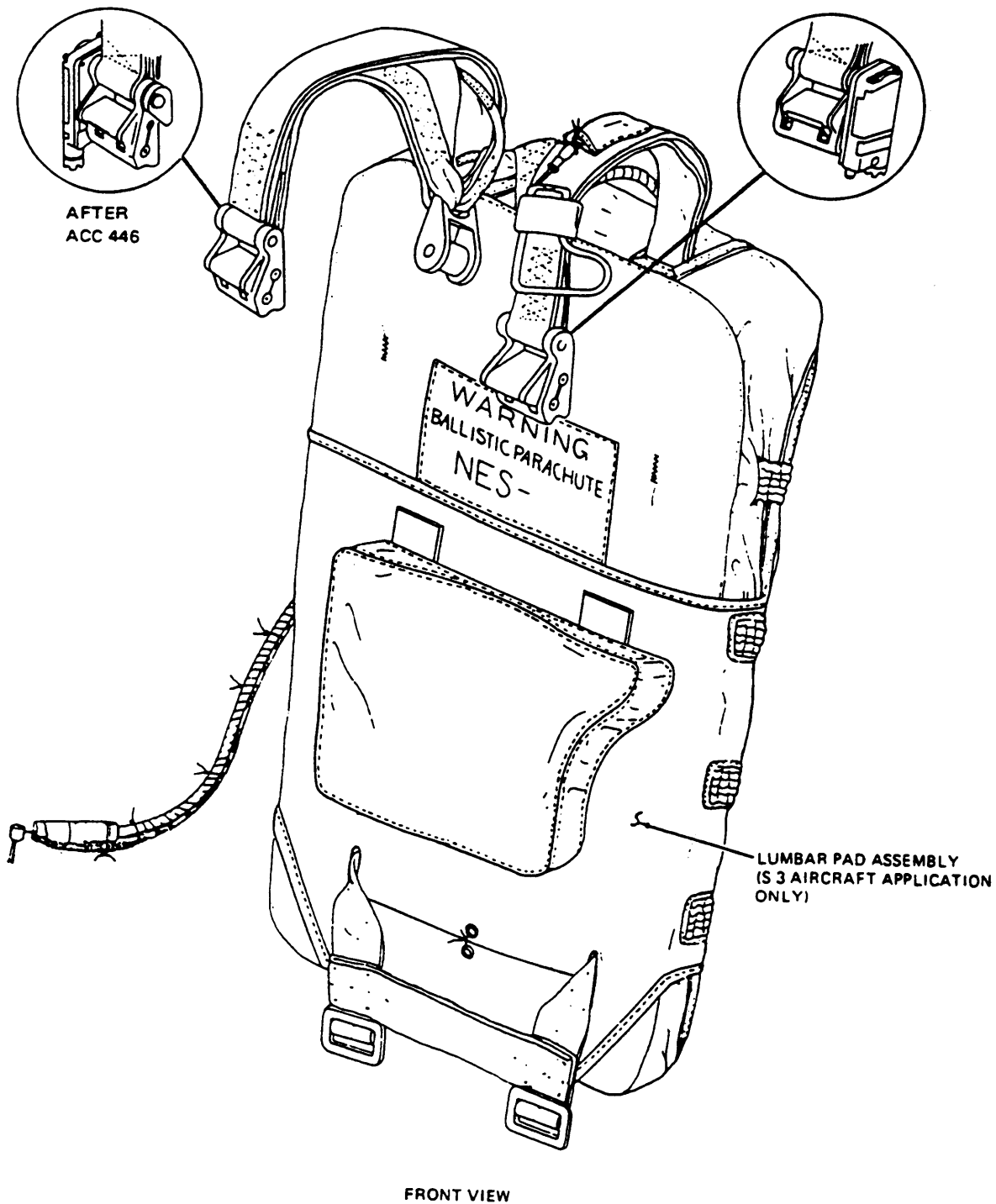

Figure 3-2.—Personnel Parachute Assembly, NES-12.

torso harness suit as part of an ejection seat escape system.

The NES-12 parachute assemblies include a modified 28-foot diameter, flat nylon canopy with 28 gores. A ballistic spreading gun is used to rapidly deploy the canopy. The canopy is packed in a semirigid contoured container. These assemblies also include the tristage external pilot chute (EPC) and an internal pilot chute. The riser assembly, which includes the shoulder restraint system, is rigged to the container and is connected to the torso harness suit with quick-release fittings. The integrated torso harness suit combines the aircrewman's parachute harness and lap and shoulder restraint straps. The harness is channeled through the torso suit to retain it in position and to aid in donning. When aboard the aircraft and seated, the aircrewman connects the quick-release fittings on the parachute riser assembly to the quick-release fittings on the parachute integrated torso suit. The survival kit and the lap restraint system are also connected to the integrated torso suit by means of quick-release fittings.

RIGGING

To obtain the NES-12 parachute, you order each component separately. You must rig the parts together to form a complete assembly. When you start to work on this or any parachute, the rigging and packing will be done under ideal conditions in a parachute loft. When a parachute assembly must be packed under unfavorable conditions, provisions must be made to protect it from possible damage and excessive humidity. Quality assurance (QA) points are included in rigging and packing procedures. When a step is followed by "(QA)," it is a QA requirement. All work STOPS until a quality assurance inspector performs the requirements listed at the end of the applicable procedure.

The packing of a parachute assembly must NOT be interrupted after the packing operation has been started. If unforeseen circumstances cause the packing operation to be interrupted, the parachute assembly must be completely repacked.

The rigging covered in this chapter applies to an original issue parachute assembly.

NOTE: This rate training manual is not to be used as a substitute for the NAVAIR 13-1-6.2 or the NAVAIR 13-600-4-6-3 manuals.

PRELIMINARY PROCEDURES

After you have laid out the parachute and connected the connector links to the proper tension hooks, attach the internal pilot parachute. This is done by routing the small loop of the bridle assembly through the loop in the pilot parachute. Pass the free end (large loop) of the bridle assembly through the small loop, forming a lark's head knot. Draw it tight. Pass one free end (large loop) of the bridle assembly around the canopy vent lines at the peak of the canopy. Pass the pilot parachute through the large loop of the bridle assembly, forming a lark's head knot, and draw tight. Now, attach a tension strap to the canopy vent lines and tighten it.

At this time, you should inspect the complete parachute assembly following the directions in NAVAIR 13-1-6.2 and NAVAIR 13-600-4-6-3. This inspection has been covered in chapter 1 of this manual.

INSTALLATION OF SPREADING GUN

A ballistic spreading gun (fig. 3-3) is used in the parachute. The procedures for inspecting this device was discussed in chapter 2. After the parachute has been inspected and

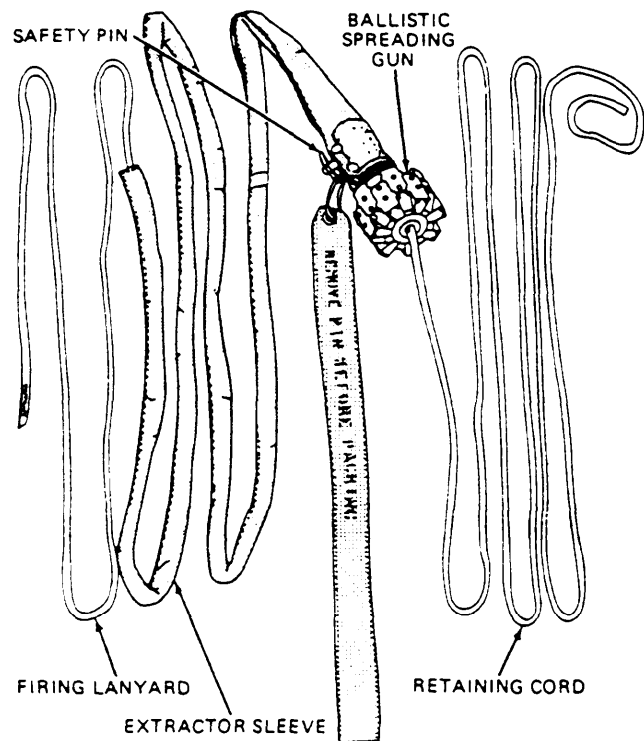

Figure 3-3.—Ballistic spreading gun assembly.

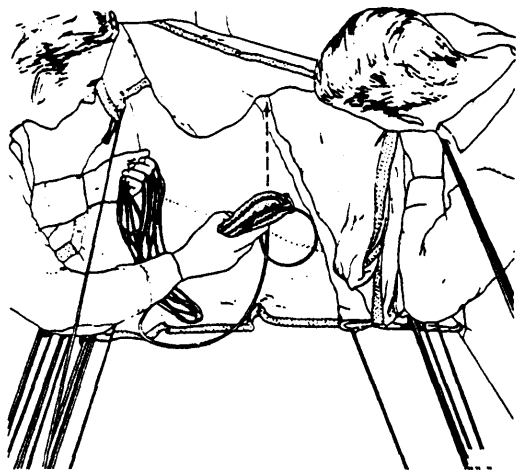

Figure 3-4.—Routing line for pulling retaining cord through canopy.

rigged, install the spreading gun using the following procedures:

WARNING

BEFORE COMMENCING ANY FURTHER OPERATIONS, ENSURE THAT THE SAFETY-PIN IS INSTALLED IN THE SPREADING GUN.

Tie a piece of Type III nylon suspension line 20 feet long to a shot bag (fig. 3-4).

Throw the shot bag attached to the line through the canopy gores so that it reaches the canopy peak. Then pull the shot bag through the vent hem and tie the line temporarily to the vent lines. Secure the bottom end of this line to keep it in place while you whip and fold the canopy. When the canopy has been whipped and folded, tie the free end of this line to the end of the spreading gun retaining cord and pull the retaining cord through the canopy and out the peak.

Untie the Type III nylon line from the retaining cord and vent lines, and route the retaining cord through the lark's head knot in the pilot parachute connector strap and under all the vent lines. The retaining cord has a plastic sleeve that should be centered over the indexing line on the retaining cord. Align the indexing line on the retaining cord above the vent lines.

With the help of a bodkin tool, telescope 2 inches of the retaining cord into itself to form a

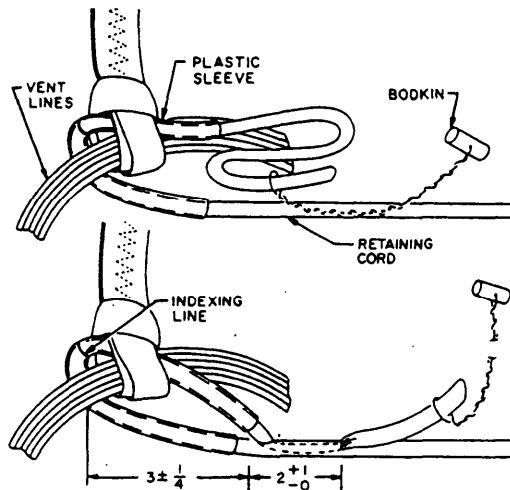

Figure 3-5.—Rigging retaining cord.

3-inch loop ($\pm 1/4$ inch) around the vent lines and connector strap, as shown in figure 3-5. Cut 1 inch off the end of the retaining cord at a 45-degree angle.

Tie a half-hitch around the retaining cord and complete the splice by telescoping the remainder of the end into the retaining cord, as shown in figure 3-6. Work the line until it becomes smooth on the inside of its casing.

Tack the end inside the retaining cord with two turns of waxed nylon 6-cord, doubled. Tie the ends with a surgeon's knot followed by a square knot.

Now position the spreading gun at the skirt hem. Place the spreading gun between the suspension line groups 1 through 14 and 15 through 28 so the retaining cord of the gun faces the canopy peak. Remove the tension strap from the canopy peak.

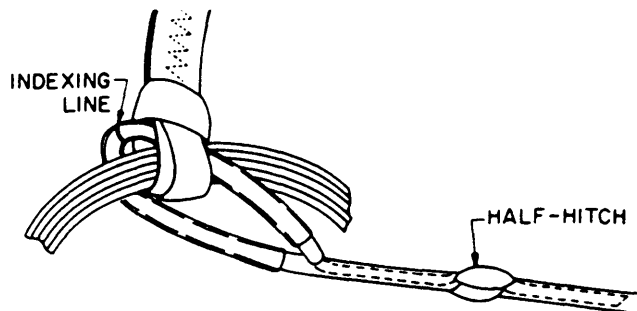

Figure 3-6.—Rigging retaining cord (completed splice).

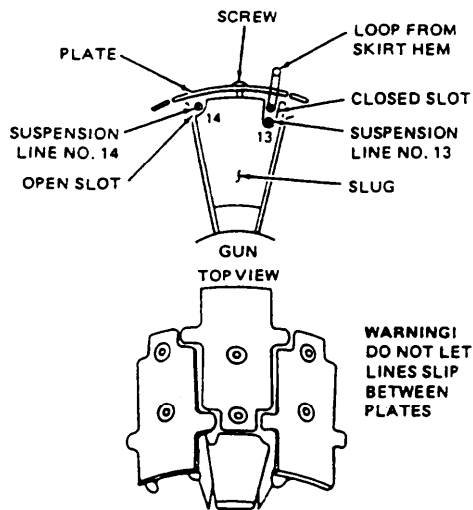

Figure 3-7.—Attachment of spreading gun to suspension lines.

Rotate the gun so the slug labeled “14-13” is facing up, and loosen the screws and plate on this slug. You will find two slots on the face of each slug. One is “closed” or covered when the plate is in place. The other is open to the side of the slug (fig. 3-7). Place suspension line number 13 and one side of the loop of line attached to the canopy hem in the closed slot of the slug (fig. 3-8). Place suspension line 14 in the open slot of the same slug.

Pass the loop around the plate and over the suspension line in the slug. Secure the plate to the slug with screws and ensure the suspension lines move freely in the slots. Torque the plate screws to 6 (plus or minus 1/2) pound-inches and apply red tamper dot.

Secure the remainder of the suspension lines and loops to corresponding slugs in the same manner. Work from suspension line 12 through 1 and from line 15 through 28 (fig. 3-9).

After the above procedures are completed, you must have a QA inspect the completed installation of the spreading gun.

THE EXTERNAL PILOT PARACHUTE

A special feature of the NES-12 parachute is the external pilot parachute. To function properly,

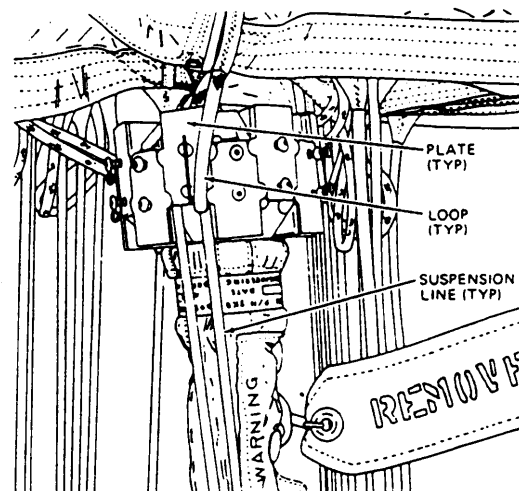

Figure 3-8.—Installing suspension lines.

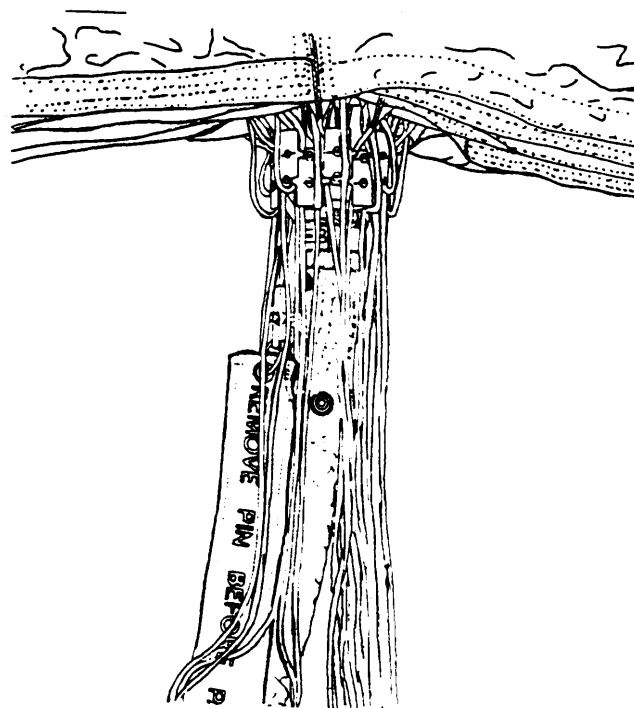

Figure 3-9.—Complete set of suspension lines.

the external parachute is connected to the cord that links the internal pilot chute to the main canopy vent lines. A special device is used to jettison the external chute at high speeds. This device is the override disconnect assembly, shown

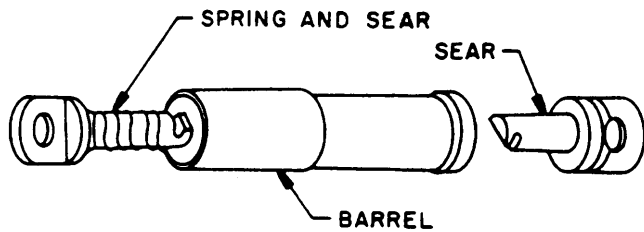

Figure 3-10.—Override disconnect.

in figure 3-10. It consists of two hooks or sears that are kept in engagement as long as they are inside the barrel.

As long as tension is applied to the external pilot chute connection, the override will remain locked. Once the internal pilot chute takes control of the tension, the override connection will release or unlock, allowing the external pilot chute to be released.

To attach the external pilot parachute, proceed as follows:

1. Insert the spring and sear (fig. 3-10) into the wide end of the barrel assembly of the override disconnect. The spring and sear will be connected to the external pilot chute bridle, as shown in figure 3-11. With the aid of a temporary locking

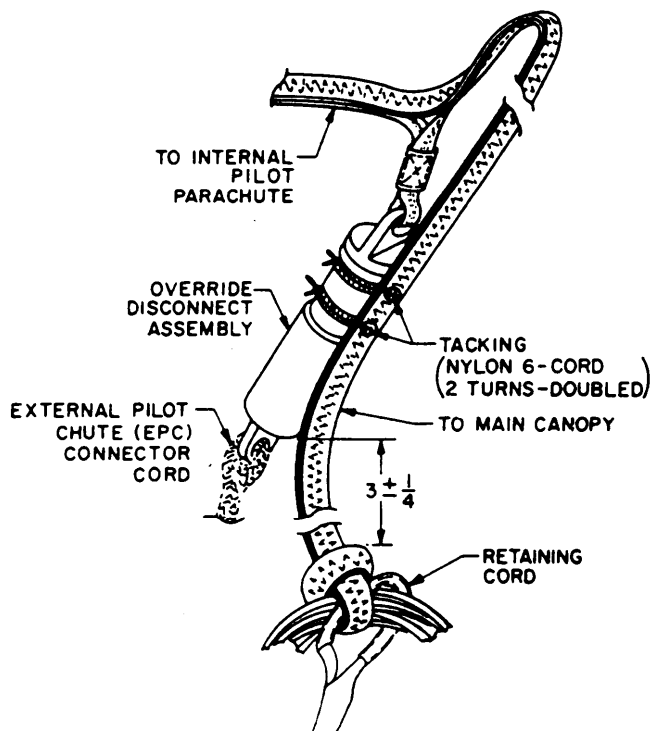

Figure 3-11.—Tacking override disconnects.

pin, push the sear into the barrel until it is protruding from the other end.

2. Engage the sear attached to the internal pilot chute connector cord with the sear, which is protruding from the override disconnect, and release the tension by removing the temporary locking pin. This will cause the two sears to lock within the barrel assembly of the override disconnect. As you can see in figure 3-11, the external and internal pilot chutes are now locked together.

3. Tack the override disconnect to the internal pilot parachute connector strap 3 inches (plus or minus 1/4 inch) above the knot, securing the connector strap to the vent lines at two places. Use two turns of waxed nylon 6-cord (V-T0295), doubled, for each tacking. Tie the ends with a surgeon's knot followed by a square knot.

SUSPENSION LINE CONTINUITY CHECK WITH SPREADING GUN INSTALLED

Although you have checked the continuity of suspension lines prior to installing the spreader gun, they must be checked again to ensure that you haven't gotten any lines out of sequence or have crossed a line causing a twist. To check suspension lines continuity, proceed as follows:

WARNING

ENSURE THE SAFETY PIN IS INSTALLED IN THE SPREADING GUN (FIG. 3-12).

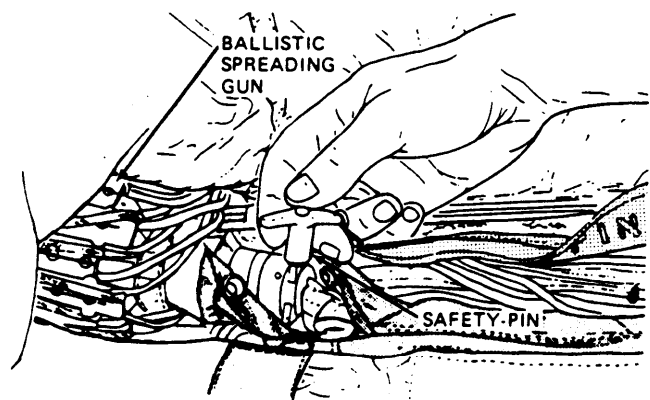

Figure 3-12.—Inserting safety pins.

21 20 19 18 17 16 15 14 13 12 11 10 9 8

22 23 24 25 26 27 28 1 2 3 4 5 6 7

Figure 3-13.—Arrangement of suspension lines on connector links.

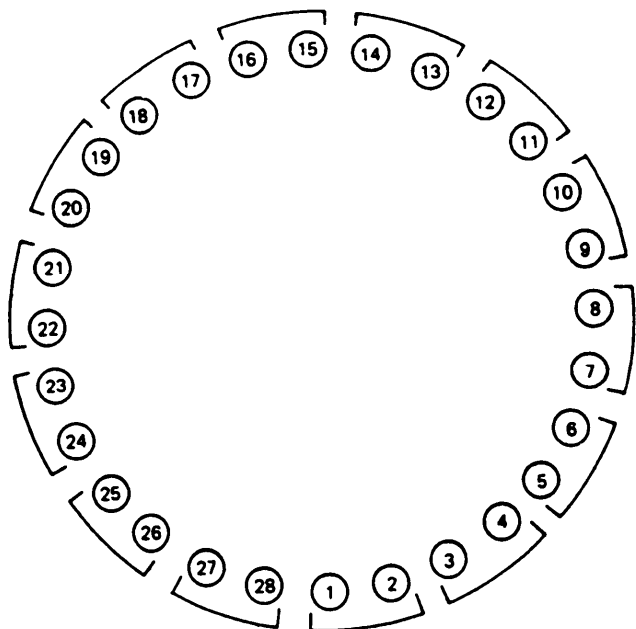

Figure 3-14.—Arrangement of suspension lines on spreading gun.

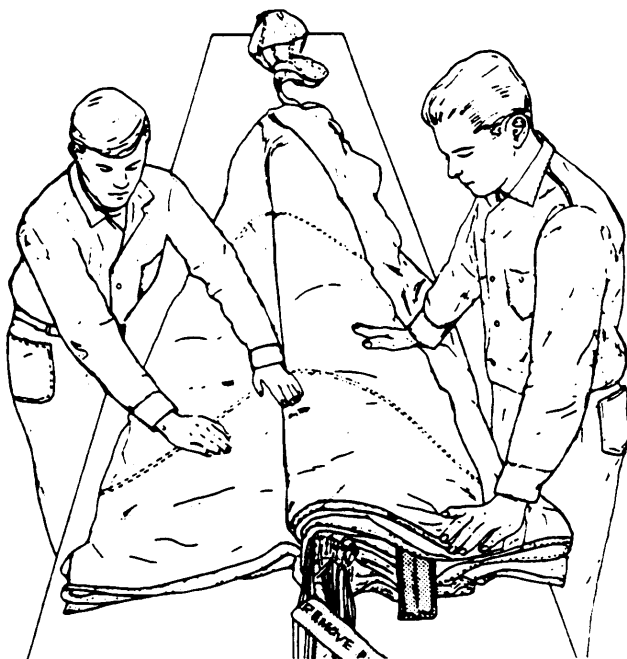

Figure 3-15.—Straightening canopy gores.

- If the canopy isn't already under tension, attach a tension strap hook to the canopy vent lines and tighten.

- The suspension line must be arranged on the connector links, as shown in figure 3-13, and on the spreader gun, as shown in figure 3-14. The spreader guns must be turned so that suspension lines 15 and 14 face up. The suspension lines must pass through corresponding numbered slots in the spreading gun slugs. Ensure that the loops attached to the odd numbered suspension lines pass through the slots in the odd number of slugs.

- Suspension lines must run free from the skirt hem, through the corresponding numbered slot in the spreading gun slugs, and to the connector links without any dips or twists.

STRAIGHTENING CANOPY GORES WITH SPREADER GUN INSTALLED

It would be impossible for you to whip and fold a canopy with a spreading gun installed. For this reason you will have to straighten the gores instead of whipping and folding. Always ensure the safety pin is installed in the spreading gun and the spreading gun firing lanyard is detached from the connector link.

1. The helper should place a shot bag on the helper's side of the skirt hem.
2. The packer rotates all gores on the packer's side as a group, except the bottom gore; it goes over to the helper's side of the packing table. The packer straightens and smooths the bottom gore on the packer's side of the table throughout its length to the peak.
3. The packer returns each gore above the shot bag on the helper's side of the packing table to the packer's side, one at a time. Each fold is straightened and smoothed, as shown in figure 3-15.
4. The folded gores on the helper's side should be straightened and smoothed in the same manner.

STOWAGE OF FIRING LANYARD INTO EXTRACTOR SLEEVE

In stowing the firing lanyard into the extractor sleeve, you must first remember not to remove the spreading gun safety pin at any time during this procedure.

Now you open the extractor sleeve fasteners on each side of the spreading gun safety pin; release the fastener holding the stowage sleeve to the extractor sleeve; and remove the stowage sleeve from the extractor sleeve, as shown in

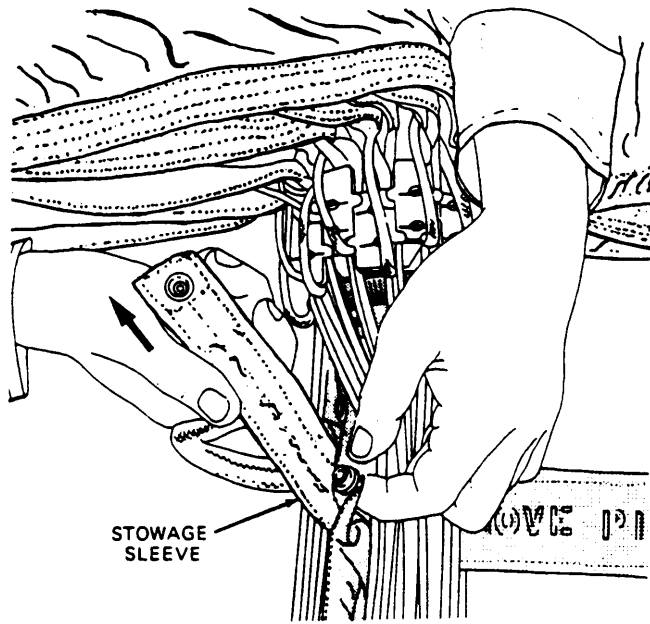

Figure 3-16.—Removing stowage sleeve.

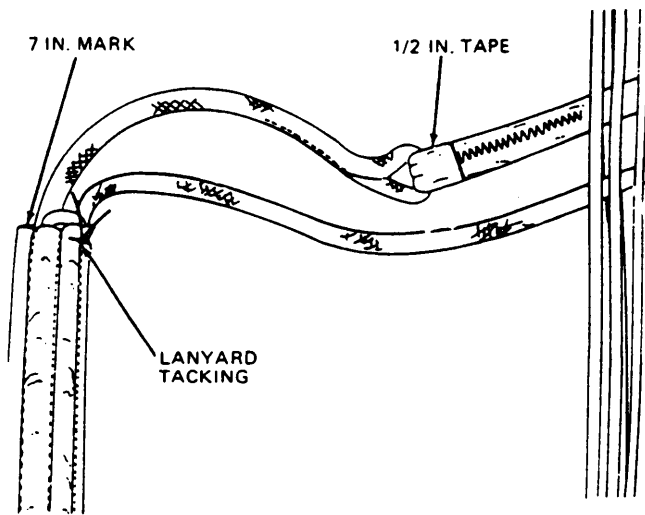

Figure 3-17.—Inspecting firing lanyard.

figure 3-16. Inspect the firing lanyard for proper stowage, as shown in figure 3-17.

In this inspection you may find that the firing lanyard has been pulled out of the stowage sleeve, or it may have been improperly stowed. To restow the firing lanyard, cut a piece of Type I nylon cord 30 inches long. This will aid you in stowing the lanyard.

Measure 7 inches from the sewn loop at the top of the firing lanyard and make a mark. This mark will leave you 7 inches of slack between the

sewn loop and the stowage sleeve. Form a bight the length of the stowage sleeve in the firing lanyard, and by using the Type I cord and a bodkin, pull the firing lanyard into the stowage sleeve, stopping at the bottom of the sleeve. (See figures 3-18 and 3-19).

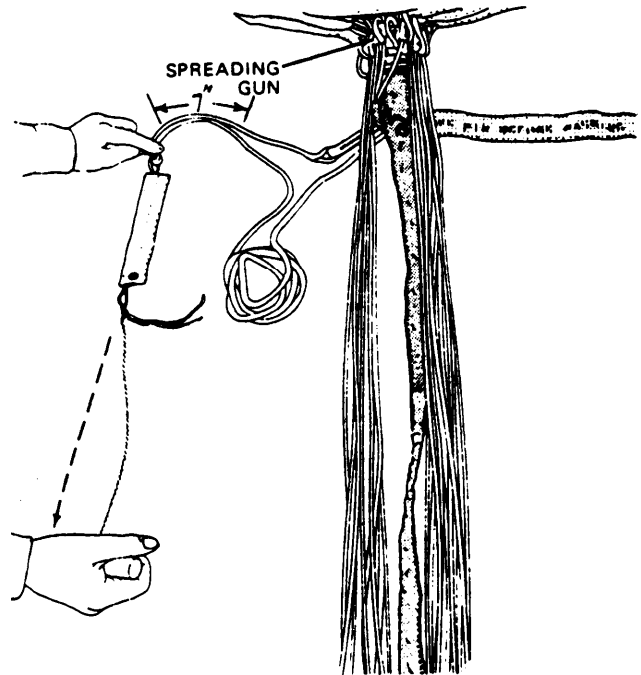

Figure 3-18.—Stowage sleeve and firing lanyard.

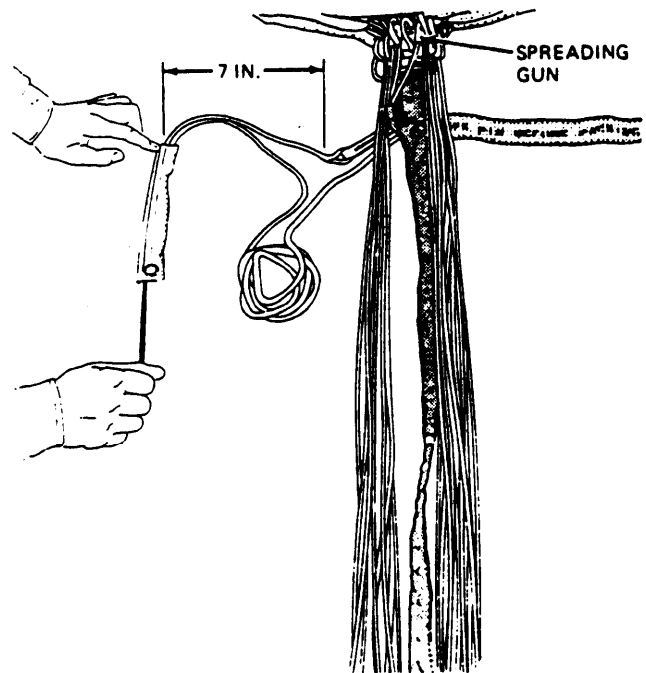

Figure 3-19.—Stowing firing lanyard.

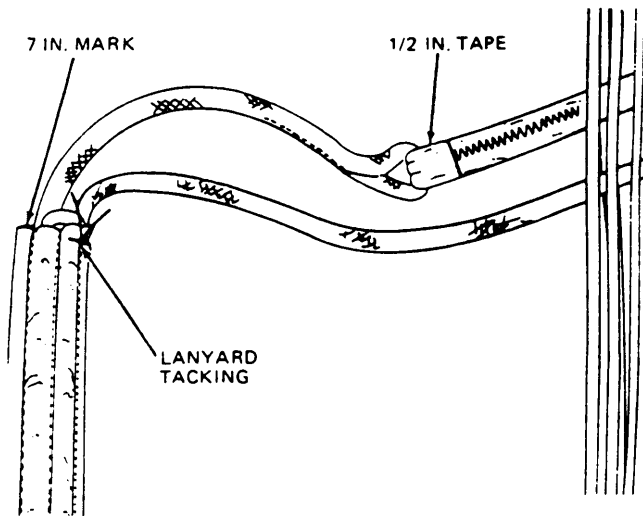

Figure 3-20.—Lanyard tacking.

Slowly remove the Type I line from the firing lanyard bight. Rapid removal of the Type I line from a firing lanyard bight could damage the lanyard. Form and stow an 8-inch bight of firing lanyard in the remaining stowage sleeve channel in the same manner. Tack the second lanyard bight to the stowage sleeve with one turn of waxed size A nylon thread, single. Tie the ends with a surgeon's knot followed by a square knot (fig. 3-20).

Insert the stowage sleeve into the extractor sleeve, open end first (fig. 3-21). Engage the fastener on the stowage sleeve to the fastener on the extractor sleeve. Engage the extractor sleeve fasteners on each side of the safety pin (fig. 3-22).

INSTALLATION OF AUTOMATIC PARACHUTE RIPCORD RELEASE ASSEMBLY

You have read about the automatic parachute ripcord release in chapter 2 of this manual. At this time, you will see how it is installed into a container. Before you actually attempt to install a release assembly, (fig. 3-23), you must first make sure that the inspection requirements in the NAVAIR 13-1-6.2 and the NAVAIR 13-600-4-6-3 have been complied with.

Now you are ready to proceed with the installation.

First, rotate the risers over the suspension lines and position the container on the packing table so that the bottom end is towards the canopy and

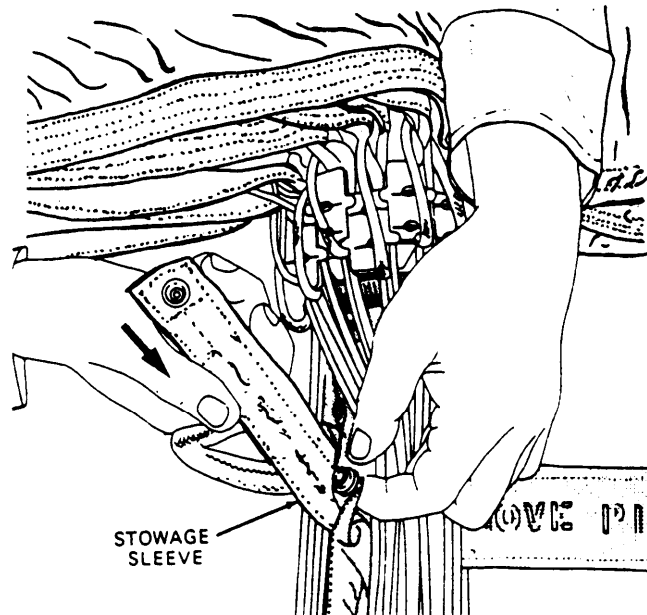

Figure 3-21.—Inserting stowage sleeve.

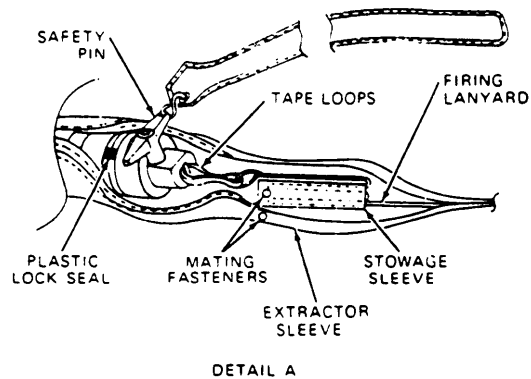
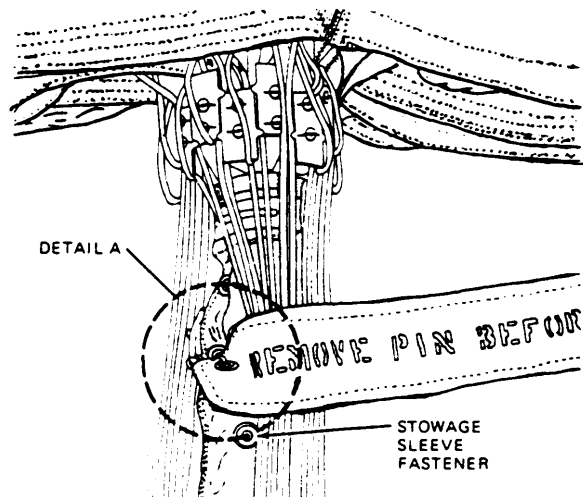

Figure 3-22.—Engaging snaps.

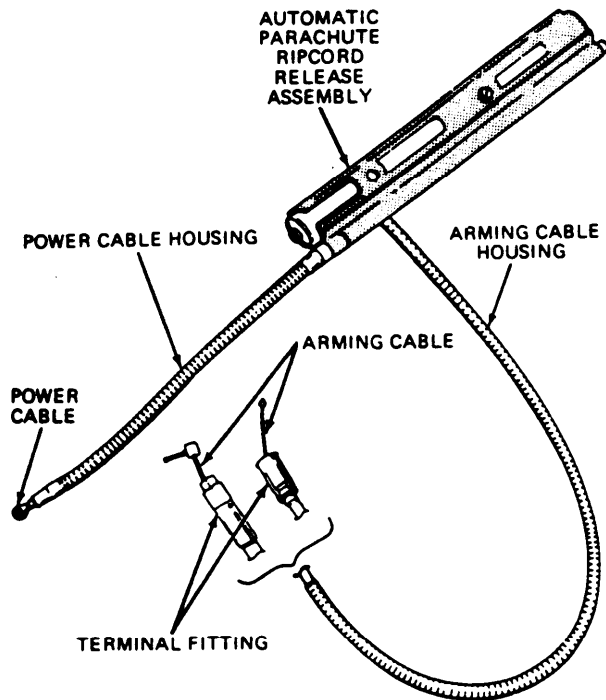

Figure 3-23.-Automatic parachute ripcord release assembly.

the inside faces up. Attach and crimp one end of both short container spring opening bands to the container eyes with hooks facing down (fig. 3-24).

You will find that different parachutes use different lengths of arming cables. There are also several different time-delay cartridges that can be used at this time. Before you attempt to install the arming cable or the cartridge, check the NAVAIR 13-1-6.2 to ensure you are using the right ones.

Inspect, arm, and assemble the automatic parachute ripcord release in accordance with the NAVAIR 13-1-6.2. Record the time delay, lot number, DODIC, part number, type of cartridge, and the expiration date on the Parachute Configuration, Inspection, and History Card.

Now you are ready to install the ripcord release into the ripcord release pocket, close the slide fastener, and secure the protector flap.

Insert the power cable through the buttonhole in the top end of the container. Route the end of the arming cable housing through the housing port located in the right side of the release pocket and through the buttonhole located on the right side of the container (fig. 3-25).

Close the fastener flaps of the release pocket.

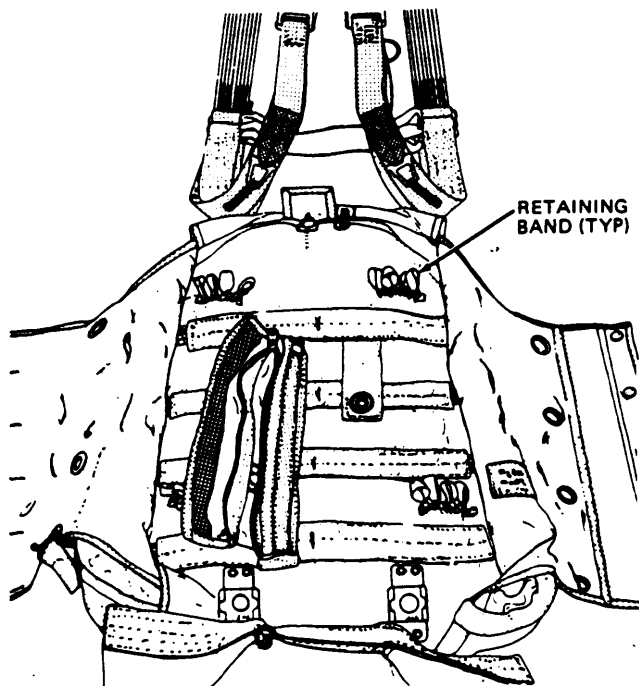

Figure 3-24.-Installing retaining bands.

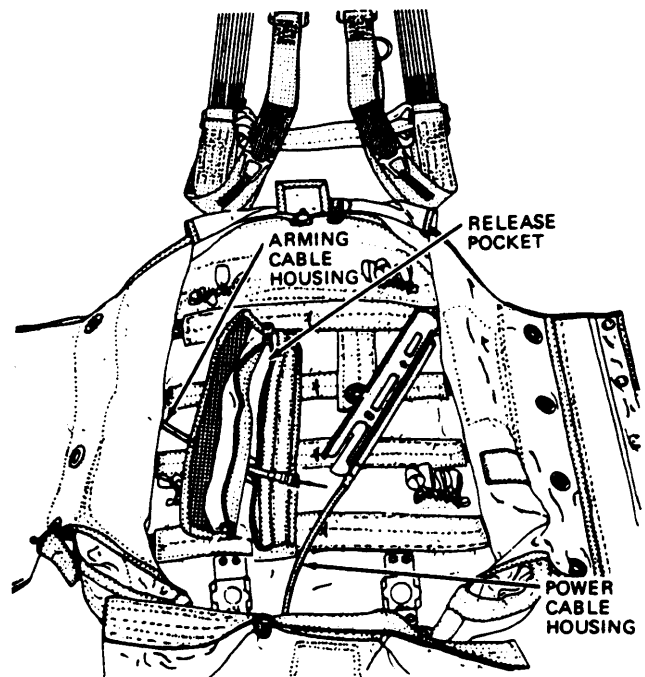

Figure 3-25.—Inserting power cable.

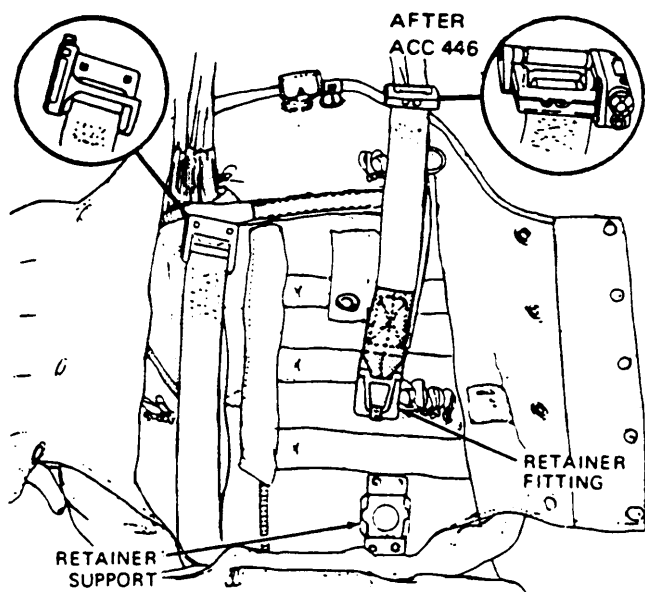

Figure 3-26.—Rotate risers.

ATTACHMENT OF CONTAINER ASSEMBLY TO RISER ASSEMBLY

To attach the container assembly to the riser assembly, you must remove the tension strap from the canopy peak, and remove the tension hooks from the connector links and the packing table. Rotate the risers onto the container, and secure the riser retainer fittings to the riser retainer supports (fig. 3-26). Now, position the lift web protector flaps over the riser and install the break cords. These two break cords, approximately 2 inches apart, are constructed with one turn of waxed size FF nylon thread, doubled. Pass the threads through the protector flap, under a support, up through the protector flap, and tie them snugly with a surgeon's knot followed by a square knot, as shown in figure 3-27. Repeat this procedure for the other riser.

INSTALLATION OF CONNECTOR LINK TIES

The connector link ties are a very important part of the rigging of the NES-12 and other parachutes that use the ballistic spreading gun. Not only do they prevent the risers from moving around inside of the container, they also prevent the premature deployment of the risers (riser blowout), which could cause line entanglement or premature firing of the spreader gun and provide an anchor point for the firing of the spreader gun.

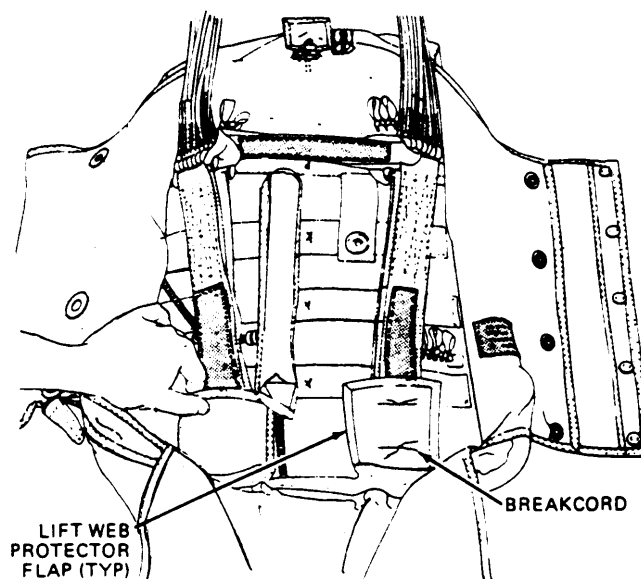

Figure 3-27.—Installing break cords.

To install connector link ties, proceed as follows

Cut two 12-inch lengths of 100-pound nylon cord and sear the ends. (Do not use waxed cord). Then, form a 1-inch loop in one end of each of the cords and secure with a bowline knot. Tie an overhand backup knot in the end of the cord (fig. 3-28).

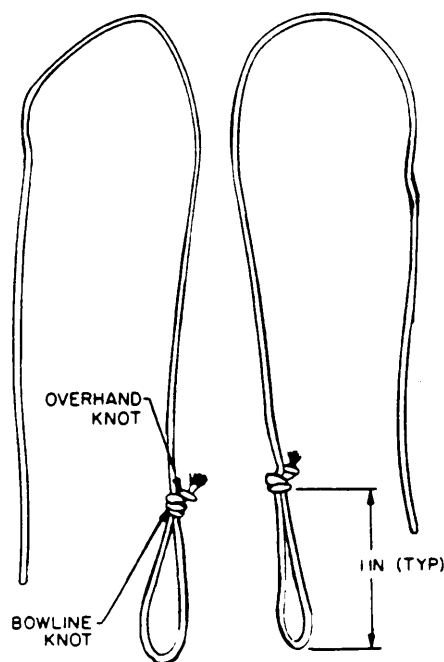

Figure 3-28.—Connector link ties.

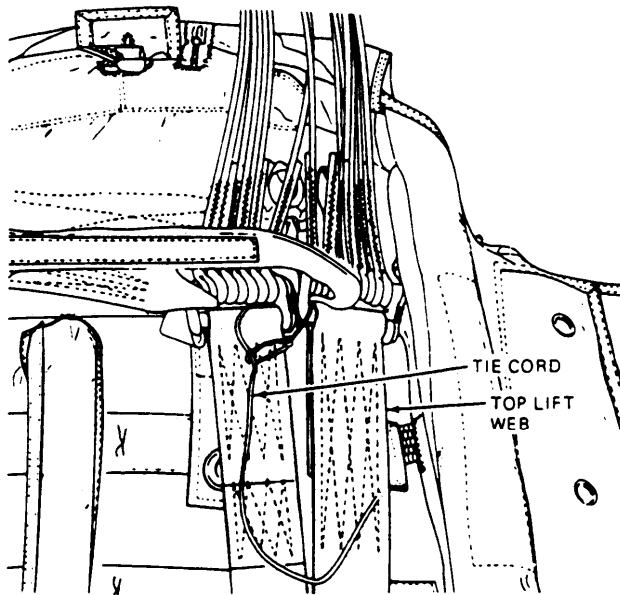

Figure 3-29.—Tying connector links.

Now position the connector links side by side so that the top connector links are to the right of the bottom connector links, then form a noose around the connector links located on the helper's side with one of the 100-pound tie cords, as illustrated in figure 3-29.

Tighten the noose and tie the free end of the tie cord to the bottom inboard cloth retaining band loop with three to four half-hitches. Trim excess cord.

Using the other tie cord in the same manner, secure the connector links on the packer's side.

INSTALLATION OF RELEASE ASSEMBLY LANYARD AND RIPCORD ASSEMBLY

Proceed in installing the lanyard release and ripcord assemblies by marking the clamp release lanyard 36 inches from the locking pin end. Next, fold the top end flap onto the container so that the baseplate faces up.

WARNING

ENSURE THAT THE BASEPLATE CLAMP IS POSITIONED OVER THE HEX NUT PRIOR TO INSTALLING THE LOCKING PIN (FIG. 3-30).

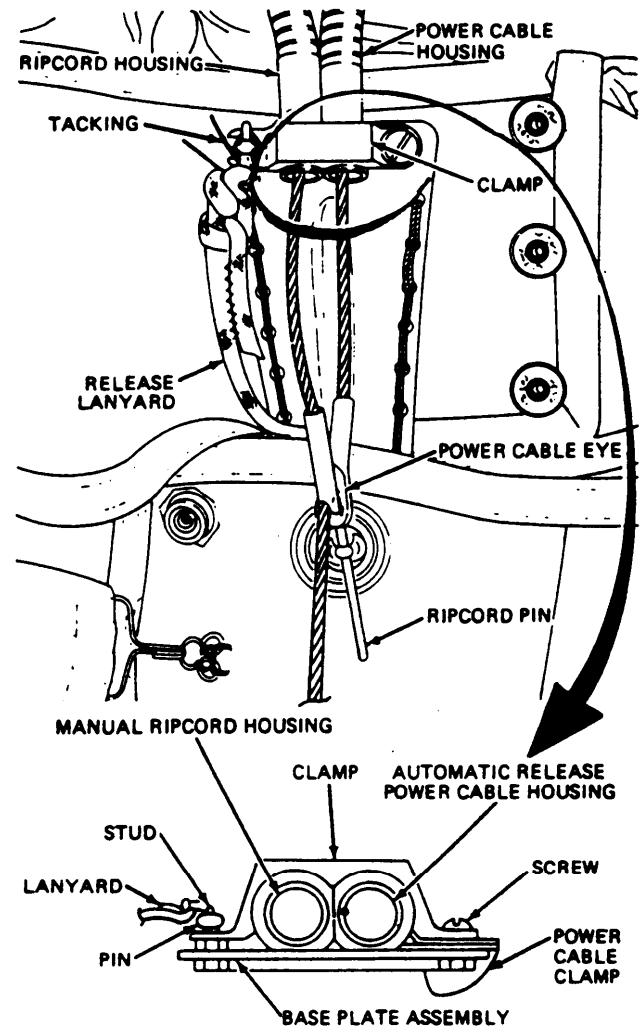

Figure 3-30.—Release lanyard assembly.

Now, position the clamp over the end fitting of the power cable housing. Insert the baseplate screw through the clamp holes and into the right-hand baseplate hole so that the clamp flange fits over the end of the baseplate, shown in figure 3-30.

Position the large slotted end of the baseplate clamp under the screwhead on the baseplate. Position the manual ripcord housing and power cable housing under the clamp with two flat sides together and the other two flat sides positioned against the baseplate. Place the clamp in the clamping grooves of the two housings. Position the small slotted end of the baseplate clamp over the baseplate stud. Insert the release lanyard locking pin into the stud hole. Secure the clamp in place. The locking pin should be finger tight; if necessary, slightly loosen the screw. Ensure the

two housings are correctly positioned and securely retained. Safety-tie the locking pin to the stud with one turn of waxed size FF nylon thread (V-T-295), single. Pass the thread through the lanyard knot and tie the ends with a surgeon's knot, followed by a square knot.

The next procedure is to insert the top ripcord pin through the beveled side of the eye in the power cable. Route the lanyard over the helper's side of the top end flap V. Tack the lanyard to the top end flap at the V with 1/8-inch slack between the locking pin and the tacking, passing the tacking around the lanyard. Use one turn of waxed size E nylon thread, single. Tie its ends with a surgeon's knot, followed by a square knot (fig. 3-31).

Route the lanyard along the inside of the top end flap to the helper's side of the automatic actuator power cable buttonhole. Tack the lanyard to the upper edge of the container with one turn of single, waxed, size E nylon thread (fig. 3-32), allowing 1/8 inch of slack between the tackings. The tacking must pass around the lanyard and not through it. Tie the ends with a surgeon's knot, followed by a square knot.

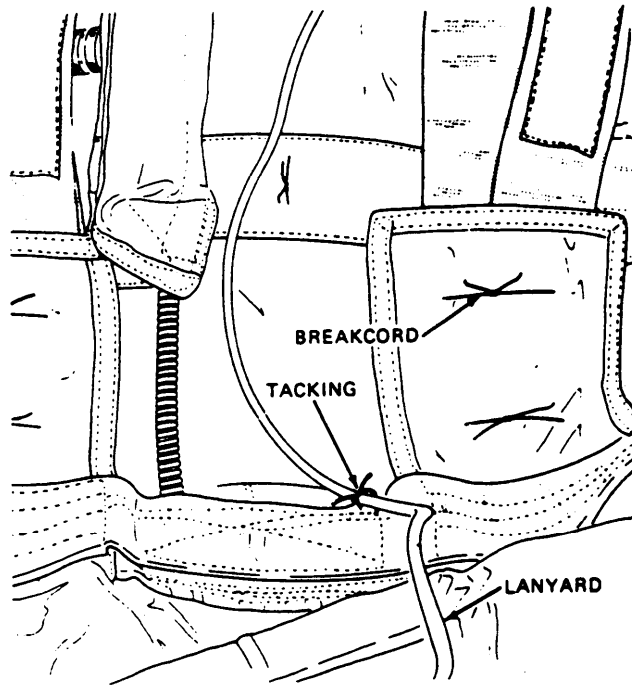

Figure 3-32.—Tacking release lanyard.

Reeve the lanyard through the lanyard guide grommet (fig. 3-33). Place the 3'6-inch mark on the lanyard over the bar on the inboard connector link located on the helper's side. Secure the lanyard to the connector link bar with a bowline knot. Ensure the lanyard is positioned between the webbing and the connector link end. Tie an overhand backup knot in the end of the lanyard.

You should have the QA inspect your work at this point.

ATTACHMENT OF FIRING LANYARD TO SUSPENSION LINE CONNECTOR LINK

Before attaching the firing lanyard, ensure that the safety pin is installed in the spreading gun. Then starting at the gun, route the firing lanyard between suspension lines 7 and 8. Slide the canopy towards the container and form an S-fold in the suspension lines large enough to allow the loop in the end of the firing lanyard to align with its connector links. Be careful to check to see that no suspension lines are dropped from the connector link bar.

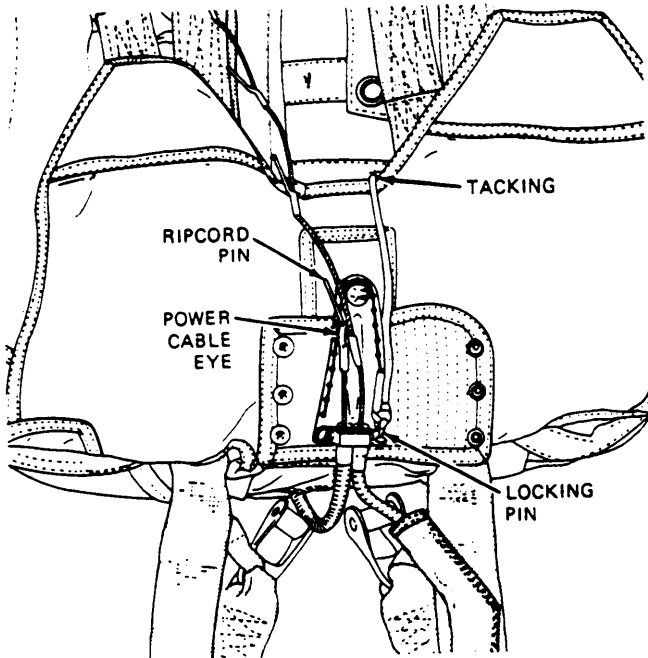

Figure 3-31.—Tacking locking pin.

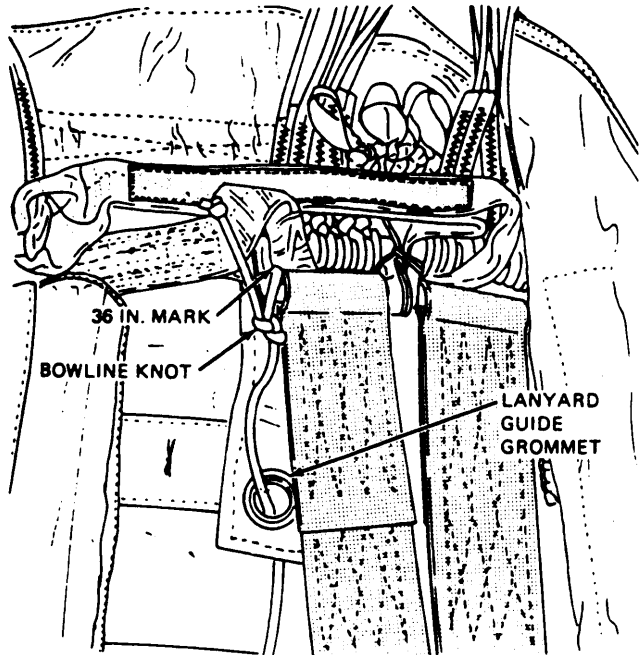

Figure 3-33.—Reeving release lanyard.

As you have read this chapter on the NES-12, you may have noticed that each time you have removed the yoke and plate assembly from the connector link, you have been told to tighten and torque the screw when reassembling the connector

link. This was done to prevent the torquing from being missed if you were only performing one of the many operations that require you to remove and replace the yoke and plate. If you have performed all the operations described, then, at this time, you do the final torquing before the suspension lines are placed into the container. Therefore, it is very important that you complete this process in the following manner and have it inspected.

Remove the yoke and plate assembly on the outboard top connector link located on the helper's side. Insert the connector link bar through the loop in the firing lanyard and reattach the yoke and plate assembly. Tighten the screw to a torque value of 20 to 25 pound-inches. Apply a tamper dot to the connector link screwhead using lacquer (TT-L-32, color 11136, insignia red or equivalent).

At this point, you have completed the rigging and you are ready for the packing procedure.

When actually performing any of these procedures, you should refer to the NAVAIR 13-1-6.2 and NAVAIR 13-600-4-6-3. Also, you will find that some of your rating exam questions will be taken from these NAVAIR manuals.

CHAPTER 4

AIRCREW PERSONAL PROTECTIVE EQUIPMENT

Learning Objective: Upon completion of this chapter, you will be able to recognize, inspect, and maintain aircrew personal protective equipment.

Aircrew flight clothing plays an essential role in the safety and survival of Navy aircrewmembers. It protects them from the elements and provides necessary comfort for efficient mission performance. Its primary function is to protect them against hazards such as fire, heat, cold, and immersion in water. Different combinations of protective clothing and equipment are used for various flight, emergency, and environmental conditions.

Naval aircrew protective equipment has also been designed to provide camouflage and other escape and evasion design features. Because of the wide range of environmental conditions in which aircraft must operate, a compromise between comfort and protection has, in some cases, been necessary. Postcrash fire and emergency cold water exposure are two critical areas where operational requirements are more important than flight comfort. Emphasis has been placed on developing materials and clothing assemblies that improve survival chances and, specifically, minimize injuries and prevent loss of life in case of an aircraft accident in either normal or hostile environments.

As an Aircrew Survival Equipmentman, some of your responsibilities are the care and maintenance of protective equipment. You may be required to order, inspect, modify, and repair this equipment.

MAINTENANCE SCHEDULING AND RECORDS

Planned maintenance of protective flight clothing is performed at the level of maintenance set forth in OPNAVINST 4790.2 (series). The levels of maintenance are either organizational, intermediate, or depot. Mission, time, equipment,

facilities, trained personnel and operational needs are the basic considerations in determining the level to be used.

Maintenance is divided into two categories—preventive and corrective. Preventive maintenance is the care and servicing needed to maintain equipment and facilities in satisfactory operating condition by providing for systematic inspection, detection, and correction of failures either before they occur or before they develop into major defects. Corrective maintenance is performed as a result of failure of the part/equipment, or to correct defects discovered during preventive maintenance.

Upon completion of any maintenance action (for example, inspections, repairs, modifications), you must make appropriate entries on the applicable maintenance documents. By properly maintaining these documents, you provide a complete maintenance history of the equipment throughout its service life.

The maintenance/material control officer, using the guidelines of OPNAV 4790.2 (series), schedules the preventive maintenance of all aircrew personal protection equipment for which he is responsible. Maintenance of this equipment must be thorough at all times. No careless treatment or willful neglect of aircrew personal protective equipment will go unnoted. The vital function of the equipment must be uppermost in the minds of all personnel concerned.

MAINTENANCE DOCUMENTS

Maintenance documents provide a systematic means of recording equipment history and documenting all maintenance actions performed on the equipment.

These documents consist of the following:

- Aircrew Personal Protective Equipment History Card, NAVAIR 10470/11, S/N: 0102-613-9110

- History Card—Aviation Crew Systems, OPNAV 4790/138

- Shop Process Cards

- Maintenance Data Collection System Forms, which include the following:

1. VIDS/MAF, OPNAV Form 4790/60
2. Support Action Form, OPNAV Form 4790/42
3. DOD Single Line Item Requisition System Document

- *Aircrew Personal Protective Equipment Manual*, NAVAIR 13-1-6.7

NOTE: All entries must be printed clearly with blue or black ball-point pen, or typewritten. Felt-tip pens or pencils are unacceptable for maintenance document or history card entry purposes. When you sign a maintenance document or history card, your full signature is required. Be sure to check the OPNAVINST 4790.2 (series) for the most up-to-date form numbers.

Aircrew Personal Protective Equipment History Card

This Aircrew Personal Protective Equipment History Card contains information pertaining to the personal protective equipment issued to one specific aircrew member. The card is divided into three sections: Section I records all aircrew personal equipment issued to the aircrew member. Section II is used for recording when calendar inspections are performed. It includes the inspector's full signature and collateral duty inspector (CDI) stamp. Section III records all modifications and repairs performed on the equipment. This card can be used as a custody card by units which operate a flight gear issue pool. When a new card is started for any reason, the old card is stapled on the back of the new card. When an aircrew member transfers to a new unit and keeps his personal protective equipment, the card is forwarded to his new unit.

History Card—Aviation Crew Systems

The Aviation Crew Systems History Card contains all information pertinent to a piece

of equipment. All maintenance tasks performed on the equipment (repairs, modifications, inspections) are recorded on the history card. In addition, the inspection cycle interval is entered in the upper right-hand corner of the card face. The record includes the Julian date and signature of the person accomplishing the maintenance task and the CDI's signature and number in the inspector's signature column. When, for any reason, a new card is initiated, the old card must be retained and stapled to the back of the new card. If the history card has been lost, initiate a new card using information from the manufacturer's nameplate. The history card must accompany the equipment to the intermediate- or depot-level maintenance activity. Whenever a piece of equipment is transferred from one unit to another, an updated history card is forwarded to the receiving unit. The card is placed in a suitable envelope and securely attached to the item. If the piece of equipment is an aircraft inventory item, the history card is inserted in the inventory logbook. If the receiving unit fails to receive the history card, a formal request for the card must be sent to the forwarding unit.

Shop Process Cards (SPC)

The Shop Process Cards (SPC) provide the maintenance man with a ready reference for performing scheduled maintenance on a specific type of aircrew personal protective equipment. Each SPC contains one or more detailed maintenance requirements. Illustrations, clearances, tolerances, charts, and part numbers are included when required. The minimum requirements for the performance of all or part of any particular periodic maintenance task (calendar or special inspection) are contained in a set of these cards. The work plan (or order of performing the maintenance work requirements) is prearranged, and is issued by the work center supervisor for the type of aircrew personal protective equipment being serviced.

Maintenance Data Collection System Forms

The following forms used in the Naval Aviation Maintenance Program are applicable to the aircrew personal protective maintenance: VIDS/MAF Form, Support Action Form, DOD Single Line Item Requisition System Documents, and Work Request Forms. Proper completion is essential to the function of the program. Instructions on their use can be found in the Naval Aviation Maintenance Program, OPNAVINST 4790.2 (series), and in the *Aviation Maintenance Ratings Manual 3 & 2*, NAVEDTRA 10342-1.

Aircrew Personal Protective Equipment Manual, NAVAIR 13-1-6.7

When you are working with personal protective equipment, your best friend is the *Aircrew Personal Protective Equipment Manual*, NAVAIR 13-1-6.7. This manual contains comprehensive and authoritative information on configuration, application, function, inspection, and maintenance of aircrew personal protective equipment.

MODIFICATIONS OF FLIGHT EQUIPMENT

Perform only authorized modifications. Unauthorized modification and deviations from the approved configuration of life support and survival equipment by individual crewmen could create unknown and possibly dangerous conditions.

NAVAIRSYSCOM is the only authority for modification to life support equipment and survival equipment. Such changes are usually accomplished by the cognizant field activity (CFA) via Aircrew System Changes or a change to the equipment procurement package. The NAVAIR 13-1-6.5 also permits an operating activity, with approval of the controlling custodian, to conditionally modify ONE unit of equipment in service to correct or overcome unsatisfactory conditions in that equipment item. Any other type of deviation, peculiar configuration, or modification to life support and survival equipment is not allowed at the operating level. The squadron riggers have no authority or responsibility to perform them.

If there is a conflict between CFA documents and NATOPS requirements, or if there is a need for clarification of equipment configuration or if equipment deficiencies are discovered, the CFA should be notified. The field activity having cognizance of most of the life support and survival equipment is the Naval Air Development Center (NAVAIRDEVCEN) at Warminster, Pennsylvania. For parachutes and related hardware, including torso harness, the CFA is the Naval Weapons Center (Code 6412), China Lake, California, 93555.

NADEP Pensacola has cognizance over all survival radios and URT-33 emergency beacons.

TYPES OF FLIGHT CLOTHING

The flight clothing covered in this chapter is designated to be worn by aircrew members as outer garments while on flight operations in

aircraft. As a squadron aircrew survival equipmentman, you may be asked to sew on squadron patches, name tags, and rate insignias. These items are authorized to be worn on flight clothing as directed by the local command. However, the total surface area of all patches (name tag excluded) may not exceed 50 square inches, and no one patch may be bigger than 4 inches in any given direction.

SUMMER FLYER'S COVERALL CWU-27/P AND BLUE FLYER'S COVERALL CWU-73/P

The CWU-27/P summer flyer's coverall and the CWU-73/P blue flyer's coverall (fig. 4-1) are

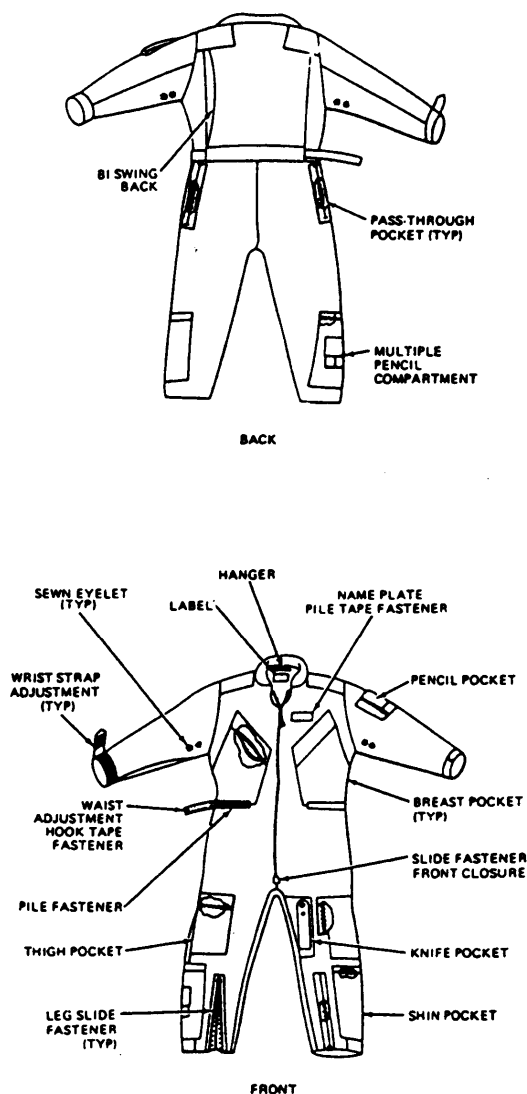

239.381
Figure 4-1.-Summer flyer's coverall, CWU-27/P and blue flyer's CWU-73/P.

designed to be worn as an outer garment in warm-temperature zones, and they provide protection in the event of an aircraft fire. They are designated for use by all aircrew members.

Configuration

The coveralls are one-piece, unlined garments that are made of Aramid cloth, which is a high-temperature resistant, inherently flame-retardant, synthetic fabric with no hot-melt point or drip characteristics. This lightweight fabric does not support combustion, but begins to char at 7000 to 800 °F. The fabric has abrasion resistance similar to nylon, and like nylon, Aramid is nonabsorbent. Because of this characteristic, cotton underwear should be worn under the coverall for optimum comfort. The color of the CWU-27/P is sage green, and the CWU-73/P is blue.

The CWU-27/P and CWU-73/P (fig. 4-1) have a slide fastener (zipper) front closure, side pass-throughs, biswing back, and hook and pile fastener size adjustments at the end of each leg. Also included are two breast patch pockets, one combination cigarette and multiple pencil compartment on the upper front left sleeve, and two thigh pockets. The CWU-73/P has epaulets to allow attachment of shoulder boards. Except for the knife pocket on the left thigh and the multiple pencil compartment pocket on the right lower leg, all pockets and pass-throughs have butted, beaded, covered, slide fasteners. If a hook blade knife (shroud cutter) is carried, it should be tied to the pocket cord and stowed in the knife pocket with the hook blade open for emergency use.

Fitting

The coveralls are fitted to the aircrew member, and their size normally corresponds to men's regular suit sizes. The coveralls are used with standard Navy personal equipment and may be worn over or under the anti-g garment. The coverall sleeves should always be worn down and closed at the wrist to ensure maximum fire protection.

Maintenance

The aircrew member's responsibility for maintenance of the coverall is limited to cleaning. The coveralls are inspected for general condition at intervals not to exceed 90 days. Repairs

performed at the organizational level are restricted to repairing open seams, small holes or tears, replacement of hook and pile fastener tape, and replacement of slide fasteners.

Only high-temperature resistant Aramid cloth (MIL-C-81280) and high-temperature resistant nylon thread (MIL-T-83193) should be used for repairs.

A new coverall should be laundered before use to soften the fabric and eliminate any possible skin irritation that might occur due to original fabric harshness. After tumble drying or during drip drying, the coverall should be hung on a wooden hanger. The fabric is a drip-dry type that requires no special handling, and it may be washed as frequently as needed. The coverall may be laundered by the aircrew member at home or in a commercial-type washer and dryer. Laundering in water up to 140°F and tumble drying up to 180°F does not damage or shrink the coveralls.

Use of a commercial fabric softener in the rinse cycle removes body oils during the laundering process. The fabric softeners also stop static cling. Ironing or pressing is permissible. However, it is difficult to remove wrinkles or creases due to the high-temperature resistant qualities of the material. Coveralls that are heavily soiled and/or stained with oil or grease may be cleaned with solvents normally used in commercial dry cleaning establishments. Dry cleaning or laundering does not compromise the flame-retardant properties, and no renewable flame-retardant treatment is required.

FIRE-RESISTANT FLYER'S GLOVES, GS/FRP-2

The fire-resistant flyer's glove (MIL-G-81188) is designated for use in warm-to-moderate temperature zones and provides protection in the event of aircraft fire. They are used by all aircrew members (fig. 4-2).

Configuration

The gloves are snug fitting and designed to provide maximum dexterity and sense of touch. If properly fitted they should not interfere with the operation of the aircraft and use of survival equipment. The gloves are available in sizes 5 to 11. Since the fabric is stretchable, the sizes will accommodate any size hand. The gloves are constructed of soft cabretta gray leather (palm and front portion of fingers), and a stretchable, sage green, lightweight knit Aramid fabric (entire back

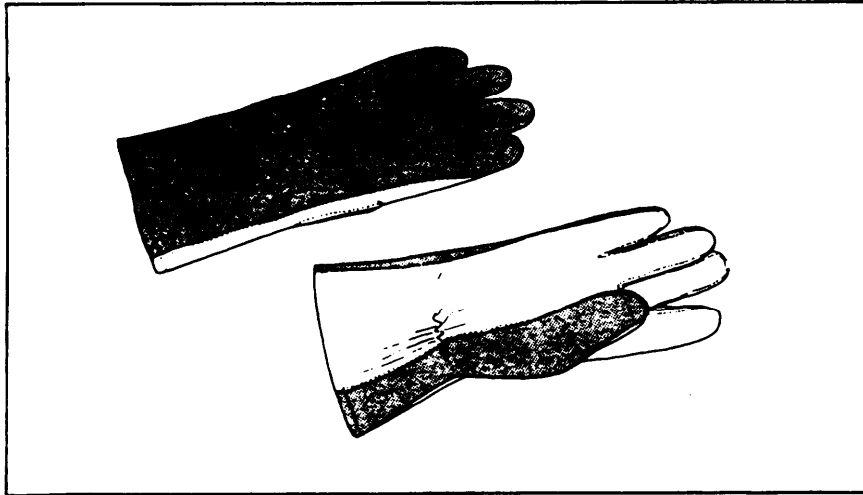

239.390

Figure 4-2.—Fire-resistant flyer's gloves, GS/FRP-2.

of hand). The cloth portion of the gloves will not melt or drip, and it does not support combustion. The fabric does begin to char at 700° to 800°F.

Fitting

The fire-resistant flyer's glove normally corresponds to the aircrew member's glove size. Determine the proper size glove on a trial fit basis. The glove must fit snugly.

Maintenance

It is the aircrew member's responsibility to clean the gloves. Repairs or other maintenance actions are performed at the organizational level or above, and are limited to restitching seams. The gloves are laundered as follows:

1. Put on the gloves and wash with a mild soap in water not over 120°F as if washing hands. When the gloves are clean, rinse and remove them from your hands. Squeeze, but do not wring the gloves to remove excess water. Never use a bleaching compound.
2. After removing excess water, place the gloves flat on a towel and roll the towel to cover the gloves. Ensure that the gloves do not contact each other and are not exposed to hot air or sunlight.
3. Letting the gloves come in contact with each other may harm the soft leather palms. The exposure to hot air or sunlight could cause the gloves to shrink.



Figure 4-2.—Flyer's boot.

FLYER'S BOOT

The impact-resistant flyer's boot (fig. 4-3) is designed to protect the aircrew member's foot against high-impact forces. The boot is water-resistant.

Configuration

The upper boot is black in color and is constructed of high quality calfskin. The inner liner is made with soft, full grain, glove leather. The boot is 8 inches high when fully laced, and is available in sizes 4 narrow through 14 1/2 extra wide. The traction tread outsoles and heels are

made of nonslip, nonmarking, jet-fuel-resistant rubber. The steel box toe is constructed of cold-rolled carbon steel to provide a safety margin through greater compression resistance. The boot is designed for use by all aircrew members.

Fitting

The boot is fitted to the aircrew member and normally corresponds to his regular shoe size.

Maintenance

The aircrew member is responsible for maintenance of the boot. Maintenance is limited to cleaning and polishing. Polish used for everyday care of shoes is acceptable. There are no authorized repairs, as the sole and heel should outwear the upper boot. Broken or worn laces may be replaced.

SV-2 SURVIVAL VEST

The SV-2B survival vest provides maximum useful storage for survival equipment, consistent with minimal bulk and weight. In addition, the survival vest provides for integration of a life preserver, anti-g coveralls, and the chest-mounted oxygen regulator. It does not interfere with use of either the regular or integrated-type parachute harness. The SV-2B vest is the latest authorized configuration for this series of survival vest.

Configuration

The SV-2B survival vest is constructed basically of nylon cloth. An adjustable harness, leg straps, and an entrance slide fastener provide a means of fitting and securing the vest to the aircrew member. Elastic straps on the rear allow greater comfort and mobility of the wearer. Pockets are provided for stowage of survival items (fig. 4-4). When required, the chest-mounted oxygen regulator is located inside a pocket secured to the vest by means of hook and pile tape.

Fittings

The basic SV-2B survival vest is designed to fit chest sizes from 40 to 48 inches. By changing the elastic straps on the rear, the vest may be adapted to a wider size range. To fit an SV-2B properly, have the aircrew member wear all his normal flight gear, including the MA-2 torso harness, if used. Put the SV-2B vest on as if it

were a jacket. Pass the leg straps through the crotch and attach the snap hooks. Adjust the leg and shoulder straps so that they are snug and the bottom of the vest is just above the hips. Examine the SV-2B for proper fit. If it is too loose, the elastic straps must be shortened. If it is too tight, you must lengthen the elastic straps. The procedures for this adjustment, as well as maintenance, calendar inspections, and cleaning, are covered in-depth in the *Aircrew Personal Protective Equipment Manual*, NAVAIR 13-1-6.7.

ANTIEXPOSURE ASSEMBLIES

Antiexposure assemblies are composed of several garments that protect the aircrew member in the event of immersion. Constant wear assemblies provide additional protection from cold weather. The constant wear assemblies consist of a waterproof outer garment worn over a ventilation liner and/or cold weather underwear.

The quick-donning antiexposure suit is carried in the aircraft, and donned only in case of emergency. It consists of a waterproof outer garment equipped with permanently attached boots and wrist and neck seals. An inflatable hood and antiexposure mittens are stowed in the pockets. In case of emergency, the assembly is donned over the regular flight clothing.

Either continuous-wear or quick-donning antiexposure suits, as appropriate, are provided for flight personnel and passengers when there is a significant risk of crashing in the water, and when any of the following conditions prevail:

1. The water temperature is 50°F or below.
2. The outside air temperature (OAT) is 32°F (wind chill factor corrected) or below.

If the water temperature is between 50° and 60°F, the commanding officer of the unit concerned considers the following search and rescue (SAR) factors:

1. The maximum probable rescue time. This should be a function of mission distance, SAR equipment, and SAR location.
2. The lowest temperatures that will occur in the mission area during the time period of the flight.
3. Then by using table 4-1, he determines whether antiexposure suits are required.

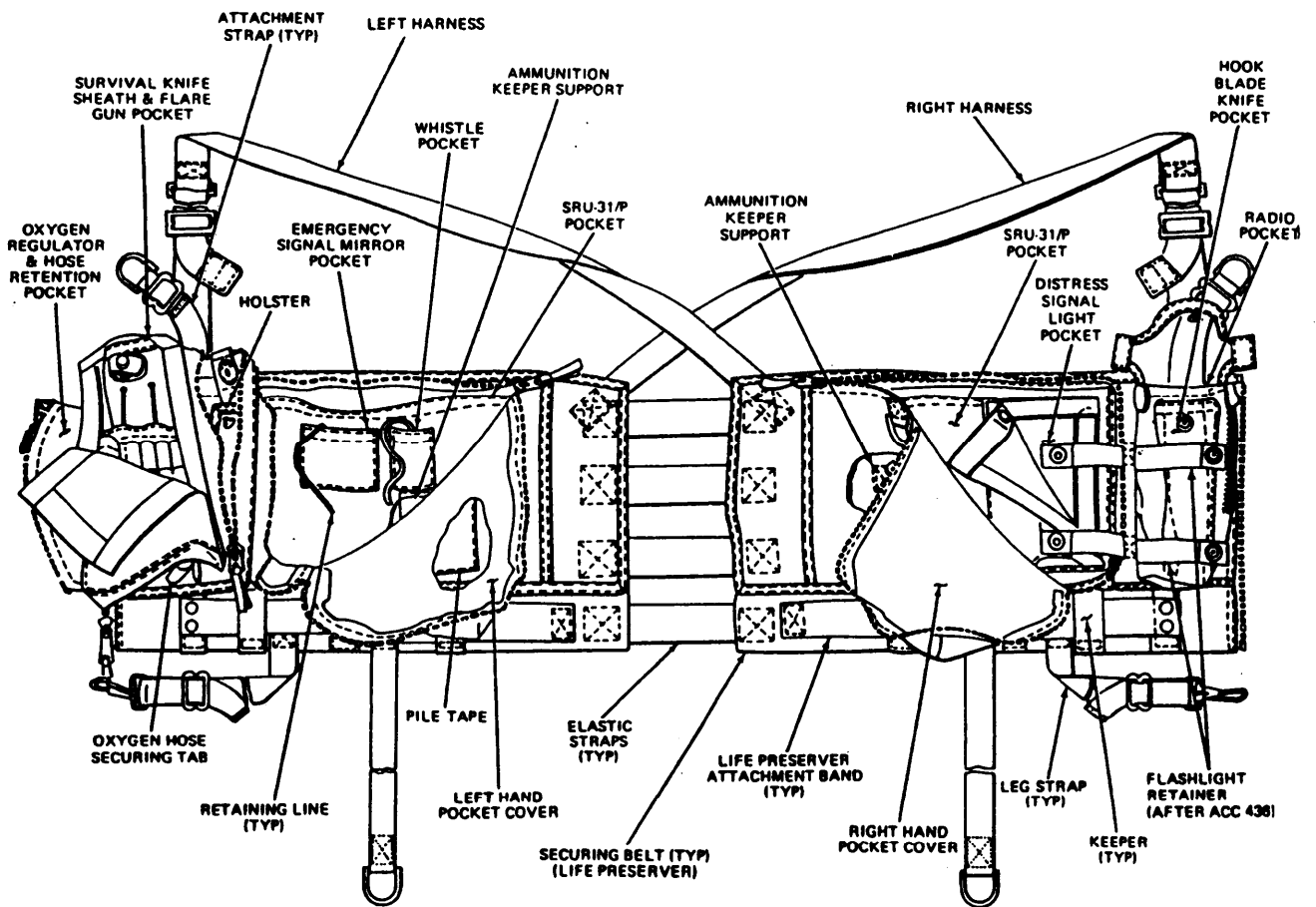
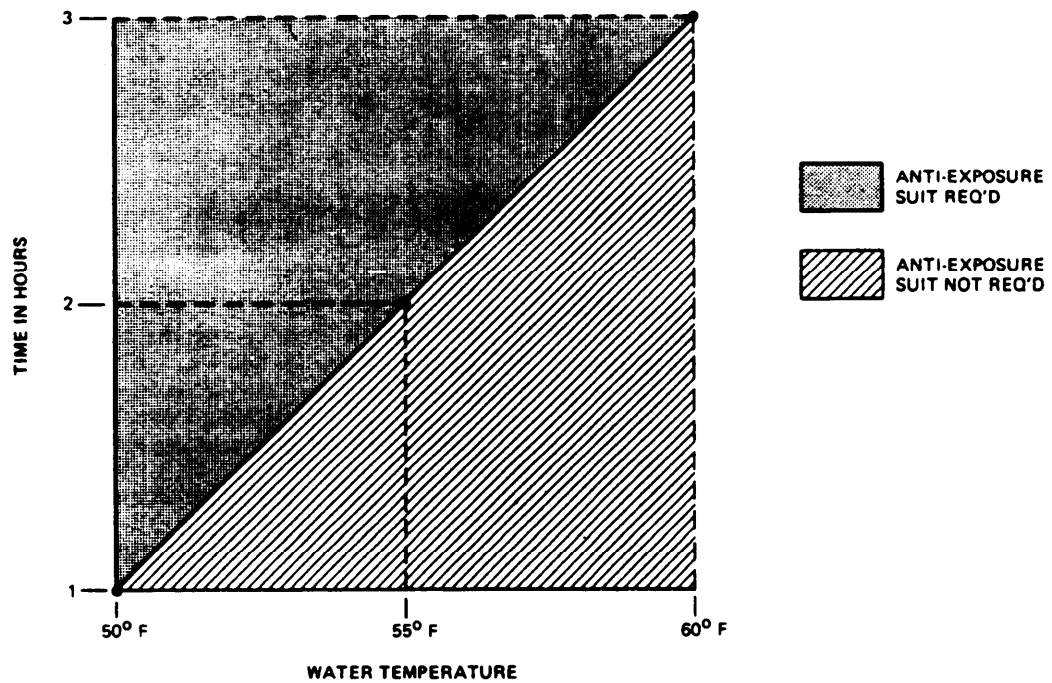

Figure 4-4.—SV-2B survival vest.

239.424

Table 4-1.—Antiexposure Suit Requirements



4. When water temperature is below 60°F and antiexposure suits are not required, the flight equipment includes antiexposure, high-temperature resistant undergarments. Wearing double layers of these undergarments can significantly improve antiexposure protection.

A/P22P-6(V)2 and A/P22P-6A(V)2 Antiexposure Assemblies

The A/P22P-6(V)2 and the A/P22P-6A(V)2 antiexposure assemblies (fig. 4-5) are continuous

wear assemblies designed to keep the wearer dry. The complete assemblies provide protection from the thermal effects of cold water immersion in the event of emergency overwater bailout. The assemblies differ only in the type of liner that is worn. The A/P22P-6(V)2 assembly uses the CWU-23/P liner, and the A/P22P-6A(V)2 assembly uses the CWU-72P liner. Table 4-2 lists the components that make up the A/P22P-6(V)2 and the A/P22P-6A(V)2 antiexposure assemblies.

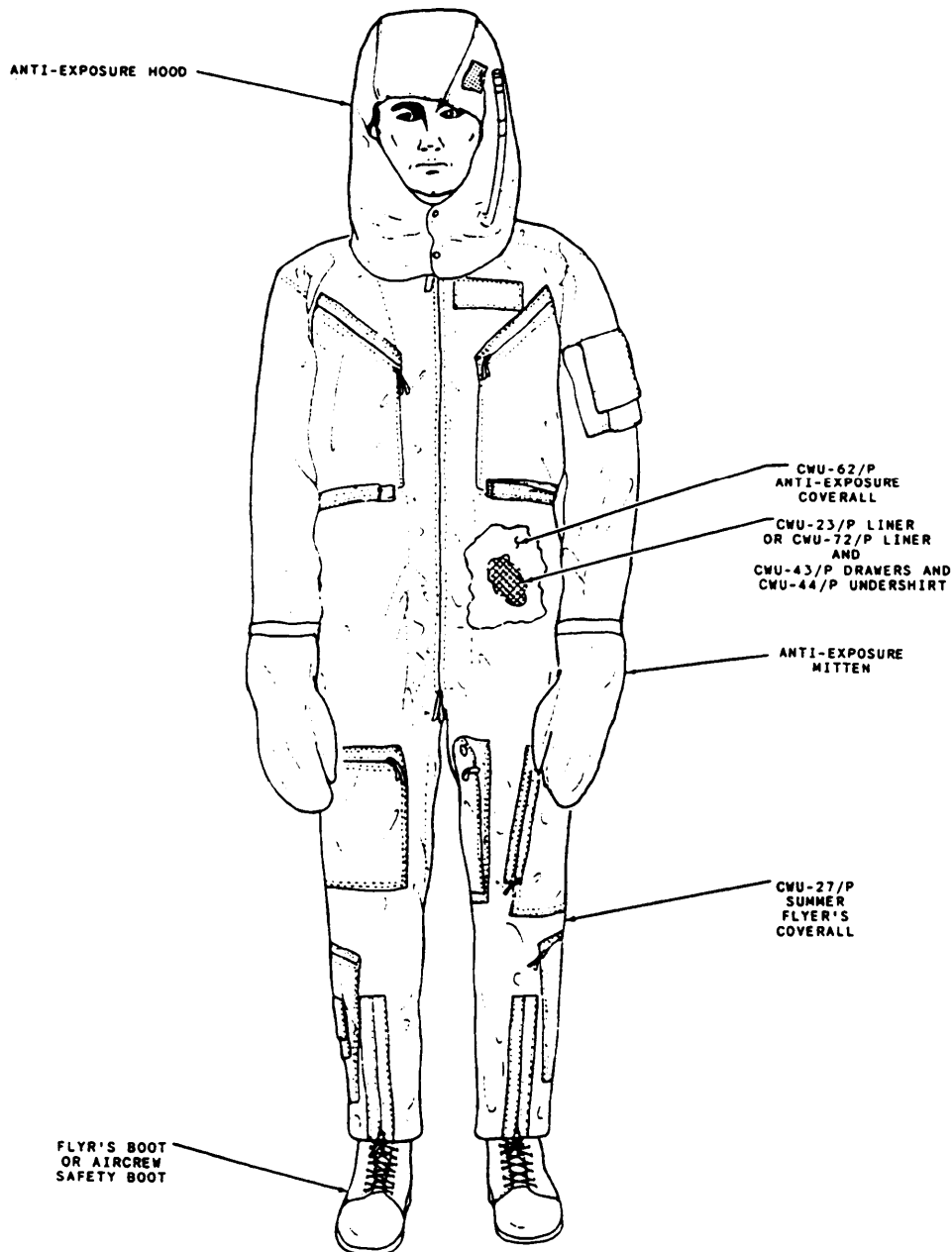

Figure 4-5.—A/P22P-6(V)2 and A/P22P-6A(V)2 antiexposure apparel assemblies, constant wear.

Table 4-2.—A/P22P-6(V)2 and A/P22P-6A(V)2 Anti-exposure Apparel Assemblies

COMPONENT NOMENCLATURE
CWU-43/P Drawers
CWU-44/P Undershirt
CWU-23/P Liner, Anti-Exposure (A/P22P-6(V)2 Only)
CWU-72/P Liner, Anti-Exposure (A/P22P-6A(V)2 Only)
CWU-62/P Anti Exposure Coverall
SRU-25/P Rubber Socks
CWU-27/P Summer Flyer's Coverall
Hood, Anti-Exposure
Mittens, Anti-Exposure

The A/P22P-6(V)2 or the A/P22P-6A(V)2 antiexposure assembly should be worn by aircrew members for flight operations in accordance with the climatic and operational requirements established by the *NATOPS General Flight and Operational Instructions Manual*, OPNAVINST 3710.7 series.

The A/P22P-6(V)2 and the A/P22P-6A(V)2 antiexposure assemblies are intended to provide the aircrew member with a lightweight coverall assembly that allows for the performance of all required flight operations without restricting any body movements. The coveralls are moisture/vapor permeable to prevent excessive buildup of body heat. In the event of immersion in water, the suit fabrics will not allow water to enter, keeping the wearer dry. All components of the assembly must be worn to achieve the greatest level of exposure protection.

The A/P22P-6(V)2 and the A/P22P-6A(V)2 antiexposure assemblies should be properly sized to the aircrew member based on his height, weight, and chest measurements. You would determine the chest circumference by taking a tape measurement at nipple height with the aircrew member wearing one cold weather undershirt. Refer to the *Aircrew Personal Protective Equipment Manual*, NAVAIR 13-1-6.7, for proper sizes.

CWU-23/P LINER. The CWU-23/P liner (fig. 4-6) is a one-piece garment that is supplied in 12 sizes. The liner is worn directly under the CWU-62/P antiexposure coverall, and over the recommended underclothing. The liner provides

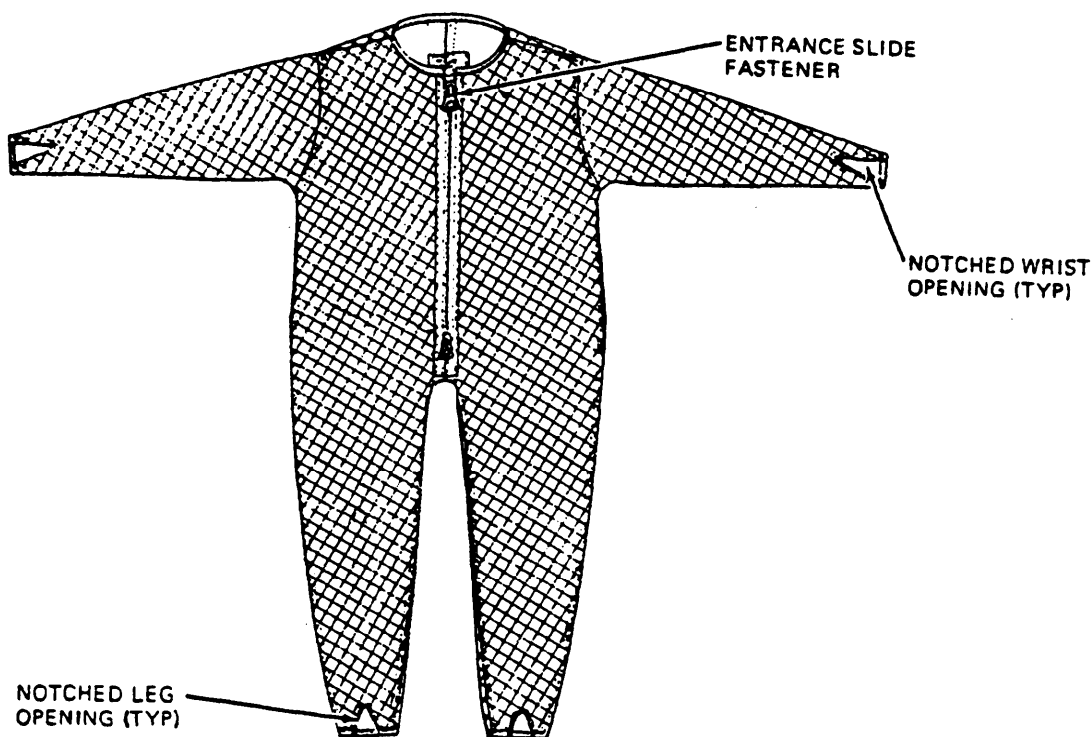

Figure 4-6.—CWU-23/P liner.

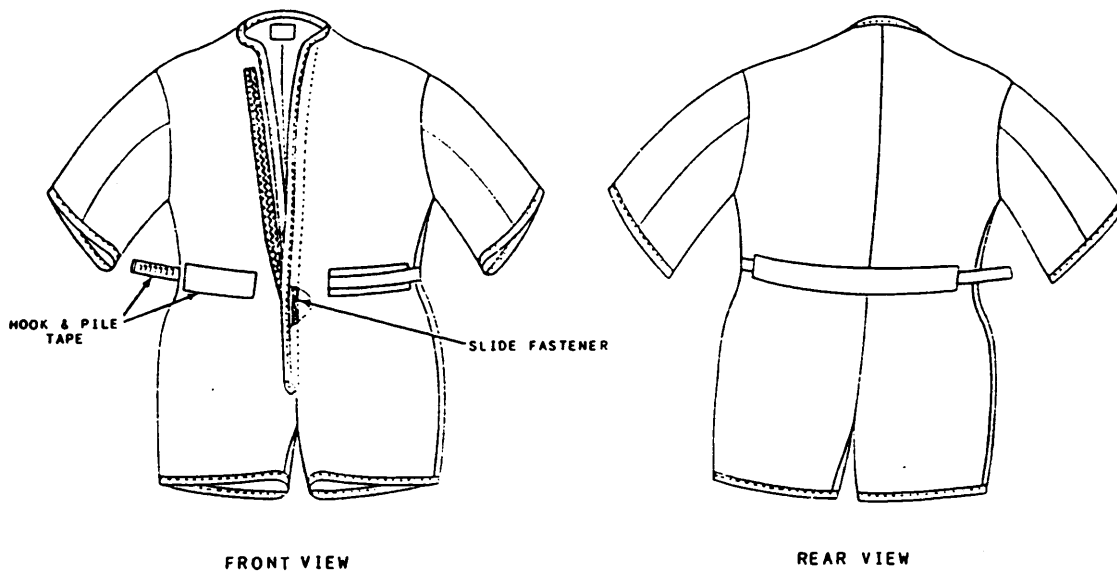

Figure 4-7.—CWU-72/P liner.

an inner layer of 100% cotton and an outer layer of polypropylene netting.

Each sleeve ending has a coated stretch fabric insert to permit easy insertion of the hands and to reduce bulk. The leg endings are short enough to clear the tops of the flight boots, thereby eliminating bulk. They are notched at the front to allow standard wool or cotton socks to be pulled up over the liner legs, and to hold the liner legs in place when the CWU-62/P coverall is donned.

CWU-72/P LINER. The CWU-72/P liner (fig. 4-7) is a one-piece garment and is supplied in nine sizes. The liner is worn directly under the CWU-62/P coverall and over the recommended underclothing. The liner provides a layer of thermal protection, and is made of 100% olefin microfiber thermal insulation sandwiched between two layers of high-temperature resistant Aramid fabric.

CWU-62/P ANTIEXPOSURE COVERALL.— The CWU-62/P antiexposure coverall (fig. 4-8) is a one-piece garment and is supplied in 12 sizes. The coverall should not be worn in direct contact with the skin. It is a lightweight coverall that prevents water from entering, but permits bodily produced moisture vapor to pass out, thus minimizing heat and moisture buildup. Proper maintenance is essential to the life and safety of this coverall, as well as proper sizing and fitting. The neck seal and wrist seals are

manufactured from natural rubber and are flocked on both sides. The entrance opening and the relief portal are sealed with a water and pressure-sealing slide fastener.

To fit the CWU-62/P coverall, the neck and wrist seals may be trimmed at the initial fitting, but the seals tend to adjust to the aircrew member after a short period of time. If no excessive seal restriction exists, and the seal fit is acceptable to the aircrew member, the seals should be left as they are. Neck seals need to fit snugly and remain in direct contact with the neck through all normal head movements. Wrist seals must fit tightly enough to prevent water entry, but not tight enough to restrict blood flow. If seal sizing is required, proceed as follows:

CAUTION

DO NOT USE A BALL-POINT PEN OR LEAD PENCIL TO MARK THE COVERALL MATERIAL. USE ONLY TAILOR'S CHALK OR A CHINA MARKING PENCIL.

1. If neck seal trimming is necessary, mark a line around the circumference of the neck opening. Trimming increments should not be more than one-eighth inch at a time.

2. Carefully cut along this line with a sharp pair of scissors.

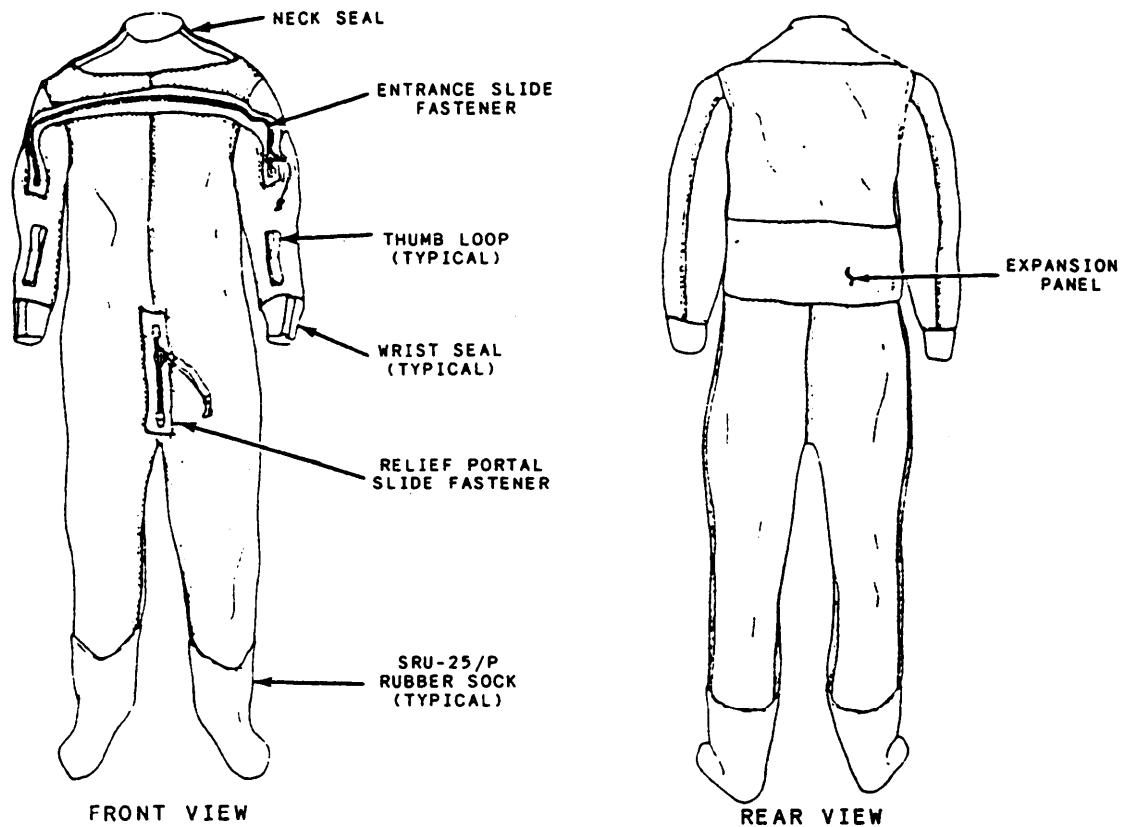

Figure 4-8.—CWU-62/P antiexposure coverall.

3. Trim the wrist seals in the same way as the neck seal, except the trimming increments must not exceed one-third inch at a time.

4. After trimming the seals, have the aircrew member put on the coveralls to determine the seal restriction and the water-sealing characteristics. If any adjustments are necessary, you must repeat steps 1 through 3.

SRU-2WP RUBBER SOCKS.— The SRU-25/P rubber socks are supplied in eight sizes. The rubber socks are one-piece and are molded to shape to provide comfort and a good fit. The tops of the socks extend above the flight boots to reduce bulk and restriction.

The size of the SRU-25/P rubber socks will be governed by the size of the flight boot to be used. Usually, a rubber sock one size smaller than the boot to be used will provide an acceptable fit. The aircrew member should wear a pair of heavy wool socks, then put on a pair of SRU-25/P rubber socks corresponding to his normal boot size. The rubber socks should be worn in a slightly stretched condition to prevent wrinkles or bulk

in the boot, but they must not be too tight. Larger or smaller rubber socks and/or boots may be required for a proper fit.

To fit the rubber socks, select the correct size of rubber socks and fit them to the CWU-62/P coveralls as follows:

1. Have the aircrew member put on the antiexposure assembly (except the hood, mittens, and flight suit), the MA-2 torso harness, if applicable, and a pair of properly fitted, heavy wool socks.

2. Mark the coverall legs and socks (L and R) on the inside and front and back. This is to ensure the socks are matched to the correct leg during installation.

3. Have the aircrew member sit in a straight-back chair with his legs drawn back, heels directly below the kneecaps, and his feet flat on the floor.

4. Turn the top 2 inches of sock down, forming a temporary cuff. Mark the circumference of the coverall legs where they meet the

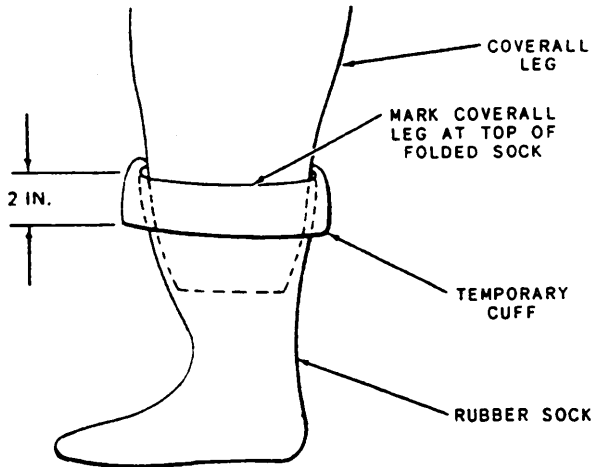

Figure 4-9.—Fitting the SRU-25/P rubber socks.

top of the folded socks (fig. 4-9). Have the aircrew member take off the coveralls. Remove the top 2 inches of the socks with a pair of sharp scissors.

5. Remove excess material from the coverall leg by cutting a line 1 inch below the mark that was applied in step 4. Ensure the leg is cut perpendicular to the lengthwise direction of the leg. Make your alignment marks at the front of the coverall legs and socks to ensure the socks will be properly aligned with the legs during the attachment process.

6. Turn the coveralls inside out and lay them flat, facing up.

NOTE: When you attach the socks to the coveralls, the right sock is on the right leg and the left sock is on the left leg.

7. Insert the sock into the leg opening, so that the right sides of the sock and coverall leg are facing each other, and the toe is pointing up (toward the front) (fig. 4-10).

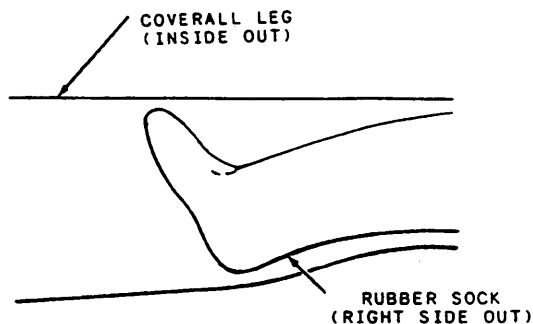

Figure 4-10.—Attaching the rubber sock to the coverall leg.

8. Beginning at the front of the leg, make sure the alignment marks are matched. Then attach the sock with one row of stitches, one-fourth inch from the cut edges, five to seven stitches per inch, using nylon size E thread. Overlap the stitching one-half inch. Do not backstitch.

9. Fold the cut edges of the seam over the sock. Make the fold as near the stitch line as possible. Apply one layer of 1 1/2-inch seam tape over the seam, keeping the stitch line and the cut edges as nearly centered under the tape as possible. Overlap the ends of the seam tape 1 inch.

10. Additional information on maintenance procedures, inspection cycles, and test equipment for antiexposure assemblies is covered in the *Aircrew Personal Protective Equipment Manual*, NAVAIR 13-1-6.7.

ANTI-G GARMENTS

Although there is no limit to the speed a human can endure in straight and level flight in an aircraft, changing speed or direction can produce inertia to which the body has a sharply limited tolerance. In the case of extreme stresses exerted by forces of the type met in seat ejection, ditching, or parachute opening shock, the short duration of the force restricts its effects. However, changing the direction of flight often produces stress forces equal to several times the normal value of gravity for periods longer than a second. These forces can have dangerous effects.

At 5 g's (five times the force of gravity), the pilot's body is exposed to a force that increases its weight and that of its components five times. This increased weight has many effects. The pilot is pushed down into his seat. His arms and legs feel like lead, and manipulation of the controls becomes more difficult. In addition, the extra weight of the internal organs causes abdominal and chest discomfort. Most important, however, is the effect on the circulatory system.

At 5 g's the pressure exerted by the column of blood between the head and the heart becomes just about equal to the blood pressure in the arteries. As a result, the pressure supplied by the heart is not great enough to pump an adequate supply of blood to the head.

To counteract these effects, the pressure in the arteries must be increased above the heart level. At the same time, distended vessels and tissue and fluid spaces in the regions below the heart must

be restored to normal. This is accomplished by the anti-g garment.

With the anti-g system, compressed air is metered to the garment in proportion to the gravitational force being exerted. The bladders of the garment inflate, compressing the legs and abdomen of the wearer by an amount also proportional to the gravitational force. Thus, the garment prevents blood collecting in the abdomen and lower extremities and forces blood from the lower to the upper part of the body. This effect increases blood flow to the heart and increases resistance to the shifting of blood to the lower limbs. In addition, it raises the diaphragm, decreasing the distance between the heart, the eyes, and the brain. Altogether, it increases the tolerance of the pilot an average of about 2 g's.

Without an anti-g garment, the average pilot can withstand 4.5 to 5.5 g's without losing vision or blacking out. With a garment, he is capable of withstanding 6.0 to 7.0 g's. However, this protection is available only for sustained accelerations of 4 to 5 seconds or longer in maneuvers other than snap maneuvers.

Anti-g equipment does not offer protection in snap maneuvers where 10 to 12 g's can be applied in approximately 1 second. Such brief forces are not as harmful to the body as lesser forces sustained for a number of seconds.

CSU-15/P ANTI-G GARMENT

The CSU-15/P anti-g garment (fig. 4-11) consists of a fire-resistant Aramid cloth outer shell, which houses a bladder. It is cut away at the buttocks, groin, and knees. The outer shell has waist and leg entrance slide fasteners, six adjustment lacing areas with lacing covers, and two easily detached leg pockets with slide fastener closures. The bladder system is constructed of polyurethane-coated nylon cloth and covers the abdomen, thighs, and calves. The bladder system is fitted with a hose for connecting directly to the aircraft anti-g system. This anti-g garment is available in six sizes.

CSU-15/P anti-g garments are issued to individual aircrew members, and are used in conjunction with standard Navy personal equipment.

Fitting the CSU-15/P Anti-g Garment

The CSU-15/P anti-g garment is fitted and adjusted to the aircrew member on a best-fit basis.

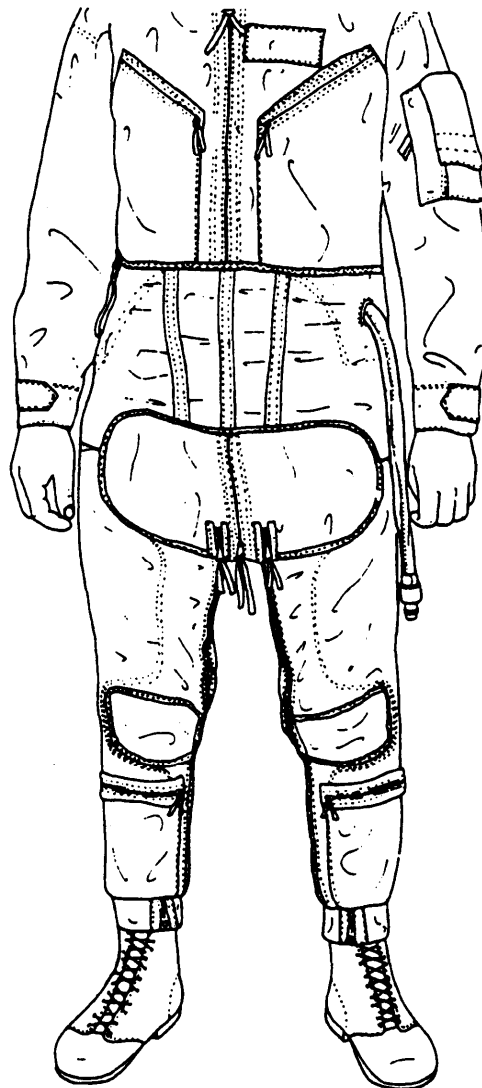

239.395

Figure 4-11.—CSU-15/P anti-g garment.

The cords are laced in the same direction as the applicable lacing slide fastener closure. With a proper fit, the lace adjustment should be tightened approximately halfway, and the cutout should expose the knees, groin, and buttocks without binding or hindering movement. The garment should fit snugly, but not tight, with the bladder deflated. The inflated bladder should compress the waist, thighs, and calves firmly and evenly.

With bladder deflated, lace adjustments are tightened to provide a snug (not tight) comfortable fit, especially at the waist.

Installing The CSU-15/P Anti-g Garment Hose

This anti-g hose also must be cut to size, and an end fitting installed after correct garment size has been determined. To fit the anti-g hose, proceed as follows:

Have the aircrew member don the anti-g garment and sit in the aircraft. Attach the quick disconnect on the hose to the aircraft supply system. If the hose is too long, measure it and mark where to cut it.

Lay the hose out flat. In a single operation, cut the outer covering, inner hose, and spacer/reinforcement at the mark. Sear completely around the end of the outer cover to prevent fraying.

Remove the tape, clamp, and severed portion of hose from the quick-disconnect connector.

Position the spacer/reinforcement on the rubber extension of the connector (fig. 4-12). Butt the end against the raised portion of the connector, and cover it with three turns of electrical tape.

Slide the inner hose (bladder material) over the connector and butt it against the raised portion of the connector. Ensure the spacer/reinforcement is not twisted. Secure it with three turns of tape.

NOTE: In some instances it may be necessary to build up the outside diameter of the hose area under the clamp with three to six turns of tape to get the clamp tight.

Slide the outer cover of the hose over the inner hose until it butts against the raised portion of the connector. Install a clamp as shown in figure 4-12. Cover the clamp with three turns of tape or a heat-shrinkable insulation sleeve.

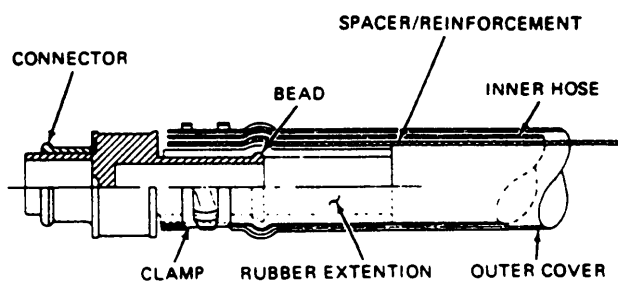

239.396

Figure 4-12.-Assembly of hose and quick-disconnect fitting.

Finally, ensure that the fitting is properly inserted in the hose, and clamp it properly positioned between the raised bead and the body. Ensure that the clamp is tightened sufficiently by grasping the hose and fitting and jerking sharply.

Inspections

A preflight inspection is performed by the aircrew member before each flight. The interval between preflight inspections must not exceed 14 days. To perform the preflight inspection, do the following:

- Check the slide fasteners for secure attachment, ease of operation, and corrosion.
- Visually inspect all seams for loose or broken stitching.
- Visually inspect outer shell and hose covering for holes, tears, and abrasion.
- Check the quick-disconnect connector for nicks, corrosion, and proper operation.
- Inspect the laces and lacer loops for secure attachment and excessive wear.

If you find any discrepancies, forward the garment to the aviator's equipment branch for a periodic inspection.

The calendar inspection is made by an Aircrew Survival Equipmentman prior to placing the anti-g garment in service and every 180 days after that, which coincides with every second life preserver calendar inspection. The calendar inspection is also done whenever a discrepancy is discovered during preflight inspection. This inspection consists of the preflight inspection items and the following additional tasks:

You will be required to perform a leak test and repair any discrepancies found after you complete the leakage test.

To perform the leakage test on a CSU-15/P anti-g garment, you should use a special test fixture, which inflates the suit and measures the inside pressure. You are required to inflate the g-suit to 5 psi. The bladder must not drop more than 1.0 psig in 30 seconds. A pressure drop greater than 1.0 psi in 30 seconds constitutes a failure. The CSU-15/P anti-g garment remains in service until it fails the leakage test.

If everything is in order, date and sign the history card.

MAINTENANCE

Repairs are performed at the lowest level of maintenance possible. They are limited to repairing small holes and tears in the outer shell and replacement and adjustment of lacings. Since the hose is part of the bladder system, repairs to it are limited to tightening or replacing the clamp and replacement of quick-disconnect fittings.

Cleaning is performed at the lowest maintenance level possible. To clean the CSU-15/P anti-g garment, proceed as follows:

1. Seal the air inlet port with a cork or a rubber stopper. Do NOT allow water to enter the bladder. NEVER machine-wash or dry clean the anti-g coveralls.

2. Immerse the garment in a solution of bacteriostatic detergent and cold water. Do not wash the garments in hot water. Mix the detergent according to the instructions printed on the container. If

instructions are not printed on the detergent container, use a ratio of 1 cup detergent to 3 gallons of water. Allow to soak for 5 minutes. Agitate gently (by hand) for 2 minutes and drain the water.

3. Rinse in cool, fresh water, and then drain the water. Repeat the rinse process until all traces of detergent have disappeared from the rinse water.

4. To dry the garment, it is very important that you do not try to wring, tumble, or spin dry the garment. This action could damage the bladder or air inlet port. The proper procedure for drying is to hang the garment on a wooden hanger in a dry, well-ventilated area. Do not dry them in direct sunlight because ultraviolet radiation can weaken the fabric.

INTEGRATED TORSO HARNESSES

The MA-2 integrated parachute-restraint harness (fig. 4-13), also known as the integrated

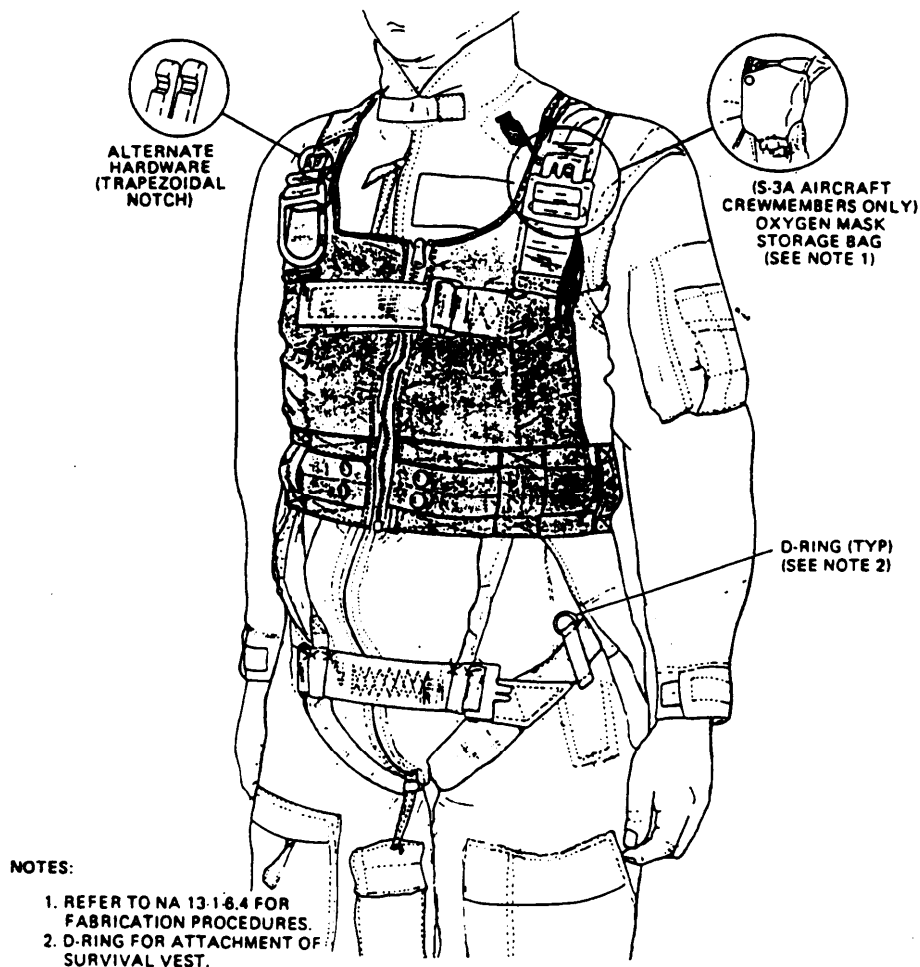

Figure 4-13.-MA-2 torso harness suit (cutaway).

239.397

torso harness suit, integrates the aircrew member's parachute harness, lap belt assembly, and shoulder restraint harness. The parachute harness is reeved through the torso suit to retain it in a position to make it easier to put on and take off. The MA-2 suit provides optimum mobility to the aircrew member while restraining him to the seat during emergency conditions; it serves as a parachute harness in case of aircraft ejection or bailout .

The MA-2 suit consists of a nylon webbing harness encased in nylon fabric, and is configured into a sleeveless, legless, torso garment available in 16 sizes, extra small to extra-extra large long. Shoulder restraint adjustable straps with quick-release fittings provide attachment of the parachute riser assembly. A lap belt with a quick-release adapter is attached to the lap belt alignment webbing. The lap belt assembly provides attachment to a survival kit or parachute and prevents damage to the abdominal area during parachute deployment. The suit is closed by a slide fastener with hooks and eyes for alignment. An adjustable chest strap provides the final necessary chest restraint adjustments. The chest strap is secured by a friction adapter and hook and pile tape. A gated D-ring is attached to the right shoulder adjustable strap near the quick-release fitting. The D-ring is for attaching a helicopter rescue hook.

The MA-2 (cutaway) is approved for use and is fabricated from an MA-2 by cutting away nonstructural nylon cloth. This is done to improve comfort in warmer climate operations and does not decrease either function or reliability of the assembly. The MA-2 (cutaway) is modified at the discretion of the individual aircrew member.

The MA-2 is worn by aircrew members that are fitted with a parachute designed for use with the integrated system.

SIZING

The MA-2 restraint harness should fit the aircrew member properly to provide maximum protection and comfort. The proper size harness must be identified and the fit of the selected size must be observed. Also, the fit must be made with the aircrew member in the ejection seat to be sure that optimum restraint is provided. Finally, the aircrew member will be suspended in the harness and the distribution of weight and body shift will be looked at.

Select an initial harness size from the range of stock sizes by looking at the body build and

height of the aircrew member. A larger or smaller size harness is tried until the best fit is found. Aircrew members unable to be fitted with a stock harness should be considered for a custom-fit harness. Instructions for obtaining a custom-fit harness can be found in NAVAIR 13-1-6.2, and by contacting the Naval Weapons Center (NWC), China Lake, California. Consult the local physiology unit to determine if a custom harness is necessary.

FITTING

With the aid of a flight surgeon (if available) or naval aviation physiologist, you should proceed as follows:

1. Have the aircrew member put on the torso harness. Ensure that the main sling saddle is under the buttocks.

2. Check the location of the male Koch fittings. The optimum location of the male Koch is in the cavity/hollow below the clavicle (collar bone) when the aircrew member is standing or sitting.

3. Adjust the main sling webbing (it is that portion of the main sling located between the leg strap and the chest strap), as shown in figure 4-14; it should be flush to the torso with no bulging or surplus webbing evident. This condition should exist when standing, sitting, or in a hanging position.

4. Ensure that the chest strap does not cross the torso above the armpit when the aircrew member is standing or suspended; it should not be below the breast of the female aircrew member.

5. Inspect the diagonal back strap D-rings (fig. 4-14), and assure that they are positioned in the same horizontal plane and equally spaced from the center of the back.

6. When the aircrew member has completed the final adjustment of the harness, the cinch straps are adjusted to a snug position.

With the aircrew member wearing his/her own flight helmet, suspend him/her a few inches above the deck using a riser assembly with a 12-inch cross-connector strap. Inspect the chest strap, main sling, diagonal back strap adjustable links, and main sling saddle for proper position. Observe closely the aircrew member's weight distribution in the harness. The main sling saddle, when properly positioned, supports the body weight much like sitting in a swing. Weight stress is carried from the main sling saddle up through

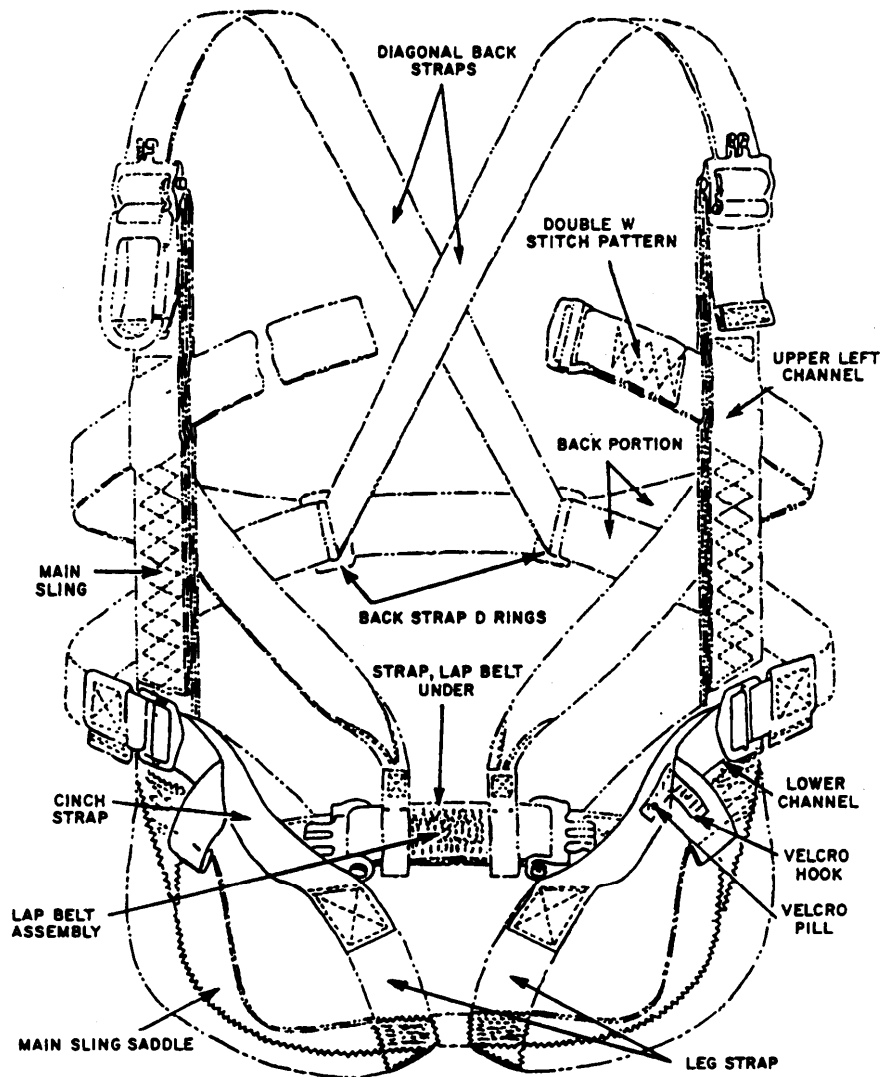

239.398

Figure 4-14.—MA-2 torso nomenclature.

the main sling to the canopy release fittings and riser assembly. Observe that when suspended, the aircrew member's body has not shifted out of the main sling saddle.

LAP BELT AND SHOULDER ADJUSTMENTS

To make the lap belt and shoulder harness adjustments, the aircrew member must sit in an ejection seat. Connect the lap belt fitting and adjust the lap belt until it is snug. Leave no slack in the lap belt. If the lap belt has been completely adjusted to the stop and slack remains, try a smaller harness. If this does not work, the aircrew

member is considered a candidate for a custom-fit harness.

The canopy release/riser/shoulder restraint system must be connected. With the aircrew member sitting upright, shoulders back, there should be no slack in the shoulder harness restraint. If the shoulder harness is fully retracted and there is slack, adjust the torso harness Koch fitting down until slack is removed.

Personnel whose prescribed torso harness does not meet the above criteria will be further evaluated in other size MA-2 harnesses, if appropriate.

INSPECTIONS

There are two inspections that are performed on the MA-2 torso harness—the preflight check and the calendar or initial issue inspection. The MA-2 preflight check is done before each flight and at intervals not to exceed 2 weeks. This check is to be performed by the aircrew member. The other inspection is a calendar or initial issue inspection. The MA-2 torso harness must be inspected upon initial issue and at intervals coinciding with inspection of personal issue protective equipment (i.e., life preserver, helmet, etc.). These inspections consist of the following:

NOTE: Before you perform any inspection on the torso harness, you must determine if the harness is overaged. You would be wasting your time to perform an inspection and then find out that the harness isn't fit for service because of being overaged.

1. Check the harness for its service life by first checking the date of its manufacture. This date is located on the inside of the right front leg strap. The service/total life of the torso harness is 12 years from when it was placed in service, or 15 years from the date of manufacture, whichever occurs first. When an assembly reaches its service life limit, remove it from service and forward it to supply for disposition. If the torso harness hasn't reached 15 years from date of manufacture, you still have to check the service life. The date the torso harness was placed into service is stenciled in the center of the lap belt strap on the outer surface. Whenever an in-service MA-2 lacks the stenciled start of service date, its service life expires 12 years from its date of manufacture. Now you are ready to perform a calendar inspection.

2. Check the chest strap friction adapter for corrosion, distortion, cracks, presence of the locking bar, sharp edges, and security of the attachment.

3. Inspect the shoulder canopy release fittings for corrosion, distortion, presence of the locking bar, absence of sharp edges, proper routing of the webbing, and security of the pin and locking screw. Ensure that the slot head screw is installed and the red lacquer tamper dot is intact.

4. Inspect the lap belt quick-release adapter for corrosion, distortion, sharp edges, and security of attachment.

5. Check the adjustable links located at the rear inside of the suit for corrosion, distortion,

cracks, and sharp edges. Ensure that the chest strap webbing is routed through these links.

6. Check the entrance slide fastener for corrosion, missing teeth, presence of sliders (single slider on the MA-2 cutaway modified), security of attachment, and ease of operation.

7. Inspect the eyes and hooks at the entrance for damage and security of attachment.

8. Inspect the gated D-ring or V-ring at the right shoulder for corrosion, distortion, cracks, and sharp edges.

9. Check the life preserver retention strap for cuts, rips, frayed or weakened webbing, security of stitching, and presence and condition of snap fasteners.

10. Inspect the fabric panels for cuts, tears, fraying, deterioration, and security of stitching.

11. Inspect the harness webbing for cuts, tears, fraying, deterioration, and security of stitching.

12. Repair any discrepancies and update the MA-2 configuration in accordance with procedures outlined in NAVAIR 13-1-6.2.

General repair on the MA-2 consists of replacement of the hardware and repair of cloth. Do not replace any hardware that requires restitching of the harness webbing. Harnesses that are damaged must be discarded.

For more detailed information concerning repairs and modification to the MA-2 and cutaway modified torso harness suits, refer to NAVAIR 13-6-1.2.

HELMETS

The wearing of protective helmets while flying in Navy aircraft depends upon the designation of the aircraft. You will find that aircraft such as fighters, attack planes, and helicopters usually require aircrew members to wear a protective helmet during takeoff, in flight, and landing. Other aircraft may require that the helmet be worn only during takeoff and landing.

The Navy headgear for an aircrew member is considered to be a pilot's protective equipment. Maintenance and upkeep is the responsibility of the Aircrew Survival Equipmentman.

There are a number of different types of headgear. Each has its own specific function. As you work with the different types, you'll find that with very little effort, you can change their basic

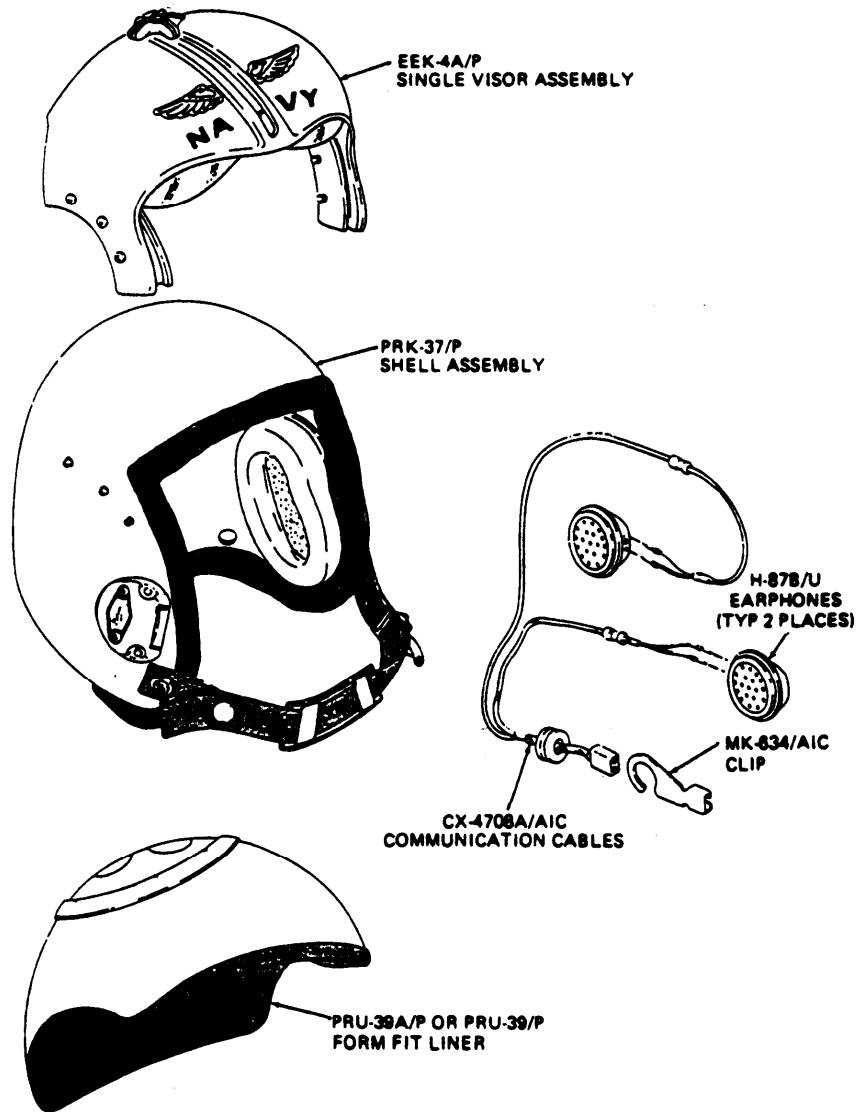

239.413

Figure 4-15.-HGU-33/P helmet assembly.

configuration to meet requirements for all fixed-wing aircraft.

The helmet assemblies in current use are designated as the HGU series. These lightweight helmet assemblies are designed to provide face, eye, aural, and head protection when properly assembled and fitted to the aircrew member. The helmet assemblies also house the headset communications. Some helmet configurations offer specialized features such as VTAS (Visual Target Acquisition System), laser protective lenses, sonar operator binaural cables, and boom microphones. This series of helmets is based on one type of helmet shell, the PRK 37/P.

MAJOR HELMET ASSEMBLIES

By taking the basic shell assembly, PRK-37/P, and adding different liners, visors, and communication systems (fig. 4-1 5), you can make 15 different helmet configurations.

HGU-33/P HELMET ASSEMBLY. The HGU-33/P is a single lens, form-fit helmet for use in aircraft where an oxygen mask is used exclusively.

HGU-34/P HELMET ASSEMBLY. The HGU-34/P is a single lens, pad-fit helmet required

for use in aircraft where an oxygen mask is used exclusively. This helmet assembly is also an interim backup for the HGU-33/P when a form-fit liner cannot be fabricated.

HGU-43/P HELMET ASSEMBLY. The HGU-43/P is a dual lens, form-fit helmet incorporating a neodymium laser protective lens for use in A-6 target range acquisition multisensory (TRAM) aircraft.

HGU-44/P HELMET ASSEMBLY. The HGU-44/P is a dual lens, form-fit helmet used in aircraft where an oxygen mask is used exclusively.

HGU-45/P HELMET ASSEMBLY. The HGU-45/P is a dual lens, form-fit helmet for use in OV-10A aircraft where an oxygen mask and boom microphone are both used.

HGU-45A/P HELMET ASSEMBLY. The HGU-45A/P is a dual lens, form-fit helmet incorporating a neodymium laser protective lens for use in the OV-10D aircraft where an oxygen mask and boom microphone are both used.

HGU-46/P HELMET ASSEMBLY. The HGU-46/P is a form-fit helmet incorporating the VTAS (Visual Target Acquisition System) visor assembly for use in the F-4 VTAS aircraft.

HGU-47(V)1/P HELMET ASSEMBLY. The HGU-47(V)1/P is a single lens, pad-fit helmet required in aircraft where a boom microphone is used or where a boom microphone and oxygen mask are used interchangeably.

HGU-47(V)2/P HELMET ASSEMBLY. The HGU-47(V)2/P is a single lens, pad-fit helmet incorporating a boom microphone without amplifier and the CX-13155/A communication cable for use in C-1A and C-2A aircraft.

HGU-47(V)3/P HELMET ASSEMBLY. The HGU-47(V)3/P is a single lens, pad-fit helmet incorporating a boom microphone without amplifier and the CX-13164/A communication cable for use in T-34 aircraft.

HGU-47(V)4/P HELMET ASSEMBLY. The HGU-47(V)4/P is a single lens, pad-fit helmet incorporating a boom microphone without amplifier and the CX-4832A/AR communication cable for use in P-3 aircraft.

HGU-49/P HELMET ASSEMBLY. The HGU-49/P is a single lens, form-fit helmet incorporating a boom microphone and CX-13128/A communication cable for use in S-3A aircraft.

HGU-50/P HELMET ASSEMBLY. The HGU-50/P is a single lens, form-fit helmet incorporating a binaural headset required for use in the aft stations of the EA-3B aircraft.

HGU-52(V)1/P HELMET ASSEMBLY. The HGU-52/P is a single lens, form-fit helmet incorporating a boom microphone and CX-13155/A communication cable for use in A-3 aircraft.

HGU-52(V)2/P HELMET ASSEMBLY. The HGU-52(V)2/P is a dual lens, form-fit helmet incorporating a boom microphone and CX-13155/A communication cable for use in E-2 aircraft.

MAJOR HELMET COMPONENTS

The following helmet components are available to achieve the desired configuration for the aircrew member helmet.

PRK-37/P HELMET SHELL ASSEMBLY. The PRK-37/P helmet shell assembly is intended to protect the head during in-flight buffeting and emergency situations such as ejection, bailout, or crash landings. It resists projectile penetration and distributes impact forces over the entire head. The helmet shell is the platform for other components such as the visor assembly, communication devices, and the oxygen mask.

PRU-39/P HELMET SHELL LINER ASSEMBLY. The PRU-39/P is a helmet shell liner that is a form-fit, foam-in place type assembly, which is installed in the PRK-37/P helmet shell assembly. The PRU-39/P consists of a rigid polyurethane foam liner molded to fit the aviator's head. The KMU-439/P (liner mold kit) is positioned on the pilot's head, and foam chemicals are injected into it. The liner is finished with a soft urethane foam comfort pad and leather covering. When properly fitted, the liner provides impact energy absorption, helmet stability, and comfort.

PRU-39A/P HELMET SHELL LINER ASSEMBLY. The PRU-39A/P is a helmet shell

liner that is form-fit and constructed from one-ply fiberglass backing (contour-molded to fit within the PRK-37/P helmet shell), a leather covering, and a comfort pad. The leather covering and comfort pad are cemented to the fiberglass backing. The fiberglass backing has two holes for introduction of foam chemicals. When properly fitted, the liner absorbs impact energy and makes the helmet stable and comfortable. The aircrew member wears a perspiration-absorbing cotton skull cap to extend the life of the liner.

PRK-40/P HELMET SHELL LINER ASSEMBLY. The PRK-40/P helmet shell liner, which comes in two sizes and consists of a premolded 1/2-inch thick polystyrene foam liner, is molded to fit inside the PRK-37/P helmet shell assembly. Final fitting of the PRK-40/P is accomplished by a series of different fitting pads. Also included in the assembly is a nape strap to allow a snugger fit. When properly fitted, the liner is designed to provide impact energy absorption, helmet stability, and comfort.

EEK-4A/P HELMET VISOR, SINGLE LENS. The EEK-4A/P is a single lens helmet visor assembly. When installed on the helmet shell, it protects the face and eyes from impact, projectile penetration, sun glare, dust, windblast, and fire. Each assembly comes with interchangeable clear and neutral lenses.

PRU-36/P HELMET VISOR, DUAL LENS. The PRU-36/P is a dual lens helmet visor assembly, which provides the aircrew member with the same protection as the EEK-4A/P.

EEK-3/P HELMET VISOR, DUAL LENS. The EEK-3/P is a dual lens helmet visor assembly, which gives the aircrew member the same protection as the EEK-4A/P. Each assembly comes with a neodymium laser protective inner lens and an interchangeable clear and neutral outer lens.

R-1825/AVG-8, R-1826/AVG-8 HELMET VISORS. The R-1825/AVG-8 mounts on a large size helmet shell while model R-1826/AVG-8 mounts on a medium. The receiver includes a parabolic visor, which provides the pilot with a collimated reticle image. Two sensor electronic assemblies, one mounted in each side of the receiver housing, assist in converting the pilot's line of sight into aircraft coordinates. The main assemblies of the receiver

are the housing, the visor assembly, and the harness assembly.

COMMUNICATION CABLE ASSEMBLIES. Each of the helmet assemblies is outfitted with the appropriate communication components for operation with aircraft ICS (Intercommunication System).

M-87/AIC BOOM MICROPHONE ASSEMBLY. The boom microphone assembly provides communication when the oxygen mask is not in use, as well as walkaround capabilities.

NOTE: Detailed information on the fabrication of the form-fit liners can be found in the NAVAIR 13-1-6.7.

SIZING THE PRK-37/P

When building up the HGU pilots protective helmet, it is very important that you start with the proper size helmet shell (PRK-37/P). The PRK-37/P is available in four sizes, (medium, medium/large, large, X-large). To determine the proper size, you must first measure the circumference of the head, at the hatband line, with a tape measure. Once you have the correct measurement, you can determine the equivalent helmet size by referring to table 4-3.

HELMET CONFIGURATION BUILDUP

Once the basic PRK-37/P helmet shell and major components are received, carefully inspect the shipping containers for evidence of damage or signs of abuse. Open each container and verify that all the required items have been included. If any parts are defective, damaged, or missing, replace all items in the shipping container, prepare a Deficiency Investigation Report, and notify the proper authority. Once the helmet shell and related components have been accepted, the shell may be built up by adding or removing major components in order to obtain the desired configuration for required aircrew or aircraft application. Before you attempt to build up the helmet, it is necessary to follow the steps outlined in the NAVAIR 13-1-6.7 for each major component you are installing.

MAINTENANCE

As with all equipment that you work with and maintain, proper care of the fixed-wing series

Table 4-3.—PRK-37/P Helmet Shell Sizing Guide

CIRCUMFERENCE (SEE NOTE 1)	COMPARABLE HAT SIZE	SHELL AND LINER SIZE REQUIRED	PART NUMBER (FSCM)
21	6 3/4	Medium	954AS300-1 (FSCM30003)
22	7	Medium	954AS300-1 (FSCM 30003)
23	7 1/4	Medium/Large (SEE NOTE 3)	
24	7 1/2	Large	954AS300-2 (FSCM 30003)
24 1/2	7 3/4	Large	954AS300-2 (FSCM30003)
25 or more	7 7/8 or more	X-Large (SEE NOTE 2)	79D444-7 (FSCM 97427) or (FSCM 92114)

NOTES:
1. Circumference dimensions in inches.
2. Available through direct procurement from the manufacturer.
3. Whenever possible, the aircrewmembers are fitted with a medium size helmet.

helmet assemblies is essential to ensure optimum performance during emergencies and routine flights. The aircrew member is responsible for cleaning and proper handling of the helmet. All repairs and modifications are done by the PR at the organizational maintenance level or above.

Cleaning

You must clean all parts of the helmet at least every 90 days. To clean the shell and edge roll, use mild detergent and water. Sometimes you may have to use a mild abrasive scouring powder to remove stains or scuff marks. The chin strap, nape strap, and fitting pads may be cleaned by lightly sponging with a solution of detergent and water. The skull cap may be laundered in a machine, but this is the responsibility of the aircrew member.

The visor assemblies are probably the most important parts that require cleaning. If you have ever worn sunglasses and they became dirty, you know how aggravating that can become. By using a solution of mild soap and water and a soft cloth, you can clean most visor's lenses. Rinse off the solution and allow to dry. If lenses are still

soiled or slightly scratched, clean the outside visor only with liquid canopy polish. The inside of the visor must be cleaned with a soft, lint-free cloth. After cleaning, apply an antifog solution.

Addition of Reflective Tape

The addition of reflective tape on the helmet provides for improved detectability of the downed aircrew member. The tape must be affixed to all helmets. However, in combat areas the tape may be removed, as the crew commander directs. White and red reflective tapes are recommended, as they afford the greatest detectability. When applying the tape, you use any pattern specified by the unit commander, as long as the tape pattern covers a minimum of 100 percent of the helmet visor housing and outer shell.

To apply the tape, you should preheat both the helmet and the tape to approximately 100 °F. This improves the adherence qualities and ease of application.

Aviator helmets should be taped in accordance with the provisions of chapter 7 of OPNAVINST 3710.7 (series) (general NATOPS) and any type commander directives.

INSPECTIONS

There is one basic inspection that you must perform on the helmet—the calendar inspection. In addition, the aircrew member is responsible for a preflight/postflight inspection before and after each flight.

Calendar Inspection

The calendar inspection is conducted by organizational-level activities upon issue and every 90 days thereafter. The 90-day inspection consists of a visual inspection, functional check, and a thorough cleaning.

NOTE: Every other calendar inspection, or every 180 days, the chin strap, nape strap pad, ear seals, and skull cap must be replaced.

Visual Inspection

To visually inspect the helmet, you must make a thorough sight inspection for broken parts, security of attached parts, loose or broken stitchings, and also inspect the earcups for sound attenuation and pliability.

Functional Check

The functional check is performed with the aid of a REDAR oxygen hose test set. If this unit is not available, standard shop procedures should be performed. Refer to NAVAIR 17-15BC-7 for the proper testing sequence.

SPH-3C HELMET

The SPH-3C helmet, shown in figure 4-16, is designated for use by all helicopter aircrew members.

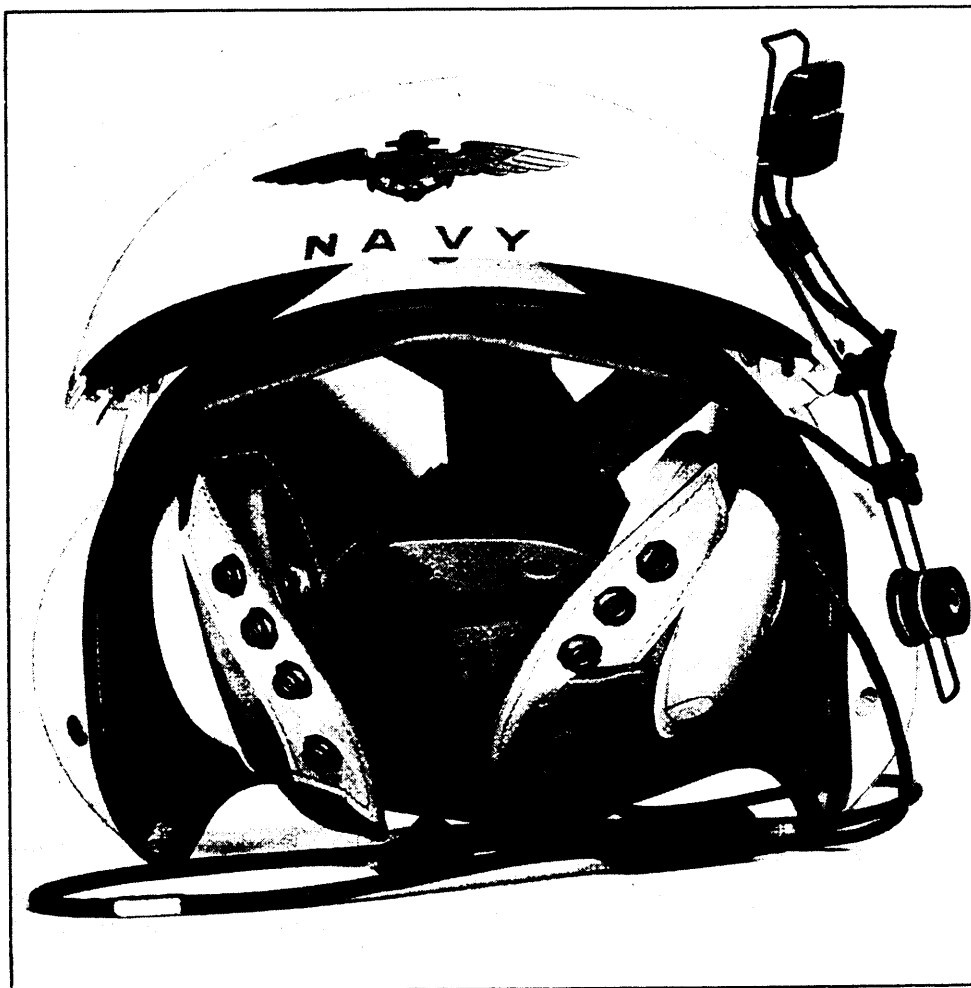

Figure 4-16.—SPH-3c protective helmet.

239.319

The SPH-3C helmet protects the wearer's head during in-flight buffeting or crash landings. It is designed to distribute impact forces over the entire head, and to absorb these forces so that a minimum amount of impact reaches the wearer's head. The SPH-3C helmet is supplied in two sizes, regular and extra large. The helmet consists of an outer shell assembly, an inner foam liner, sizing liner, inner cloth liner assembly, dual integrated visor, communication cord set, and a microphone adapter.

The outer shell assembly is fabricated from Kevlar and polyester resin, and it provides impact and penetration protection. An edge roll, made of neoprene foam, provides protection from the helmet edges.

The inner foam liner is made of cellular polystyrene sheets molded to fit the inside contour of the outer shell. The liner is provided to absorb and dissipate impact forces.

The sizing liner, which is optional, aids in fitting the helmet to the aircrew member's head contour by padding the helmet at the nape of the neck.

Sizing liners are provided in 1/4-, 1/2-, and 5/8-inch sizes.

The inner cloth liner assembly includes the sonic earcup assemblies and foam pads for sizing and comfort; it also has adjustable crown and nape straps.

The dual integrated visor provides protection from sun glare, dust, windblast, foreign particles, and flash fires. The visors are protected by a molded fiberglass housing when not in use. Two visors, clear and neutral, are available. The percentage of visible light transmittance of the neutral visor is 8 to 16 percent. The percentage of light transmittance of the clear visor is 87 percent or greater.

The communications cord set connects the aircraft communications system to the helmet earphones. The microphone adapter, located on the helmet, allows attachment of a boom-type microphone.

Fitting

The SPH-3C protective helmet must be individually fitted to the aircrew member. For maximum protection, comfort, and sound attenuation, a good fit is a snug fit at the cheeks, forehead, and nape of the neck. A loose fitting helmet is more apt to produce pressure areas and discomfort.

If the helmet moves independently of the head, readjust the sizing liners, spacers, and adjusting straps. If necessary, file and sand the nose

indentation to fit the contour of the aircrew member's nose. Ensure that the visor at the nose indentation is free of nicks and roughness.

Maintenance Procedures

Minimal maintenance, which is cleaning the visor and outer shell, can be performed by the aircrew member as needed. All other maintenance operations must be performed upon issue and at least every 90 days thereafter by qualified personnel at the lowest level of maintenance possible.

Inspect the sizing liners and inner foam liner for looseness, re-cement where applicable, and replace worn or torn sizing liners. Inspect the shell assembly for cracks, dents, scratches, splits, and delamination. Inspect all hardware for damage and security of attachment, tighten or replace hardware as necessary. Inspect straps, communications cord set, earphones, and dual visor assembly for damage. Replace parts as necessary.

The visor may be cleaned with mild soap and water and dried with a soft, clean cloth. To remove minor scratches or remaining soiled areas, use acrylic plastic polish.

To preserve the visor's plastic surface, use polishing wax for the final application. Do not use solvent or abrasive-type cleaners.

OXYGEN MASKS

The oxygen mask is the final link in conveying oxygen from the aircraft system to the user. A 'satisfactory regulator and oxygen system or a full cylinder' of oxygen is of little value to a pilot if his oxygen mask is not operating properly in every respect.

The oxygen mask is the pilot's personal equipment; that is, after initial fitting, they are retained by the individual. Fitting, adjustments, maintenance, cleaning, and incorporating modifications are the responsibility of the PR.

The important factor to remember about identifying any oxygen mask is its compatibility with the oxygen system with which the mask is to be mated.

PRESSURE-DEMAND OXYGEN MASK MBU-12/P

Oxygen mask assemblies are designed to be worn over the face, forming a seal to the cheeks over the bridge of the nose and under the chin. The mask is designed for use with a regulator, which provides breathing gas (100-percent oxygen or oxygen diluted with air) upon demand at a pressure schedule dependent on the altitude. The mask can also be used with continuous-flow

bailout or walkaround oxygen sources. The mask also provides facial protection from projectiles and fire, as well as working at depths of 16 feet underwater. A properly fitted oxygen mask is also essential to helmet retention in high-speed ejections. The facepiece permits utilization of the valsalva maneuver to clear clogged sinuses by holding your nose with your mouth shut and trying to exhale. Then open your mouth wider. This operation will clear most sinus cloggings.

The MBU-12/P pressure-demand O₂ mask is the basic mask used to configure any of the following oxygen mask assemblies:

- | | |
|--------------|---------------|
| MBU-14(V)1/P | MBU 16/P |
| MBU-14(V)3/P | MBU 17(V) 1/P |
| MBU 15/P | MBU 17(V)2/P |

Information on each assembly can be found in NAVAIR 13-1-6.7. Figure 4-17 shows a MBU 12/P configured into a MBU 14(V) 1/P.

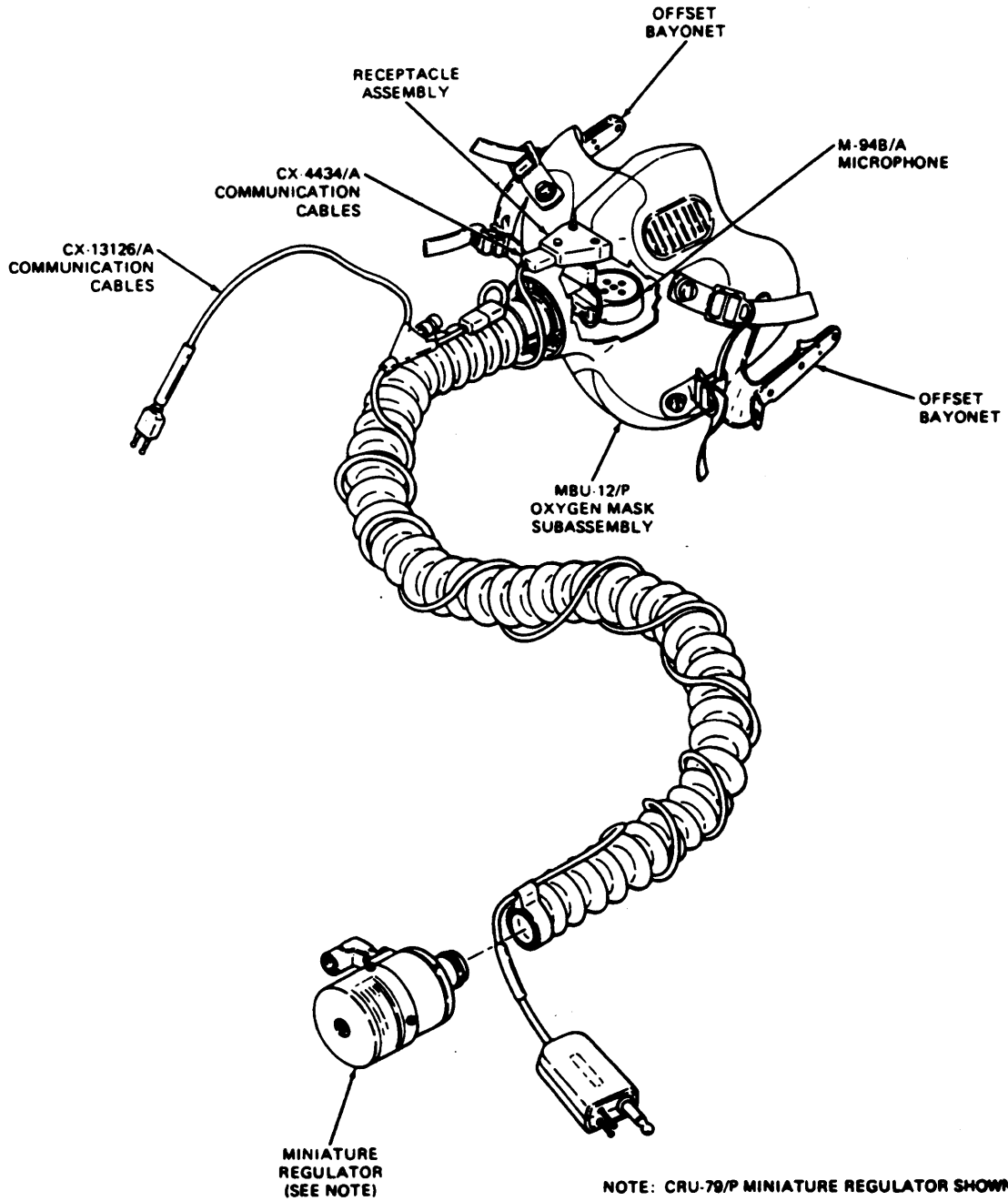

Figure 4-17.—MBU-14(V)1/P oxygen mask assembly.

239.414.1

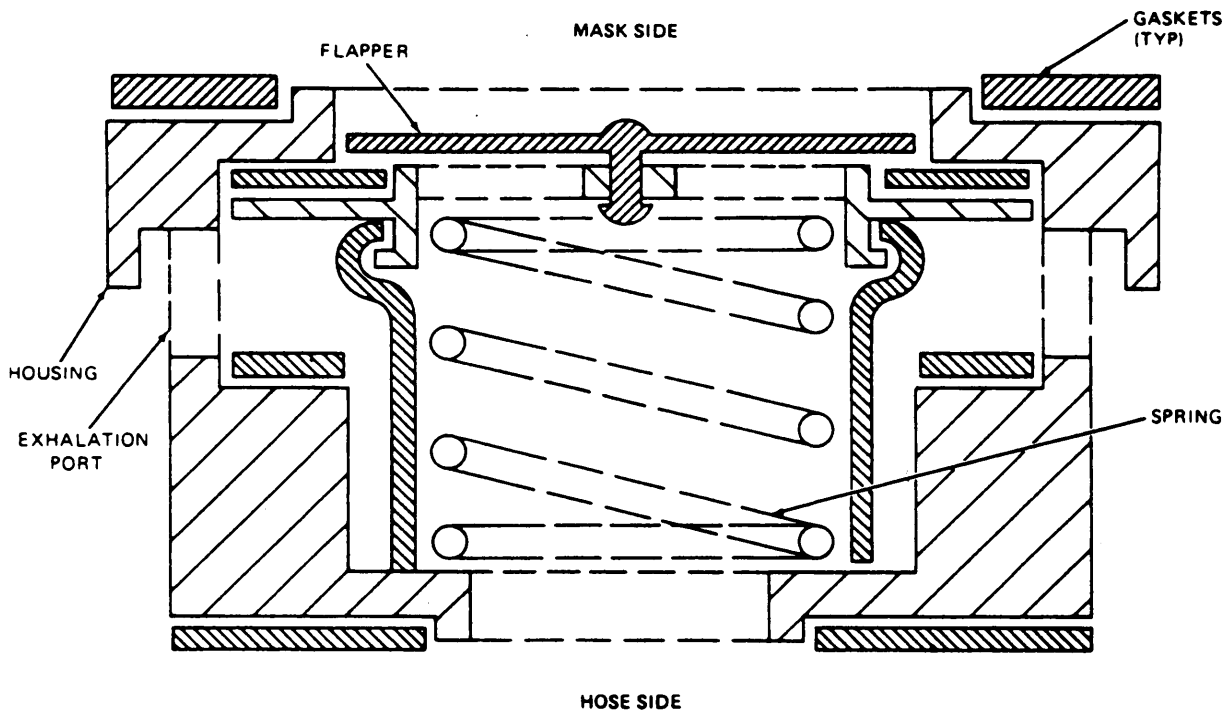

Figure 4-18.—Cross-sectional view of a combination inhalation/exhalation valve.

239.415

The MBU-12/P oxygen mask subassembly is a lightweight, low profile, pressure-demand type of oxygen mask. The mask features an integral facepiece/hard shell. The facepiece is of pliable silicone and the hard shell is of polysulphonate. The mask also features a combination inhalation/exhalation valve, a flexible, soft silicone hose, and an MS27796 connector. The mask is fitted with an antistretch cord, which is secured at the upper end to the valve and at the lower end to the MS27796 connector. The hard shell is outfitted with a microphone receptacle assembly on the outside and a microphone bracket on the inside for positioning the noise canceling microphone.

Combination Inhalation/Exhalation Valve

The valve offers the advantage of miniature size, but it does exhibit slightly higher exhalation resistance. The valve is sensitive to both dust and contamination. As a PR, you are responsible for cleaning the mask.

Operation of the valve is very simple. The valve is installed in the mask hard

shell in such a way that one side of the valve “sees” mask pressure and the other side “sees” hose pressure (fig. 4-18). Upon inhalation, the pressure within the mask becomes less than the pressure within the oxygen hose; the flapper of the valve opens and oxygen from the hose enters the oxygen mask (fig. 4-19). Upon exhalation, the pressure within the mask becomes greater than the pressure within the hose; the flapper closes; the spring/diaphragm collapses; and the exhalation is exhausted (fig. 4-20).

Sizing

To operate properly, the MBU-12/P oxygen mask must be the correct size for the aircrew member. The concept of sizing as used here refers to the basic methods to be followed by the Aircrew Survival Equipmentman for requisitioning the proper size oxygen mask assembly from supply. Once the basic oxygen mask size has been determined and requisitioned, the MBU-12/P oxygen mask is ready for buildup to the ultimate configuration desired. To select the proper size, use the caliper shown in figure

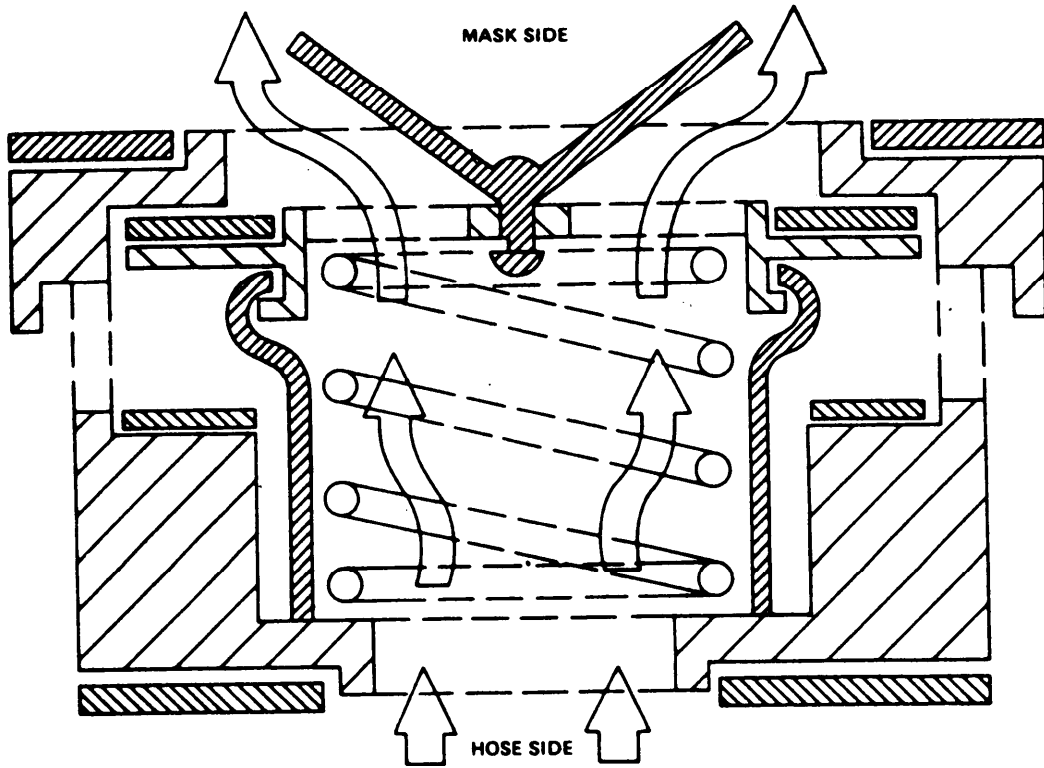

239.416

Figure 4-19.—Cross-sectional view of valve during inhalation.

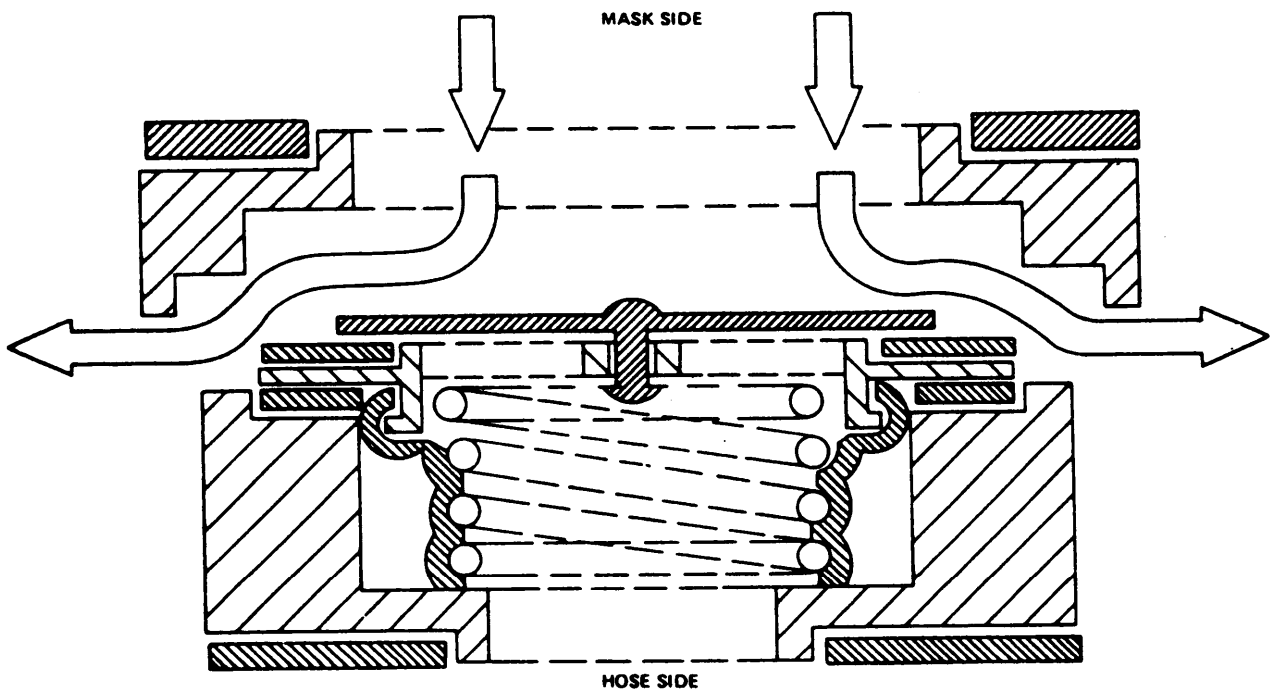

239.417

Figure 4-20.—Cross-sectional view of valve during exhalation.

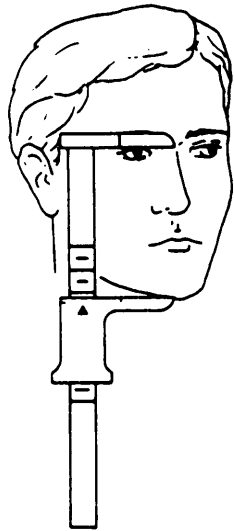

NOTE: HOLD CALIPER AS SHOWN ABOVE TO READ MBU-12/P MASK SIZE. OPPOSITE SIDE INDICATES MBU-5/P SIZES AND IS NOT TO BE USED.

Figure 4-21.—Measuring for proper size of O₂ mask.

4-21; measure the distance from the tip of the bottom surface of the chin to the point of maximum depression of the nasal root (smallest part of the upper end of the nose). Once the basic size has been determined, requisition a new mask through normal supply channels.

ATTACHMENT OF BAYONET AND RECEIVER MECHANISM

Before you fit the mask to the helmet, you should check to see if the MBU-12/P has been configured to the correct assembly. For complete information on configuration buildup, refer to chapter 13 of NAVAIR 13-1-6.7. Once you have a complete assembly of the right size, you're ready to fit the mask to the helmet.

The mask has four mask retaining straps. You should thread the straps through the slots in the offset bayonet fittings, as shown in figure 4-22. Then insert each offset bayonet fitting into a receiver mechanism to the second locking position. When the bayonet is inserted in the receiver, the first click is caused by the entry of the bayonet into the entrance of the receiver housing, but it is not a locking position. There are normally three clicks when inserting the bayonet to the second locking position of the receiver. When the bayonet is in the second locking position, the end of the bayonet will be approximately even with the outer

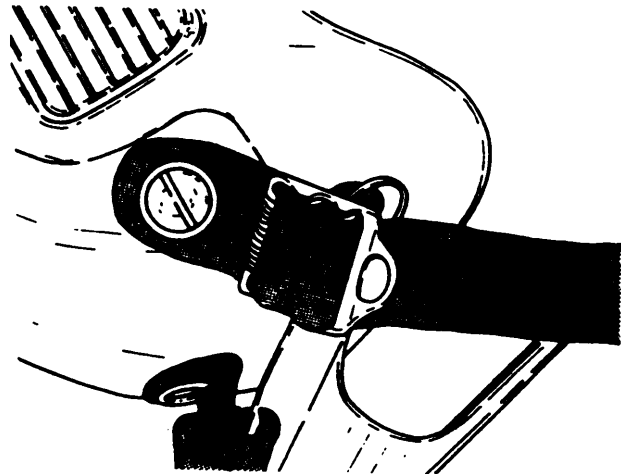

Figure 4-22.—Mask retaining straps.

239.419

edge of the exit slot on the back of the receiver. This proper positioning of the bayonet end can be checked either visually or by passing a finger over the exit slot on the back of the receiver.

Have the aircrew member place the helmet on his head and hold the oxygen mask in proper position on his face.

Inspect each receiver mechanism assembly to be sure that the rotating feature of the device is locked in its central position. If the rotating feature is found not to be centered, loosen the two locking screws on the nameplate of the receiver. Adjust the receiver until the bayonet is at right angles to the receiver. Retighten the locking screws (fig. 4-23).

The receiver has a rotating feature that allows a 15-degree angle of freedom so that the receiver can be adjusted slightly in either direction if this becomes necessary after attachment to the helmet. Place the receiver on the helmet so that the upper and lower straps have equal tension. The receiver should be positioned as close to the edgeroll as possible to minimize bayonet/edgeroll interference.

With a grease pencil, trace around each receiver to mark its outline on the helmet (fig. 4-24). You should use this outline to align the receiver on the helmet. Now remove the helmet from the wearer and using the back plate of the receiver as a template, mark the locations for the four receiver mounting holes on the helmet (fig. 4-25). Remove the earcup assemblies and drill four mounting holes in the helmet. Do this on each side by using a No. 25 (0.1495-inch diameter) drill. It

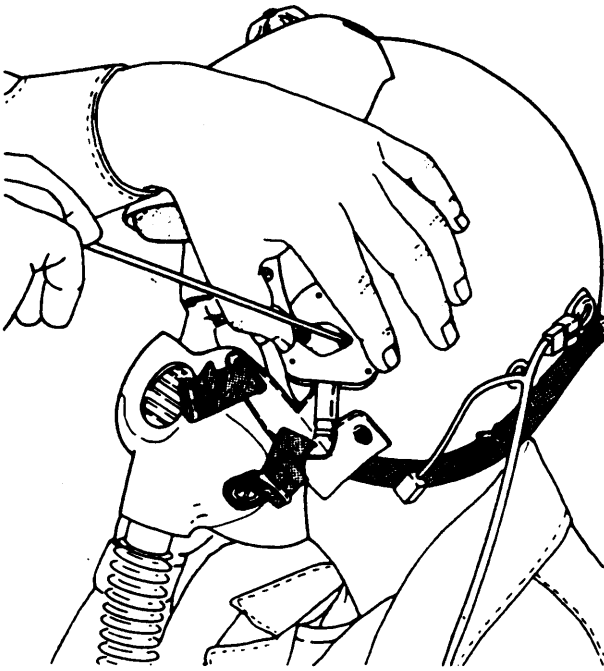

239.420

Figure 4-23.—Adjusting receiver assembly.

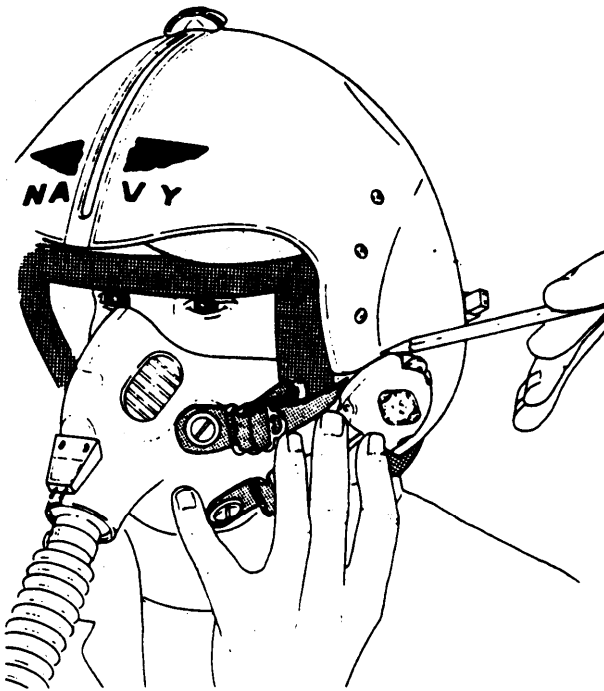

239.421

Figure 4-24.—Marking helmet.

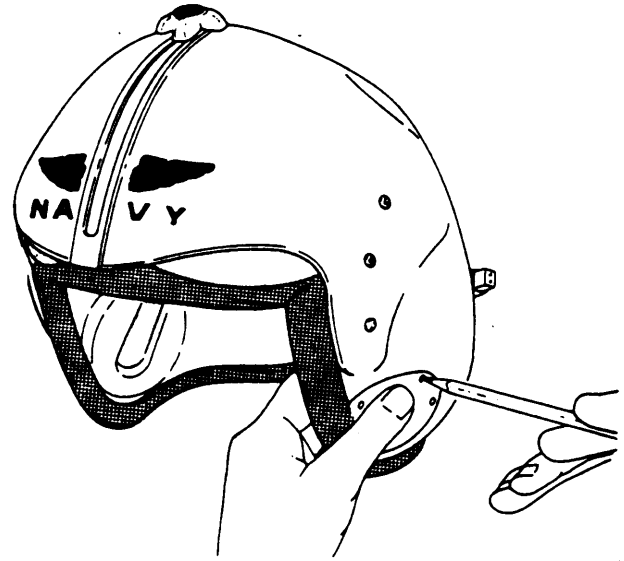

239.422

Figure 4-25.—Marking holes.

is necessary to peel back the pile fastener tape inside the helmet to allow the attachment of the bayonet receivers. Attach the receiver mechanism assemblies to the helmet with the backup plate inside the helmet. Note that the forward receiver holes nearest the edge of the helmet need longer screws. At this time you can replace the pile fastener tape and replace the earcup assemblies. It maybe necessary to use adhesive when replacing the pile tape.

Fitting

The concept of fitting as used here refers to procedures required for necessary component adjustment following oxygen mask assembly buildup. Fitting instructions are provided only as a general guide. Because of the wide variation in facial shapes likely to be encountered, it is not possible to present detailed guidance. A successful fit depends largely on the skill and experience of the Aircrew Survival Equipmentman in selecting and adjusting the oxygen mask assembly to the aircrew member's face. Improperly fitted oxygen masks do not provide a positive face seal for pressure breathing and do not protect the aircrew member in emergency situations.

Have the aircrew member don the helmet, and ensure that the helmet nape strap has been adjusted to a snug fit. Insert each bayonet into

the second locking position of the receiver and adjust the straps until the mask is snug and comfortable. Attach the straps in place with two turns of "E" thread. Perform a functional check on the oxygen mask.

NOTE: If leaks occur between faceform and face, check to see if proper mask size has been issued. If leakage still occurs, adjust helmet bayonet receivers. Refer to table 4-4 for troubleshooting procedures.

Table 4-4.-Troubleshooting

TROUBLE	PROBABLE CAUSE	REMEDY
Leakage from facepiece	Loose fit	Hold mask tighter against face.
		If mask is connected to a flight helmet, tighten straps on strap and buckle assemblies.
	Improper mask size	Use next smaller mask size. Refer to Section 13-1.
Leakage at microphone connector	Loose screws	Carefully tighten screws. Refer to Section 13-7.
	Improper seating or defective microphone bracket	Check mating of microphone bracket with microphone. Refer to Section 13-7.
		Check microphone connector and bracket for damage or cracks. Replace as necessary.
Damaged or misplaced gasket	Replace gasket. Refer to paragraph 13-71.	
Leakage from delivery tube	Loose inlet connection or loose or defective hose clamp	Tighten or secure inlet connection. Refer to Section 13-7.
		Tighten or replace mask hose clamp. Refer to Section 13-7.
	Damaged or deteriorated delivery tube	Replace delivery tube. Refer to paragraph 13-76.
Breathing is difficult or inhalation/exhalation valve sticks	Defective oxygen valve	Replace oxygen valve assembly. Refer to paragraph 13-75.
	Improperly seated valve nut or washers	Check for proper seating alignment of valve assembly. Reseat as necessary
Voice communication difficult or impossible (if microphone is present)	Defective microphone connector or microphone bracket	Replace microphone connector amplifier and/or bracket if necessary. Refer to paragraphs 13-70 and 13-71.
Leakage at strap screw	Defective seal on strap screw	Replace strap screw and tee nut as necessary.

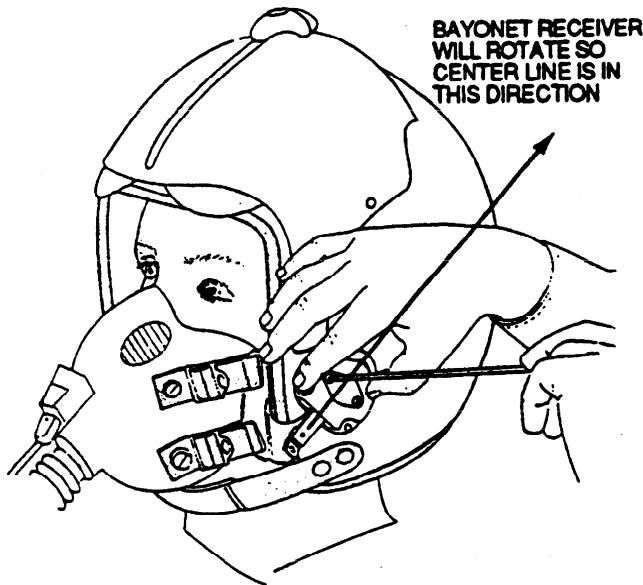

Figure 4-26.—Adjustment of bayonet receivers.

Adjustment of Bayonet Receivers

To adjust the bayonet receivers, loosen the two adjusting screws (fig. 4-26) and rotate the receivers until the mask fits properly. Retighten the adjusting screws.

NOTE: Ensure that the top buckles are tacked down prior to any adjustment.

Adjustment of the bayonet receivers is performed with the helmet assembly and oxygen mask assembly donned by the aircrew member.

When properly fitted, the MBU-12/P oxygen mask can retain a pressure in excess of ambient pressure up to the maximum pressure supplied by the regulator.

Maintenance

Proper care and use of oxygen masks is essential to ensure optimum performance during routine flight operations and emergencies. The aircrew member's responsibility for maintenance of the oxygen mask is limited to cleaning. Repairs or other maintenance actions required are performed at the organizational level or above.

PREFLIGHT/POSTFLIGHT INSPECTION

The preflight/postflight inspection is a visual inspection performed by the aircrew member to

whom the oxygen mask is issued before each flight. The preflight/postflight inspection consists of the following procedures:

NOTE: Defects or questionable areas noted during this inspection must be referred to the proper maintenance activity for required corrective action.

1. Check the communication system and microphone for proper installation.
2. Check the mask for damage and proper operation by using the tester and/or aircraft oxygen and communications system.

Calendar Inspection

The calendar inspection is conducted every 30 days at the organizational level and consists of a visual inspection, a functional check, and a thorough cleaning of the oxygen mask assembly. Refer to NAVAIR 13-1-6.7 for visual inspection and functional check procedures.

NOTE: If a discrepancy is noted, refer to table 4-4 for guidance.

Cleaning Mask

To clean and sanitize the oxygen mask facepiece and housing assembly, proceed as follows:

Preferred solution. Make a 1 percent by weight solution of cleaning compound (Detergent, General Purpose, MIL-D-1 6791, Type I) by adding 1/4 to 1/2 ounce (liquid) of the compound to 1 gallon of water.

CAUTION

WHEN THE FOLLOWING ALTERNATE CLEANING SOLUTION MUST BE USED, ONLY THE LATHER FROM THE SOLUTION IS USED FOR CLEANING. THIS PREVENTS UNDISSOLVED SOAP SOLUTION FROM GETTING INTO THE VALVE.

Alternate solution. Make a suitable soap solution by adding approximately 4 tablespoons of soap powder (P-S-600) to 1 gallon of water. Hardness of water may require more soap, but the solution must be sufficiently strong to readily form lather when agitated. Make sure that all soap particles are dissolved.

CAUTION

ENSURE THAT CLEANING SOLUTION DOES NOT ENTER THE INHALATION/EXHALATION VALVE ASSEMBLY.

Moisten a gauze pad with the cleaning solution and wash the facepiece and housing assembly both internally and externally.

After washing, the mask should be thoroughly and repeatedly rinsed with warm water.

NOTE: Another alternate sanitizer, Aerosol Antiseptic Spray SBT-12 (dibromosalicyl bromanide), manufactured by Lever Brothers, Inc., can be used. Directions for use are indicated on the container.

After all parts are dry, disinfect by using a gauze pad or other lint-free wipers, with a solution of 2 tablespoons of chlorine bleach per gallon of water; rinse with clear water and air dry. Be certain disinfectant reaches inner crevices of the faceform.

To clean the delivery hose, wash it with a cleaning solution and rinse it with clear water. Allow all parts to air dry.

When cleaning the inhalation/exhalation valve assembly, it will be necessary for you to obtain a container just large enough to partially submerge the valve. Fill the container half full of benzalkonium chloride solution, MIL-B-37451, or a solution of 70 percent isopropyl alcohol and 30 percent distilled water.

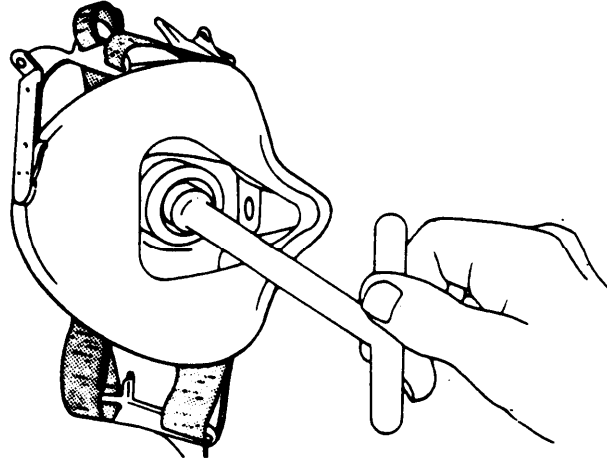

239.423

Figure 4-27.—Removing locking nut.

By using a valve wrench, as shown in figure 4-27, unscrew the valve nut and remove the locking nut, bearing washer, and isolation washer from the inside of the mask. This will allow the valve, sealing washer, delivery tube, and connector assembly to be removed as a unit from the outside of the mask. Hold the base portion of the valve and submerge the operating portion of the valve into the solution. Normally, only a few seconds are required to remove any stains and residue. For stubborn residues, use a cotton swab saturated with benzalkonium chloride and rub lightly to remove. Gently shake excess solution from oxygen valve and allow it to air dry completely.

CHAPTER 5

RESCUE AND SURVIVAL EQUIPMENT

Learning Objective: Upon completion of this chapter, you will be able to recognize, inspect, and maintain survival items and rescue equipment.

When an aircrewman has to leave his aircraft in a hostile environment, survival items provide a means of sustaining life, attracting the attention of rescuers, and aid in evading the enemy. Survival items may be packed in life rafts, droppable kits, and kits intended to be carried or worn by the aircrewman.

As an Aircrew Survival Equipmentman, your responsibility to the aircrewman is to maintain these survival items. You need to know how they work and be able to pass that information on to the aircrewman.

Many of the items that are frequently carried by the aircrewman are discussed in the following text. The ones that are not covered in this chapter are described in the NAVAIR 13-1-6.5 manual.

SIGNALING EQUIPMENT AND DEVICES

The following items are used to attract the attention of a rescue team. With the proper knowledge, ability, and caution, these items can provide invaluable assistance in a survival situation.

DYE MARKER

The dye marker (fig. 5-1) is an aniline dye powder in a sealed container. When placed in the water, it produces a bright color that appears orange or fluorescent green depending on how the light strikes it. It is used to attract the attention of rescue aircraft. The dye is exhausted from the package in 20 to 30 minutes and ceases to be a good target after 1 hour. The dye-exposed water



239.399

Figure 5-1.—Dye marker.

area is visible at an approximate distance of 10 miles from an altitude of 3,000 feet. If rapid dispersion of the dye is desired, agitate the packet of dye vigorously in the water.

SIGNALING MIRROR

The emergency signaling mirror is approximately 3 by 5 inches and consists of an aluminized reflecting glass mirror, a back cover glass, and a sighting device. It is used by personnel in rafts or on land to attract the attention of passing aircraft or ships by reflection, either in sunlight or in hazy weather. The reflections of this shatterproof mirror can be seen at a distance 3 to 5 times as great as those from which a raft can be sighted at sea. On a clear sunny day, the mirror

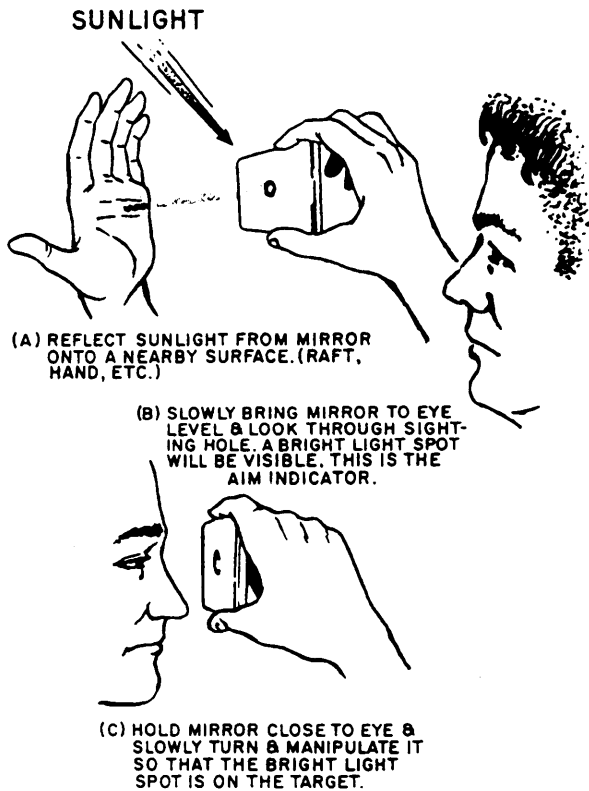

239.340

Figure 5-2.—Operation of the signaling mirror.

reflects the equivalent of 8 million candlepower. Flashes from the mirror have been seen from a distance of 40 miles. A smaller mirror, measuring 2 by 3 inches, is also used in some kits.

Figure 5-2 shows the operation of the signaling mirror. Past experience indicates that personnel may have difficulty using the mirror in a bobbing raft at sea. Signaling practice with the mirror should be encouraged as part of the training program for flight crews. Such practice reduces the difficulty in case of emergencies. Before using the mirror, read the instructions printed on its back.

MK 79, MOD 0 ILLUMINATION SIGNAL KIT

The Mk 79 signal kit is supplied with one pencil-type launcher (Mk 31), seven Mk 80 screw-in cartridges, and a bandolier for storing the flares until use. Protective caps should be used over the primers of the cartridges when not using the bandolier.

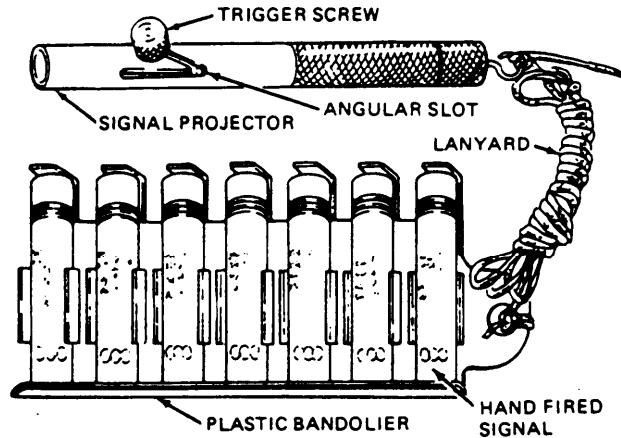

239.400

Figure 5-3.—Mk 79 Mod 0 illumination signal kit.

Each cartridge flare has a minimum duration of 4 1/2 seconds and can be launched up to 250 feet. When the launcher is stored in the survival vest, it should be in the COCKED position and empty (fig. 5-3). Refer to NAVAIR 11-15-7 for proper handling and storage of the signal kit.

MK 13, MOD 0 SIGNAL FLARE

The Mk 13, Mod 0 signal flare is intended to attract the attention of SAR aircraft and to give them drift direction. To avoid being burned by sparks, the ignited Mk 13, Mod 0 signal must be held at arms length and no more than shoulder high. If the Mk 13, Mod 0 signal is being used at sea, hold it over the side of the life raft to prevent damage to the life raft from hot residue. The Mk 13, Mod 0 signal may be put out by dousing in water or snuffing in sand. Refer to NAVAIR 11-15-7 for precautions, handling, and storage procedures.

The Mk 13, Mod 0 consists of a metal cylinder closed at each end. There is a tear friction tape igniter on a clip at each end. One end contains a red flare for nighttime use; the opposite end houses an orange smoke signal for daytime use. Each end of the signal burns approximately 20 seconds. The nighttime end of the flare has protrusions that you can feel in the dark. On the outside of the Mk 13, Mod 0 flare are operating instructions and a lot number (fig. 5-4). The lot number should be checked each time the flare is inspected to ensure that the flare is still serviceable. A list of lot numbers that are not serviceable can be found in current aircrew

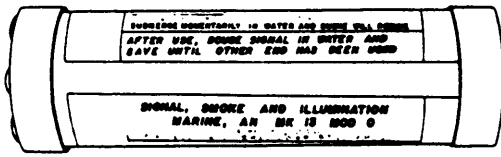

239.401

Figure 5-4.—Mk 13 Mod 0 marine smoke and illumination signal.

equipment bulletins. Any flares manufactured before 1960 should also be removed from service.

DISTRESS LIGHT (SDU-5/E)

The SDU-5/E light equips aircrew members and shipboard personnel with a high-intensity visual distress signal. The infrared filter and blue flash guard, contained in the SRU-31/P survival kit, are used in conjunction with the SDU-5/E light for signaling purposes in combat areas.

The SDU-5/E is commonly called a strobe light. It emits a high-intensity flashing light. This light is visible for great distances at night.

The SDU-5/E strobe light requires an inspection by the PR each time the aircrewman's flight gear is inspected (every 90 days). The aircrewman should perform a daily inspection to ensure that the light is operative. The calendar inspection consists of activating the light for 2 minutes. If the light does not operate at 50 flashes per minute (plus or minus 10 flashes) for the 2-minute duration, replace the battery. Repeat the procedure; if the light still does not operate, remove the light from service.

You must perform this test both in total darkness and also in a lighted area. Some lights operate in a lighted area but do not operate in TOTAL darkness.

You should store the batteries for the SDU-5/E light in a cold area (refrigerator) to prolong their service life and dependability.

To avoid causing possible night blindness to the crewman by accidental activation, install the SDU-5/E light in the SV-2 survival vest with the dome down and a protective cap installed over the switch.

INDIVIDUAL AIRCREWMAN'S SURVIVAL KIT (SRU-31/P)

The complete SRU-31/P kit consists of two parts; the first packet contains medical items that

an aircrewman might need in an emergency situation. The local medical department has responsibility for the medical items that are contained in packet number one.

Packet number two contains general survival items. They are also intended to be used only in an emergency situation.

Packet one and packet two are contained in a carrying bag. Each packet can be replaced individually. Each item within a packet is packed in a transparent bag, which is hermetically sealed and retained in place by means of hook-and-pile tape. Additional adhesive-backed discs of hook-and-pile tape are contained in the spare pocket of each container.

MEDICAL PACKET

The following items are contained in the medical packet of the SRU-31/P kit:

Soap. Nonperfumed, intended to avoid detection.

Instruction card. Provides general condensed instructions on use of survival items.

Antidiarrhea tablets. Dosage rates listed on instruction card. Expiration 4 years.

Pain killer (aspirin). Expiration date listed on foil packet. Replace as required. Dosage rate listed on instruction card.

Band-Aids.

Surgical tape. Ensure the package is intact and its sterile seal is not damaged.

Eye ointment. Expiration date of 5 years.

Water purification tablets. Manufacturer's date and applicable instructions listed on bottle.

Bandage (elastic). Ensure package is intact and sterile seal is not damaged.

Insect repellent.

GENERAL PACKET

The following items are contained in the General Packet of the SRU-3/P kit:

Metal matches. These may cause spontaneous ignition through oxidation. The match should remain in its original sealed container (foil wrapped) until ready for use. All metal matches in polyethylene and open packets must be removed from service and discarded in a fireproof container.

Mirror. This is the signaling mirror described at the beginning of this chapter.

Water bag. One-quart capacity. Belt loops provided for convenient carrying.

Signal panel. Silver/orange paulin, imprinted with the ground-to-air emergency code. It also may be used as a blanket for protection against unfavorable weather.

Mosquito headnet and mittens. Provided for protection against insect bites.

Chiclets. Multi-flavored gum, designed to relieve tension.

Multiflavored candy. Service shelf life is indefinite.

Flash guards. The flash guards are used in conjunction with the SDU-5/E light as a signal device during rescue operations. The flash guards are blue or red in color.

The packet also contains surgical tape, a water receptacle, wrist compass, razor knife, tweezers, and pins.

INSPECTION

You should inspect all the items in the SRU-31/P survival kit during periodic equipment inspections and replace them as necessary.

RATIONS

The rations carried by aircrew personnel are not intended for subsistence but as a source of quick energy when no other food is available.

The food packet contains two packets of candy and gum, twine, and an instruction sheet.



239.402

Figure 5-5.—Rations.

When you inspect any item that contains these rations, you should remove and replace any food packet that is older than 6 1/2 years (fig. 5-5).

CANNED DRINKING WATER

Canned drinking water (fig. 5-6) is intended for use in emergencies when no other clean water

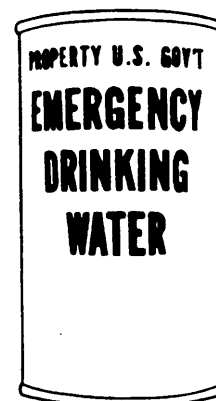

239.403

Figure 5-6.—Canned drinking water.

is available. One can of water supports a survivor for about 1 day.

A can of drinking water contains 10 ounces of pure drinking water and may be carried in this ready-to-use state.

The canned drinking water should be inspected upon issue and every 90 days thereafter, or at intervals to coincide with the inspection schedule of the kit or assembly in which the can is stored. Inspection will consist of the slap test and the shelf life and service life check.

The slap test consists of slapping the can of water against the palm of your hand and listening for a sharp metallic click. This noise is caused by the absence of air to cushion the impact of the water against the can. If this distinct noise is not heard, then air has leaked into the can and it should be replaced.

The shelf life and the service life of canned water are both indefinite as long as the cans pass the slap test and there are no signs of exterior deterioration.

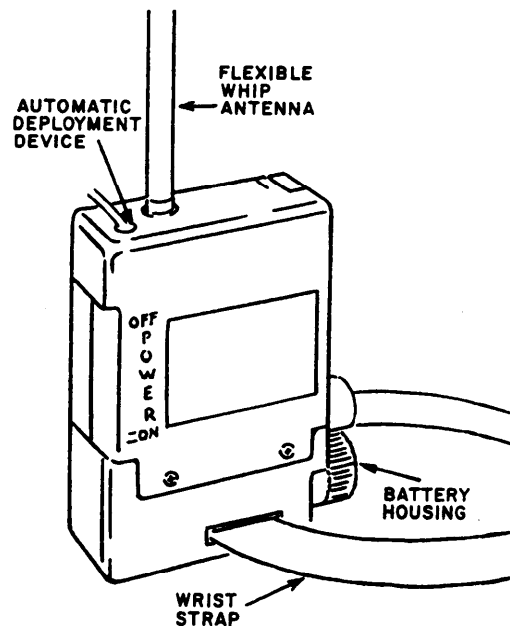

239.437

Figure 5-7.—AN/PRC-63 radio set.

SURVIVAL RADIOS AND BEACONS

Today's rescue procedures are based upon early detection and fast recovery of the surviving aircrewman. Once an aircrewman has been placed into a survival position, it is essential that he be located as soon as possible. The one item that can accomplish this is the survival radio.

Navy aircrewmen carry, as part of their personal survival equipment, a two-way communication radio. This radio is either the AN/PRC-63 or the AN/PRC-90. You must check each aircrewman's radio when you perform the 90-day calendar inspection on his survival equipment.

This chapter describes the operation and inspection of these radios. It also covers the AN/URT-33A and the AN/PRT-5 radio transmitters.

AN/PRC-63 RADIO SET

The AN/PRC-63 radio set is a compact, rugged, lightweight, battery-powered, micro-electronic transceiver. (See figure 5-7.) The radio set has three basic modes of operation:

1. beacon tone transmission (activated either manually or by means of an automatic deployment device);
2. voice transmission; and
3. voice reception.

Simplicity of operation has been the keynote in the design of the AN/PRC-63 radio set. A slide switch turns the radio set on (in beacon mode) or off, and a three-position toggle switch changes from beacon transmit to either voice transmit or voice receive. A volume control, located in the upper corner of the radio set, controls the level of sound output of the beacon confidence tone (used to verify that the beacon signal is getting out) and the receiver. No other controls have been provided or are required. All these controls can be operated with either hand (bare or gloved). If the user loses consciousness and releases the radio set (once turned on), it automatically returns to the beacon mode of operation.

General Principles of Operation

The AN/PRC-63 radio set provides two-way voice communication with a searching aircraft that is equipped with compatible transmitting and receiving equipment within a range of 25 miles and an altitude of 10,000 feet. A search aircraft flying at 10,000 feet and equipped with compatible direction-finding equipment can locate an AN/PRC-63 radio set transmitting in the beacon mode at a distance of approximately 70 miles

(line of sight) between the search aircraft and the radio set.

The AN/PRC-63 radio set can be worn as part of the aircrewman's flight clothing or life jacket; it is secured to the garment by a strap attached to the slots in the battery housing. The automatic deployment device supplied with the radio set, when suitably connected to the parachute harness of the aircrewman by the user, will allow automatic transmission of the beacon tone upon parachute deployment. The radio can also be packed in a seat pack and, with the same deployment device suitably connected, can be automatically placed in beacon tone transmission mode upon ejection from the aircraft. The lanyard attached to the deployment device has been designed to withstand a pull force of 20 pounds without breaking.

The downed aircrewman may remove the radio set from his flight clothing, life jacket, or survival kit and change its mode of operation to either voice transmit or voice receive by pressing the appropriate end of the rocking toggle actuator. In the event that he becomes injured, disabled, or otherwise incapable of selecting the desired mode of operation, the radio set will continue to transmit MCW beacon signals until the battery power is exhausted.

Function and Use of Operating Controls

The function and use of the operating controls are described in table 5-1.

NOTE: When POWER ON/OFF actuator is in OFF position or in ON position with the deployment device installed, all other operating controls are disabled.

The radio set can be held in either hand and operated by the thumb or fingers, respectively. In the normal operating position, the speaker/mike faces the operator.

NOTE: During operation, the radio set must be held in the upright position (antenna vertical), or loss of transmission or reception will result. For best results, hold the radio set approximately 1 to 2 inches from the mouth when speaking, or ear when listening.

In the receive mode the sound is controlled by the volume control knob, which is located in the upper corner of the radio set (opposite the flexible whip antenna) and marked VOLUME MAX. Full clockwise rotation gives maximum volume; full counter-clockwise rotation gives minimum volume. The sound of the beacon monitoring tone is also controlled by this knob.

NOTE: Neither the beacon nor voice-transmitter output is affected by the position of the volume control knob.

Table 5-1.—Operating Controls and Functions

Control	Function
POWER OFF	Radio set is in storage condition.
POWER ON	Radio set is in beacon mode of operation.
POWER ON Deployment device installed	Radio set is in standby condition ready for automatic activation.
POWER ON RECEIVE VOICE PRESS AND HOLD	Radio set is in receive mode.
POWER ON TRANSMIT VOICE PRESS AND HOLD	Radio set is in transmit mode.

Inspections

There are three inspections/test intervals prescribed for this type of radio. (They are also prescribed for the AN/PRC-90.) The first daily/preflight is performed at the squadron level by the aircrewman. It is to be performed daily or prior to each flight. It consists of a basic operational check using an AN/PRM-32 radio tester or with the aid of a known good radio. Prior to testing the emergency radio, you should call flight operations to inform them that you are going to test a radio.

Every 90 days the radio must be inspected by the PR at the organizational level. It is best to make this inspection in conjunction with the inspection performed on the aircrewmen's personal survival equipment.

The last of the three inspections is performed at the intermediate level (AIMD). This inspection is performed every 180 days by personnel in the avionics rating.

The testing procedures for all three inspections are outlined in NAVAIR 16-30PRC 90-2 for the AN/PRC-90 radio and in NAVAIR 16-30PRC 63-1 for the AN/PRC-63.

Battery Replacement

The Mallory battery will require frequent inspections to ensure that it hasn't lost any of its operating life. When operating in a high-temperature area, the inspection should be conducted at least every 30 days. The service and shelf life of the battery expires 36 months from the date of manufacture. When the battery fails to produce the power for the radio to operate at maximum operating range, you must replace it. Any battery that shows evidence of a swelling, chipped, or cracked surface, or moisture must be condemned and a new battery installed.

AN/PRC-90 RADIO SET

The AN/PRC-90 (fig. 5-8) radio set is a dual channel, battery-powered, personal emergency rescue device used principally for two-day voice or MCW (modulated continuous wave, which is used to send Morse code signals) communications between a downed aircrewman and a rescue aircraft. The radio transmits either voice, tone (MCW), or swept-frequency homing beacon

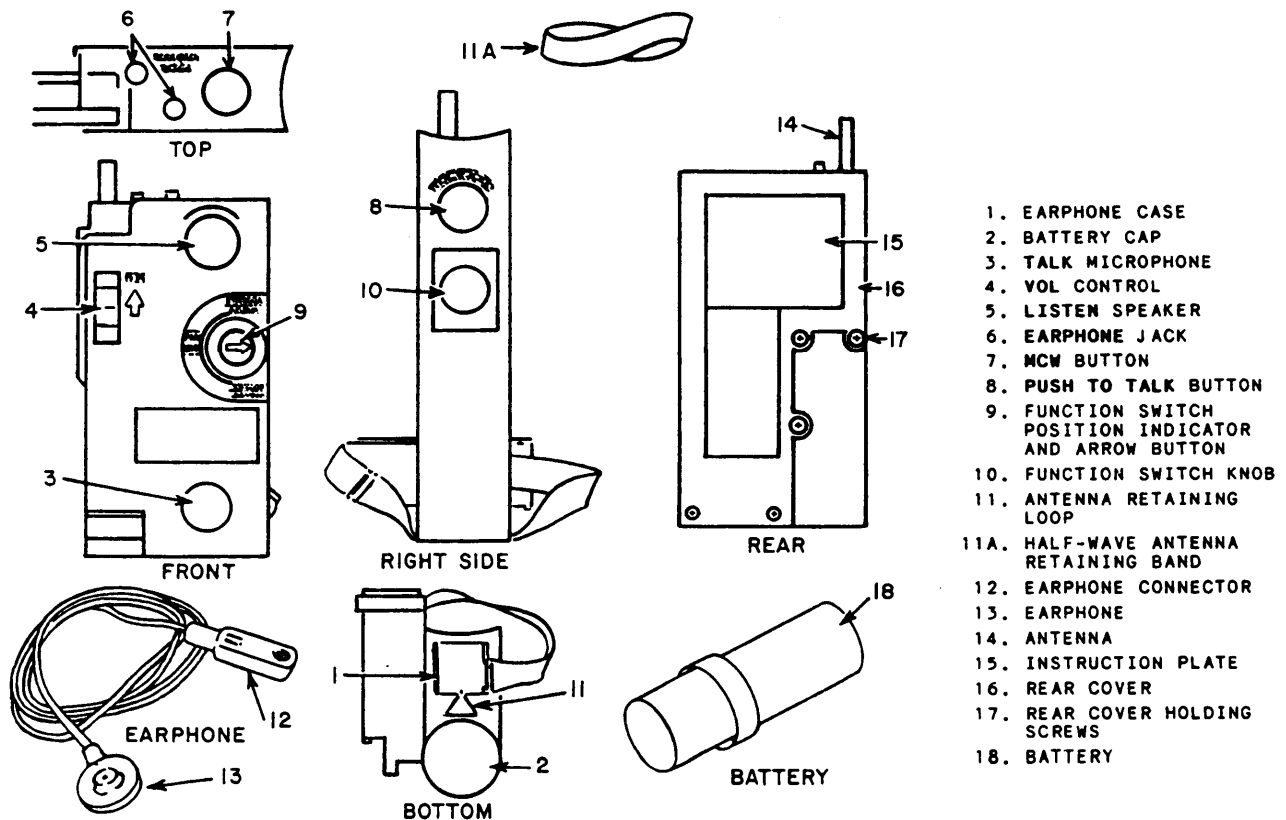

Figure 5-8.—AN/PRC-90 controls and indicators.

signals to guide rescue aircraft to the downed aircrewman. Although the PRC-90 is a line-of-sight communications device, it has a voice range under ideal conditions of 60 nautical miles to aircraft operating at 10,000 feet. The automatic direction finder has a range of 50 nautical miles and atone (code signal) range of 80 nautical miles to aircraft operating at an altitude of 10,000 feet.

Batteries

The batteries are tested by using Test Set TS 2530/UR. Batteries are considered to have a maximum shelf life of 36 months from the date of manufacture. This shelf life is based upon a

storage temperature of 70 °F. If the temperature increases, their storage life is shortened. For example, if the temperature reaches 130 °F, the storage life can be reduced to as short as 1 month. When you are in an activity that uses this battery, you should refer to NAVAIR 16-30PRC 90 for the most current shelf life information.

Operating Procedure

Refer to table 5-2 for the functions of each control on the PRC-90. The set is operated as follows:

1. Free the antenna from its stowed position by pulling its end from the retaining ring or band

Table 5-2.—Operating Controls and Indicators

Control or Indicator	Control Position	Function
Function switch	OFF VOICE/MCW 243.0	Completely removes power from radio set. Turns on the guard channel receiver to the emergency frequency of 243.0 MHz. Also enables voice and MCW guard channel transmission which are keyed by the PUSH TO TALK or MCW buttons.
	BCN 243.0	Turns on 243.0 MHz guard channel transmitter, and transmits a beacon tone. Swept audio tone is continuously transmitted for rescue aircraft to home on.
	VOICE 282.8 NOTE The button, (9, figure 5-8) must be depressed to place function switch in the VOICE 282.8 position.	Turns on alternate channel to receive on 282.8 MHz. Also enables voice transmission on auxiliary channel when PUSH TO TALK button is depressed.
PUSH TO TALK button	Depressed	Turns receiver off and turns transmitter on when function switch is in either VOICE/MCW 243.0 or VOICE 282.8 position. Best voice transmissions are obtained when spoken directly into the talk microphone.
	Released	Turns off transmitter and turns on receiver; received signal is heard with ear close to LISTEN speaker or earphone.

Table 5-2.—Operating Controls and Indicators—Continued

Control or Indicator	Control Position	Function
MCW button	Depressed	<p>This button is a telegraph key; it enables the operator to transmit code when the normal transmitting level of his voice may reveal his position. MCW is only obtainable when the function switch is in the VOICE/MCW 243.0 position.</p> <p>Causes radio set to transmit a continuous tone, receiver off.</p>
VOL control	Released	<p>Turns transmitter off, receiver on.</p> <p>This controls the volume of the sound from the LISTEN speaker or earphone. It controls received signals, not sidetone.</p>
LISTEN speaker	Fully Up, MAX	<p>Loudest sound</p>
TALK microphone	Fully down	<p>Quietest sound, but radio set is not turned off.</p> <p style="text-align: center;">NOTE</p> <p>Volume control does not affect transmitted power output.</p>
Earphone jack	Earphone connected	<p>Sound of received signal is heard by placing ear close to LISTEN speaker. Sound of MCW or beacon transmitter may also be heard. The LISTEN speaker is shut off when the earphone is connected.</p> <p>Picks up the voice being transmitted when PUSH TO TALK button is depressed and function switch is set to either VOICE/MCW 243.0 or VOICE 282.8.</p> <p>Causes sound to be heard in earphone. A magnet in the earphone connector (12, figure 5-8) shuts off the LISTEN speaker.</p>
Battery cap	<p style="text-align: center;">NOTE</p> <p>Connector may be joined to jack in either of two polarities.</p> <p>Earphone disconnected</p>	<p>Sound is heard through LISTEN speaker.</p> <p>Holds battery in place.</p>

as appropriate. The antenna snaps into an upright position. Fully extend all five telescopic sections of the half-wave antenna by grasping it by its tip and pulling outward.

2. Set the function switch to the mode of operation that you want. The function switch is set by rotating the thumb knob on the right-hand side so that the arrow points to the mode selected. The function switch is detented and clicks into each position. Rotate the knob down one click (from OFF) for VOICE/MCW 243.0 operation, or two clicks for BCN 243.0 operation. For VOICE 282.8 operation (secondary channel), push the button with the arrow and rotate the function switch knob up one click.

3. For voice operation, hold the radio set and adjust the VOL control. To transmit, push down the PRESS TO TALK button and speak directly into the TALK microphone.

4. If guard channel steady-tone transmission or Morse code operation is desired, set the function switch to VOICE/MCW 243.0. Depress the MCW button to transmit the tone. Listen for the sidetone in the LISTEN speaker or earphone while the MCW button is depressed. This sidetone indicates proper transmitter operation.

5. For guard channel beacon operation, set the function switch to BCN 243.0. The transmitter

continuously sends the swept-tone beacon signal at this setting. Listen for the sidetone as an indication of proper operation. In the beacon mode, the sidetone is a chirping sound.

NOTE: Since the transmitter is keyed automatically in the beacon mode, and since continuous transmission may be needed for a prolonged period of time, the AN/PRC-90 may be placed upright on a flat surface. It will then transmit automatically.

AN/URT-33A BEACON SET RADIO

The Beacon Set Radio, AN/URT-33A (figs. 5-9 and 5-10), is an emergency radio beacon transmitter that, when properly actuated, transmits a tone-modulated radio frequency signal on the emergency guard frequency of 243.0 MHz.

Although the AN/URT-33A was designed to be placed into a parachute pack, the Navy normally places the beacon radio into the seat pan (RSSK) or life rafts. Instructions for properly rigging the AN/URT-33A can be found in NAVAIR 13-1-6.1.

The AN/URT-33 radio has two types of antennae. One type is the flexible wire antenna. This antenna is used during parachute descent

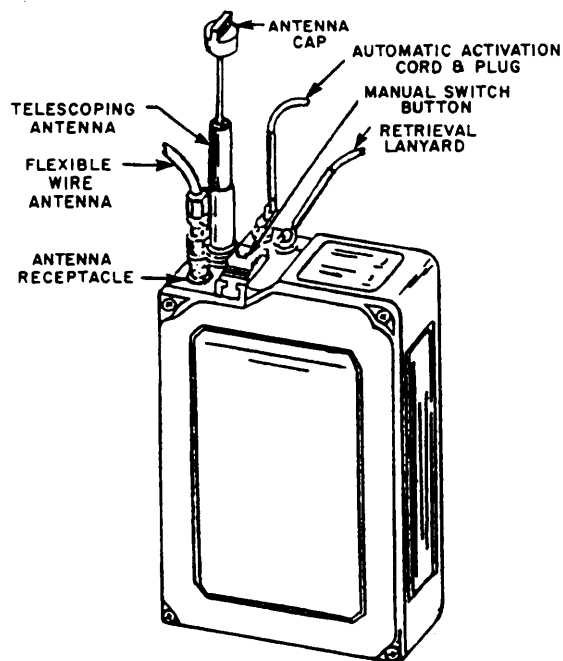

239.439

Figure 5-9.—Beacon set, radio, AN/URT-33A (front view).

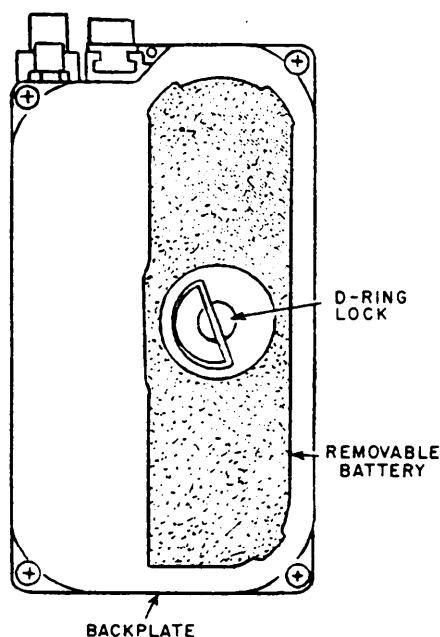

239.440

Figure 5-10.—Beacon set, radio, AN/URT-33A (rear view).

since the radio is activated when the aircrewman leaves the aircraft.

The flexible wire antenna serves as the principal antenna during descent. Upon landing, the flexible antenna is removed by the aircrewman, and a telescopic antenna that is built into the radio is used.

The AN/URT-33A radio is battery-operated. The battery is a mercury type with a storage life of 24 months, provided that the storage temperature is 70°F. At a storage temperature of 100°F, the storage life is only 12 months. For survival equipment applications, such as rigid seat survival

kits and life rafts, the service life of the battery assembly is 2 years from the date of manufacture, 225 days from the date placed into service, or 231 days for the SKU-2/A or RSSK-7 seat survival kit. Ensure that the battery service life does not expire prior to the next scheduled inspection of the assembly in which the radio beacon set is installed.

AN/PRT-5 TRANSMITTING SET

Transmitting Set, Radio AN/PRT-5 (fig. 5-11) is a battery-operated, emergency beacon

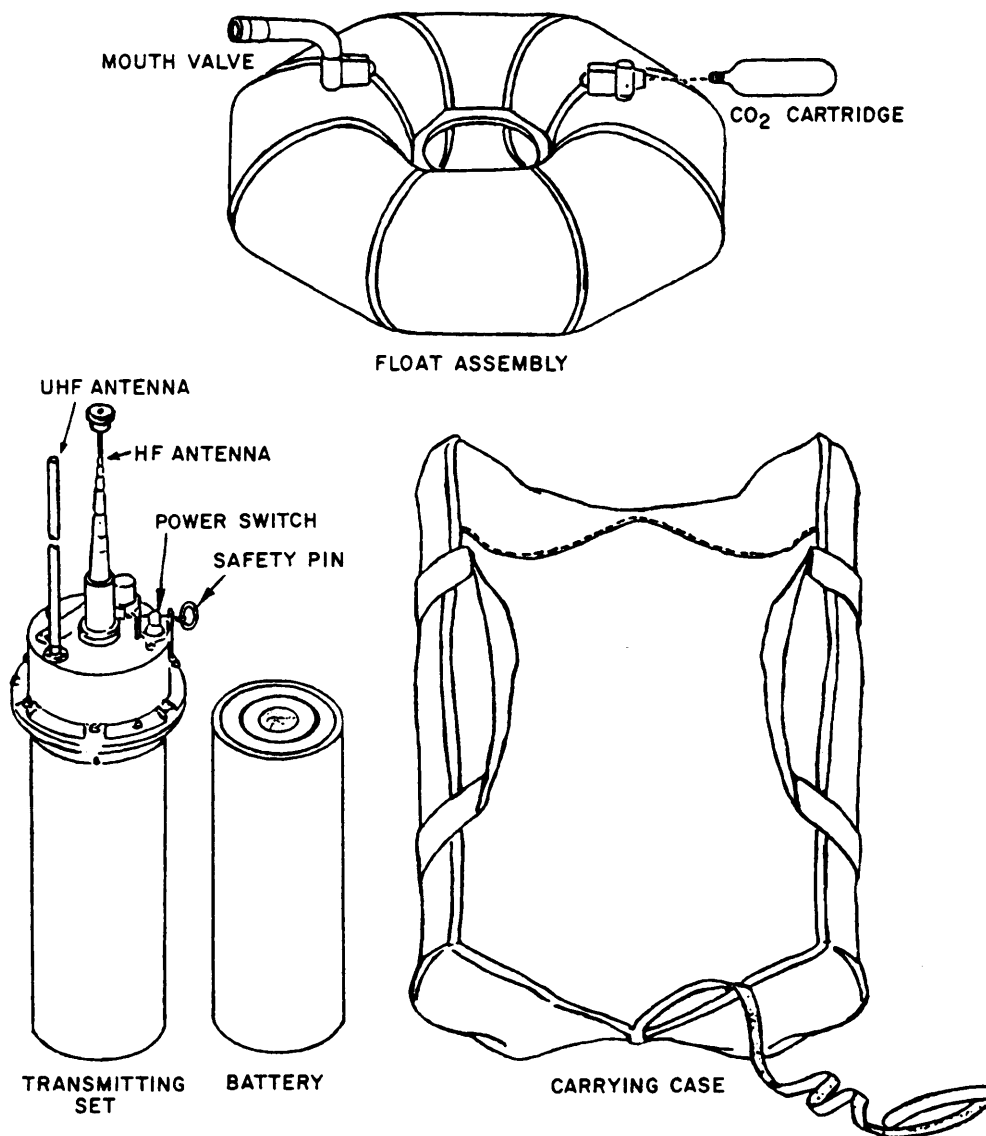

Figure 5-11.—Transmitting set, radio, AN/PRT-5, identification of components.

239.441

transmitter that, when properly activated, transmits a tone-modulated radio frequency signal on the emergency guard frequencies of 8.364 MHz and 243.0 MHz simultaneously. The transmitting set includes an inflatable float assembly that keeps the transmitting set afloat at sea, and provides a support platform on land. The entire set is packed in a carrying case for stowing in a life raft.

The transmitting set is intended for signaling the location of downed aircraft or airmen. Because it provides signals in both the high frequency (HF) and ultra high frequency (UHF) portions of the spectrum, it can be detected by search aircraft, surface vessels, and coastal-based stations at considerable distances.

The battery pack is designed to provide 72 hours of continuous operation at 25°C (77°F) with at least 250 milliwatts of output from each transmitter at the end of this period. The transmitting set will continue to transmit until the battery pack is completely discharged.

Modulation of the transmitter is by internal means only. No provision has been made for voice or code communications, or for receiving signals from search craft.

To prepare the radio for use is a simple procedure.

1. Pull the free end of the UHF antenna through the grommet in the float assembly to allow the antenna to stand vertically.

2. Unscrew the top section cap of the telescopic HF antenna, and pull the antenna out to its full length. When fully raised the antenna sections are alternate black and gray with the top section gray. The antenna, when fully extended, is approximately 9 feet high. (See figure 5-12.)

3. Pull out the switch safety pin (fig. 5-11).

4. Turn the POWER toggle switch to ON (fig. 5-11).

5. Place the entire assembly in the water and tow it behind the life raft.

6. When operating on land, be sure the transmitting set is placed on level ground so that the antennas are vertical. Do not stand close to the transmitting set because this can cause changes in the radiation pattern of the transmitted signals.

7. If desired, the safety pin can be replaced to prevent the transmitting set from being turned off accidentally.

HELICOPTER RESCUE DEVICES

Every Aircrew Survival Equipmentman should be familiar with the equipment used in rescue

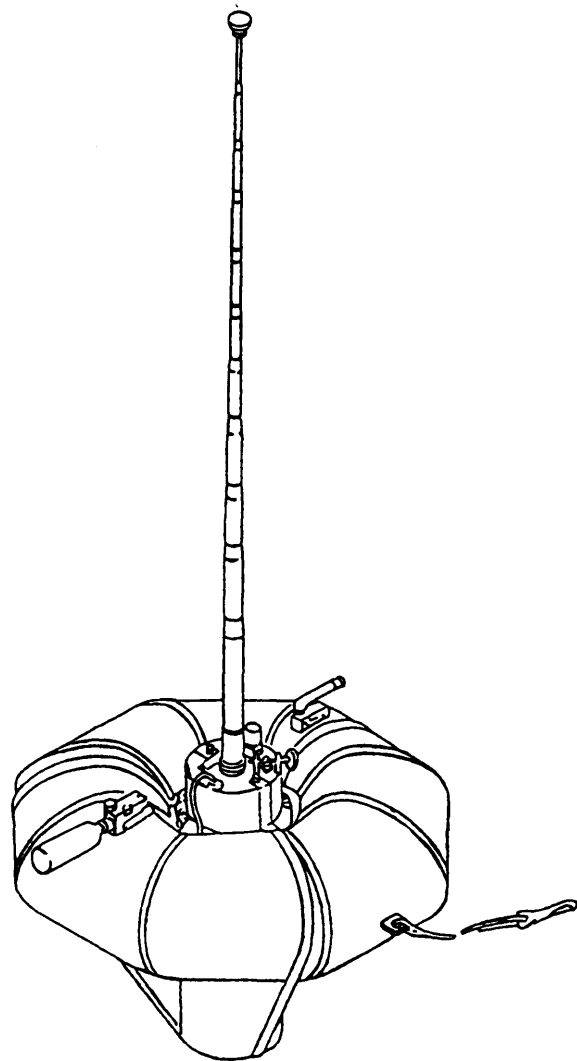

239.442

Figure 5-12.—Transmitting set, radio, AN/PRT-5 with flotation collar.

from the sea or land by helicopters. (Refer to *Navy Search and Rescue Manual*, NWP 19-1, for procedures and techniques involving at-sea aircrew rescues.) The helicopter's ability to land and takeoff in a small area and to hover over a spot lends itself very effectively to rescue work.

There are three methods by which a helicopter may make a rescue. The first is by hovering, the second by landing, and the third by making a low, slow pass with the rescue device hanging near ground level. The latter is used mainly in hostile areas when the helicopter pilot does not wish to present the aircraft or the survivor as a stationary target for enemy gunners. By far, the most common helicopter pickup is made by hovering.

NOTE: A static charge of electricity is built up in the helicopter and must be dissipated by grounding. Do NOT touch the rescue device until after it has contacted the ground or water to permit the discharge of static electricity and prevent electrical shock.

Research, development, test, and evaluation of air rescue devices has been continuous since the helicopter became the primary rescue vehicle. The various types of rescue devices, their functions, and associated maintenance procedures are discussed in the sections that follow.

All helicopter rescue devices must be scheduled into periodic maintenance under the direction and control of the maintenance/material control officer to which the equipment is assigned. Maintenance must be thorough at all times. No instance of careless treatment or willful neglect of aircrew personal protective equipment will be condoned. The vital function of the equipment must be uppermost in the minds of all personnel concerned.

Individual parafofts normally store and maintain all helicopter rescue devices, and checkout is on an individual basis. Because of the lack of individual identification of the rescue devices, it is impossible to match the Aviation Crew Systems History Card to the rescue device. All rescue devices should be locally serialized by individual parafofts to ensure positive control of inspection cycles performed on helicopter rescue devices.

SURVIVOR'S SLING

The survivor's sling is a buoyant device consisting of a kapok filling encased in a bright yellow waterproof cover to make it highly visible during rescue operations. Webbing, reeved through the cover with both ends terminating in two V-rings, is used to attach the sling to the helicopter rescue hook. Two retainer straps, one long with a quick-ejector snap and one short with a V-ring, are fastened to the webbing of the sling and are enclosed in slide fastener-secured envelopes. Refer to figures 5-13 and 5-14.

The survivor's sling (also known as the "horse collar" and rescue sling) is used to assist personnel performing rescue work from a helicopter over water or land. The survivor's sling is lowered on a hoist cable from a helicopter to the rescue swimmer and survivor. The sling is designed to accommodate one survivor at a time.

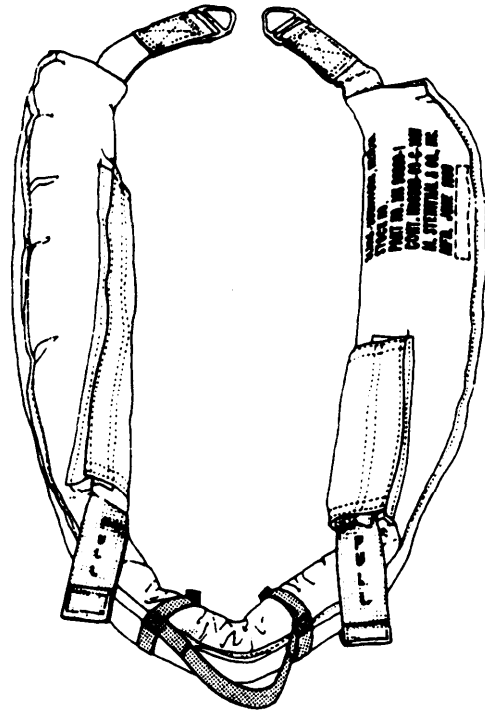

239.404A

Figure 5-13.—Survivor's sling.

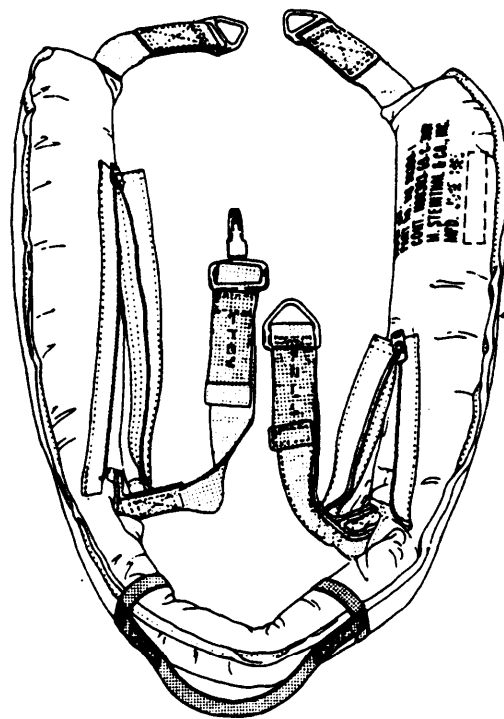

239.404B

Figure 5-14.—Survivor's sling retainer straps pulled out.

Maintenance

The aircrewman's responsibility for maintenance of the survivor's sling is limited to a freshwater wash. Repairs or other actions are performed by organizational-level maintenance or above.

All survivor's slings are subject to a calendar inspection upon issue and at intervals not to exceed 225 days. All survivor's slings are subject to a preflight inspection also. This action is performed by the aircrewman before each flight and at least every 14 days. This inspection consists of a visual inspection outlined in the calendar inspection procedures.

Calendar Inspections

The calendar inspection consists of a visual inspection and a proof load test.

To perform the visual inspection, proceed as follows:

1. Inspect all fabric for cuts, deterioration, and abrasion.
2. Inspect seams for proper adhesion and stitching.
3. Inspect the retainer straps for security of attachment and wear.
4. Inspect all hardware for security of attachment, corrosion, damage, wear, and, if applicable, ease of operation.
5. Inspect all markings. If the markings are faded or incorrect, they must be corrected by using black washproof ink.

The proof load test is performed on the survivor's sling during the calendar inspection and after each flight in which saltwater immersion has occurred. To perform a proof load test, proceed as follows:

1. Allow the sling to dry completely.
2. Inspect for damage to webbing of survivor's sling. Damage other than frayed or separated stitches is cause for replacement.
3. Place the survivor's sling in a webbing testing machine.

NOTE: If a webbing testing machine is not available, refer to NAVAIR 13-1-6.5 for a suitable alternate testing method.

4. Apply a load of 500 pounds at a rate of 1 inch per minute.
5. Again, inspect for any damage to the webbing of the survivor's sling. Damage other than frayed or separated stitches is cause for replacement.

6. Remove the sling from the webbing testing machine.

The survivor's sling must be cleaned after every immersion in salt water. To clean the survivor's sling, proceed as follows:

1. Clean the sling and its cover with a mild soap and water solution. Rinse well with fresh water.
2. Dry the sling and its cover with a clean, dry, lint-free cloth.

RESCUE SEAT

The rescue seat is a buoyant aluminum device consisting of a hollow flotation chamber and a three-pronged seat, with prongs 120 degrees apart (fig. 5-15). Lead is inserted in the base of the

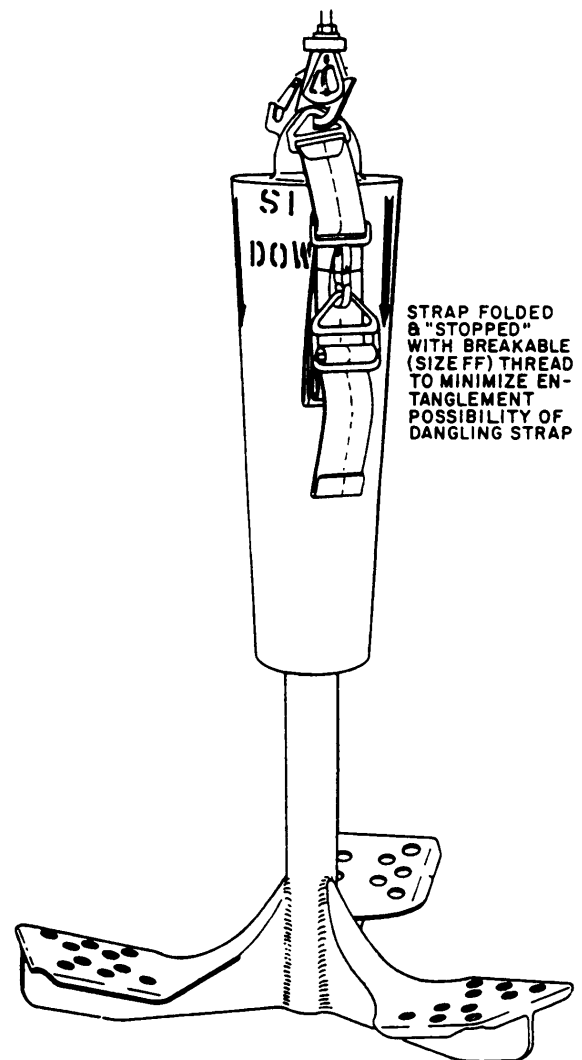

239.405

Figure 5-15.—Helicopter rescue seat.

assembly to minimize roll and to provide the proper degree of submergence of the seat in the water. A safety strap is provided to assist the survivor to remain in the seat during hoisting to the helicopter. The flotation chamber and hoist bracket of the seat are bright orange. The lower seat assembly is yellow for high visibility.

The helicopter rescue seat is intended for use in retrieving survivors and assisting the rescue swimmer in performing rescue operations when it is difficult to make a helicopter landing over land or water.

When conducting a rescue, the helicopter rescue seat is lowered on a hoist cable from a helicopter to the rescue swimmer and survivor. The rescue seat is designed to accommodate one person at a time.

Maintenance

The aircrewman's responsibility for maintenance of the rescue seat is limited to freshwater wash after usage. Repairs or other maintenance actions required are performed by organizational-level maintenance or above.

Inspection

All rescue seats are given a calendar inspection upon issue and at intervals of 225 days. The calendar inspection is a visual inspection. To visually inspect the condition of the rescue seat, proceed as follows:

1. Inspect all components for security of attachment, corrosion, damage, wear, discoloration, and ease of operation.
2. Check for sharp edges or projections.
3. Check material for imperfections or damage.
4. Check safety strap for fraying or tears.
5. Compare markings on seat to markings listed in applicable table in NAVAIR 13-1-6.5.

If the markings are faded, restore them with black washproof ink. If marking is incorrect, paint it out and enter the correct marking as close to the proper location as possible, using black washproof ink.

Cleaning

The rescue seat must be cleaned after every immersion in salt water. Clean it as follows:

1. Wash the rescue seat with a mild soap and water solution. Rinse well with fresh water.
2. Dry the rescue seat with a clean, dry, lint-free cloth.
3. Return the seat to service.

FOREST PENETRATOR AND FLOTATION COLLAR

The forest penetrator is bright yellow for high visibility, and is a compact device weighing about 21 1/2 pounds. The forest penetrator is 34 inches long and 8 1/8 inches in diameter with the three seats retracted, and 26 inches in diameter with the seats extended. Each seat is 4 3/4 inches wide, 11 1/2 inches long, and is spring-loaded in the retracted position (flush against the shaft of the penetrator). A spring-loaded retaining latch is provided under each seat to secure the seat in the extended position. To release the seat, push down on the seat and pull down on the latch. The seat then snaps back into the retracted position. Three webbing safety straps are provided to hold the survivors in place. Each strap extends 4 feet 9 1/4 inches, with an adjustable quick-ejector hook attached to the upper section of the penetrator. The straps terminate with a yellow fabric, marked TIGHTEN. Yellow webbing tabs (with hook tape) marked PULL OUT are sewn to the safety straps for attachment to fabric cover stowage openings. The yellow fabric cover has a 17-inch slide fastener and three stowage openings (with pile tape for securing safety straps). (See figure 5-16.)

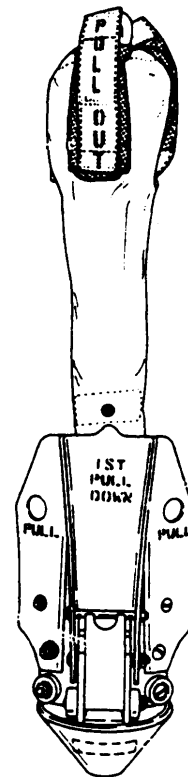
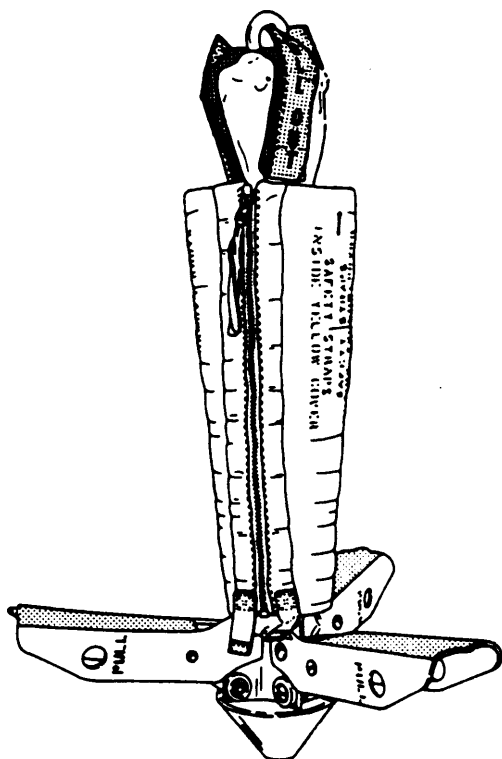

Figure 5-16.—Forest penetrator.

239.406A



239.406B

Figure 5-17.—Flotation collar installed on forest penetrator.

The flotation collar is made of bright orange foam rubber for high visibility and weighs about 1 1/2 pounds. (See figure 5-17.) It is 2 1/4 inches long, with a 7 3/4-inch diameter at the top and a 4-inch diameter at the bottom. When the flotation collar is installed on the forest penetrator, the retracted diameter at the penetrator is 9 inches.

The forest penetrator and flotation collar are intended to assist the rescue swimmer to perform rescue operations in the water or to rescue survivors on land.

The flotation collar is a device that, when fastened around the forest penetrator, allows flotation of the complete assembly during air-sea rescue operations.

During land rescue operations, the forest penetrator is lowered to the survivor with the seats retracted. For sea operations the forest penetrator is lowered to the rescue swimmer and survivor with the flotation collar installed, safety straps hanging free, and the seats retracted. In this configuration, the penetrator will float its top about 6 inches above the surface of the water.

The forest penetrator is designed to accommodate one, two, or three survivors at the same time.

Maintenance

The aircrewman's responsibility for maintenance of the forest penetrator is limited to washing with fresh water. Repairs or other actions are performed by organizational-level maintenance or above.

Inspection

All forest penetrators receive a calendar inspection upon issue and at intervals not to exceed 225 days. The calendar inspection consists of visually inspecting both the forest penetrator and flotation collar.

When inspecting the condition of the forest penetrator and flotation collar, examine the following:

1. All fabrics for cuts, tears, deterioration, and abrasion.
2. Seams for proper stitching.
3. Straps for security of attachment and wear.
4. Any other parts for wear, damage, and security of attachment.
5. All hardware for security of attachment, corrosion, damage, wear, and, if applicable, ease of operation.
6. The cover for strains, dirt, and general condition.
7. The slide fastener for damage, corrosion, and ease of operation.
8. Compare markings on the forest penetrator and flotation collar to markings listed on the applicable tables in NAVAIR 13-1-6.5. Restore any faded markings, and correct markings, if necessary, with indelible ink.

Cleaning

The forest penetrator and flotation collar must be cleaned after every immersion in salt water as follows:

1. Wash the penetrator and collar with a mild soap and water solution. Rinse well with fresh water.
2. Wipe the penetrator and collar with clean, lint-free cloth and allow to dry.
3. If necessary, apply silicone lubricant to slide fasteners on the cover of the penetrator to ensure ease of operation.

4. Apply a lubricating oil to all pivot points of the penetrator. Wipe off excessive lubricating oil.

5. Return both assemblies to service.

RESCUE NET

The rescue net looks like a conically shaped birdcage with an opening on one side. The net weighs approximately 20 pounds and is bright yellow for high visibility. To stabilize the net during use, a sea anchor is provided. A 10-foot sea

anchor retaining line with two single snap hooks is also provided. One halyard snap hook permits complete removal of the sea anchor from the net, while the other snap hook permits shortening of the sea anchor to 5 feet to be used in moderate seas. During high seas, the 10-foot retainer line is used. The rescue net has a snap lock lower frame and three upper support ribs with sliding sleeves that form a rigid cage when the net is fully extended. Foam plastic floats are provided on the rigid upper frame of the net. (See figure 5-18.)

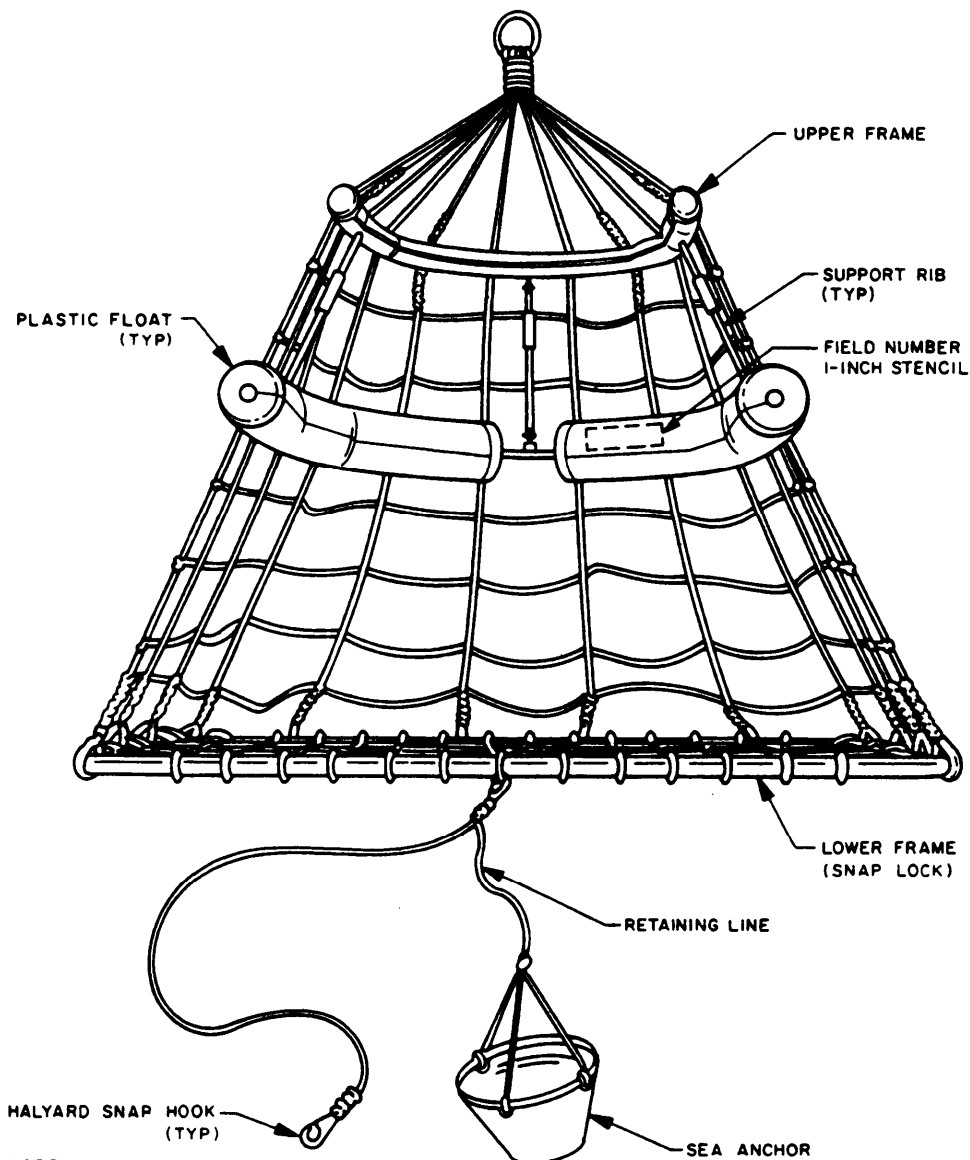

NOTE:

CARGO DOOR AND SEA ANCHOR ARE ALSO SUPPLIED AS OPTIONAL PIECES OF EQUIPMENT WITH THE RESCUE NET.

Figure 5-18.—Rescue net, parts nomenclature.

239.407

The rescue net is used to assist the rescue swimmer performing rescue work from a helicopter over water or land. The rescue net may also be used to ferry or pick up cargo.

WARNING

THE SEA ANCHOR MUST NOT BE USED WHEN HOISTING PERSONNEL OUT OF THE WATER.

Maintenance

The aircrewman's responsibility for maintenance of the rescue net is limited to a freshwater wash after use. Repairs or other actions required are performed by organizational-level maintenance or above.

Inspection

All rescue nets are given a calendar inspection upon issue and at intervals of 225 days. The calendar inspection for the rescue net consists of the following visual inspection:

1. Erect the net by unfolding its lower frame assembly and forcing the assembly down. The frame will snap open.
2. Suspend the open section of the net and slide sleeves or the upper support ribs between the swivel joints. The sleeves rest on the support rib stops.
3. Inspect all hardware for security of attachment, corrosion, damage, wear, and ease of operation.

Cleaning

To clean the rescue net, proceed as follows:

1. Wash the rescue net with a mild soap and water solution. Rinse well with fresh water.
2. Allow the net to air dry.

RESCUE HARNESS

The rescue harness consists of nylon webbing shoulder straps, riser straps, back strap, an adjustable chest strap, and a lifting strap (fig. 5-19). The end of the lifting strap, equipped with a gated D-ring, adapter assembly, release assembly, and parachute harness triangle link are stowed in a pouch on the front of the harness.

A handle on the pouch allows for ease of accessibility of the gated D-ring during rescue operations. Right and left pocket assemblies are located at each junction of the riser and lifting strap. The left pocket is designed to hold one Mk 13, Mod 0 marine smoke and illumination signal and the right pocket is designed to hold the other Mk 13, Mod 0 marine smoke and illumination signal and the suspension line cutter. A knife scabbard is attached to the left side of the lifting strap.

The rescue harness is designed specifically to be worn by the rescue swimmer, providing him maximum mobility and a means for performing rescue operations in the water.

Maintenance

The aircrewman's responsibility for maintenance of the harness is limited to freshwater wash after usage. Repairs or other maintenance actions required are performed by intermediate-level maintenance or above unless otherwise specified.

Preflight Inspection

The rescue harness preflight inspection is accomplished prior to each flight, and at intervals not to exceed 14 days. This inspection is made by the aircrewman. To perform a preflight inspection, examine the following:

1. Fabric and webbing for cuts, tears, open seams, and loose or broken stitching
2. Signs of contamination, such as stains and discoloration

Calendar Inspection

The calendar inspection is performed by organizational-level maintenance or above upon issue before placing the rescue harness in service and every 90 days thereafter. To perform the calendar inspection, proceed as follows:

1. Service life check. The service life of the rescue harness is 7 years from the date it was placed in service or 8 1/2 years from the date of fabrication, whichever occurs first. When an assembly reaches its

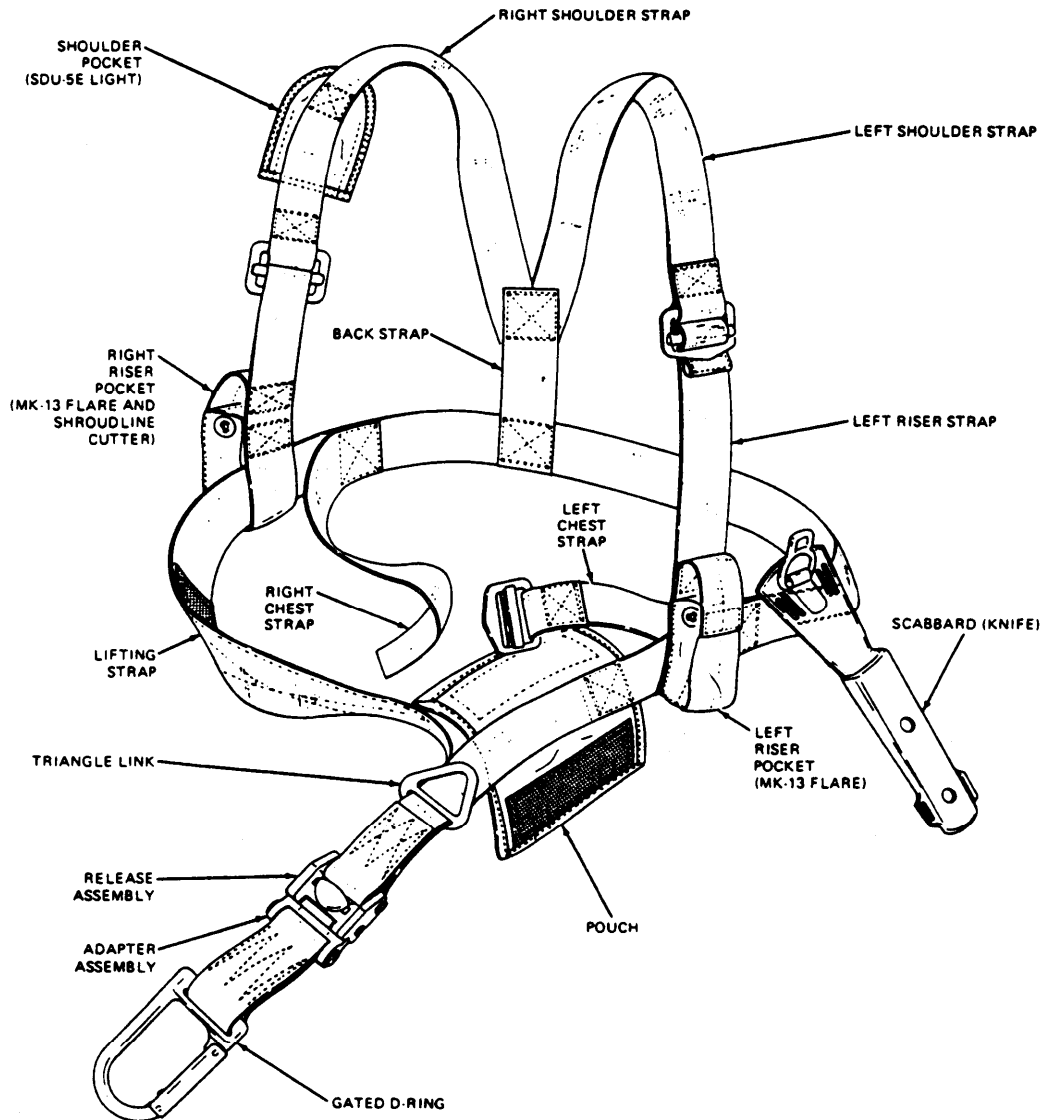

239.408

Figure 5-19.—Rescue harness.

service life limit, it is removed from service and scrapped. To perform a service life check, proceed as follows:

- a. When a rescue harness is placed in service, the start of service date is stenciled on the inside of the chest strap.
- b. When an in-service rescue harness lacks a start service date, service life expires 7 years from date of manufacture.
- c. The date of manufacture is located on the inside of the chest strap.

2. Contamination inspection. To inspect a rescue harness for acid or alkaline contamination, proceed as follows:

CAUTION

ENSURE THE AREA TO BE TESTED IS ISOLATED FROM ANY SOURCE OF CONTAMINATION THAT MAY RESULT IN ERRONEOUS READINGS.

- a. Dampen the suspected area with distilled water.

b. Place a piece of full-range test paper on the dampened area. Compare it to the color standard provided with the paper. The color it changes to indicates the approximate pH reading and which specific short-range test paper to use.

c. Place the short-range test paper on the dampened area. Its color indicates the pH factor of the affected area.

d. If acid contamination is found, the assembly must be considered nonrepairable and scrapped.

e. If alkaline contamination is found, rinse the assembly in cool, fresh water until a safe reading is obtained. All fabric and webbing must then be carefully inspected for any sign of deterioration.

3. Visual inspection. To inspect the rescue harness, examine the following:

a. Harness webbing for cuts, tears, fraying, deterioration, and security of stitching.

b. Front pouch and right and left pockets for cuts, tears, fraying, deterioration, and security of stitching.

c. Gated D-ring and all other hardware for corrosion, distortion, sharp edges, security of attachment, and ease of operation.

d. Hook and pile tape fasteners for condition and proper mating.

Cleaning

Clean the rescue harness as often as necessary to remove perspiration stains, dirt, and other stains that may degrade performance of the assembly. To clean a rescue harness, proceed as follows:

1. Wrap all metal fittings in heavy flannel cloth.

CAUTION

DO NOT SCRUB RESCUE HARNESS.

2. Soak the assembly in cool, fresh water for 2 to 3 hours to loosen any set stains.

3. Drain this water and immerse the harness in a tub of fresh water (not over 120°F). Gently agitate by hand.

4. After 5 to 10 minutes of agitating, repeat step 3.

5. Petroleum and other stubborn stains may be removed by repeated applications of a mild soap and water solution. Each application must be followed by a rinse in cool, fresh water.

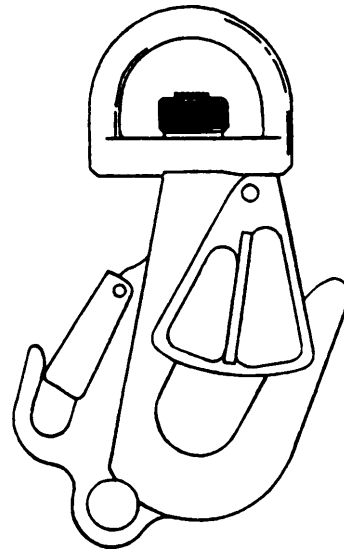

239.409

Figure 5-20.—Rescue hook.

6. Hang the rescue harness on a wooden hanger until dry.

RESCUE HOOK

The rescue hook consists of one large hook, an adjacent small hook, and ring located at the bottom of both-hooks. A bearing assembly is attached to the upper section allowing the hook to rotate freely about its axis. The large hook supports 3,000 pounds and is used to hoist personnel. The smaller hook supports 1,000 pounds and is used to hoist equipment. The ring at the bottom supports 1,500 pounds and is also used to hoist miscellaneous equipment. Both hooks have a spring-loaded latch to prevent inadvertent release of personnel or equipment. (See figure 5-20.)

The rescue hook is attached to the hoist cable and is used to assist rescue personnel in performing rescue operations from a helicopter. The rescue hook can hoist personnel and/or equipment during both sea and land helicopter rescues.

Maintenance

The aircrewman's responsibility is to inform maintenance control if equipment has been immersed in salt water. Repairs or other actions required are performed by organizational-level maintenance or above.

Calendar Inspection

All rescue hooks get a calendar inspection upon issue and at intervals to coincide with the aircraft cycle. In no case shall the intervals between calendar inspections exceed 225 days. The calendar inspection consists of the following visual inspection:

1. Inspect for missing, bent, fractured or damaged components.
2. Check hardware for security of attachment, corrosion, wear, and ease of operation.
3. Check for sharp edges and projections.

Cleaning

Clean the rescue hook after every immersion in salt water. To clean the rescue hook, proceed as follows:

1. Clean devices with an acceptable cleaning agent.
2. Remove all foreign objects with low-pressure air.
3. Lubricate all moveable parts of the rescue hook. Wipe off excess lubricant with a clean, dry, lint-free cloth.
4. Return the rescue hook assembly to service.

HOIST QUICK-SPLICE PLATE

The hoist quick-splice plate is made of 1/4-inch aluminum, 6 5/8 inches in length by 3 inches wide. The corners are rounded off and holes are grooved in places where the hoist cable rests. A stainless steel clip, 1/32 inch thick, is attached to the plate with two, 5/32-inch steel rivets. A rescue hook is attached to the plate with thimbles, swaging sleeve, and a length of hoist cable. The distance between the rescue hook and the plate is 6 inches. (See figure 5-21.)

The hoist quick-splice plate is used when the hoist cable is cut or broken during a rescue operation. It is used when time is a factor and no other means are available for rescue.

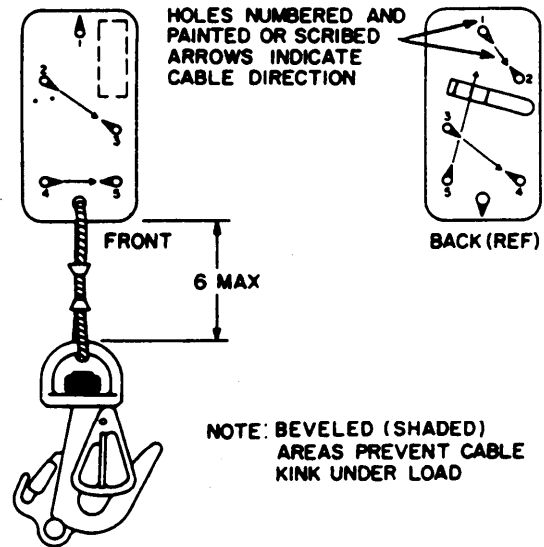

Figure 5-21.—Hoist quick-splice plate.

239.410

Maintenance

The aircrewman's responsibility for maintenance of the hoist quick-splice plate is limited to giving it a freshwater wash. Repairs or other actions are performed by organizational-level maintenance or above.

Calendar Inspection

All hoist quick-splice plates are given a calendar inspection upon issue and at intervals of 225 days. The calendar inspection consists of a visual inspection for bends, corrosion, sharp edges, and projections.

Cleaning

You have to clean the hoist quick-splice plate after every immersion in salt water. To clean it, proceed as follows:

1. Clean with an acceptable cleaning agent.
2. Dry with a lint-free cloth.

CABLE GRIP

The cable grip (which opens and closes on the cable) and a shackle enable the cable grip to be attached to the crewman's safety belt to take the weight off the hoist assembly during a hoist

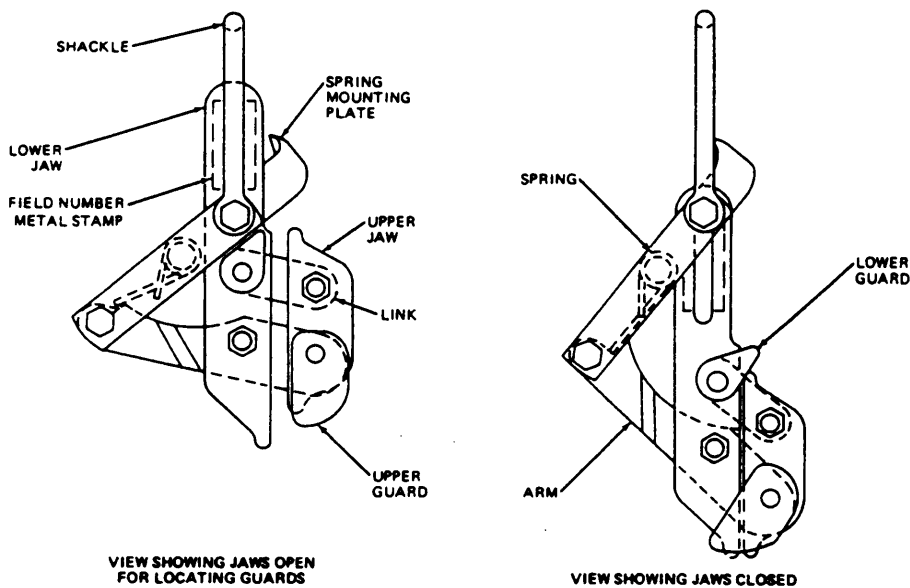

Figure 5-22.—Cable grip.

239.411

failure. The cable grip is capable of supporting 1,000 pounds. (See figure 5-22.)

The cable grip is an emergency condition device used by personnel performing rescue operations from a helicopter when the rescue hoist has a malfunction that renders the hoist inoperable. The cable grip is used for quick temporary attachment to the hoist cable.

Maintenance

The aircrewman's responsibility for maintenance of the cable grip is limited to a freshwater wash and to informing maintenance control that it has been used. Repairs or other actions required are performed by organizational-level maintenance or above.

Calendar Inspection

All cable grips are subject to a calendar inspection upon issue and at intervals of 225 days. To inspect the condition of the cable grip, proceed as follows:

1. Inspect for missing, bent, fractured or damaged components.
2. Check hardware for security of attachment, corrosion, wear, and ease of operation.
3. Check for sharp edges and projections.

Cleaning

Clean the cable grip every time it has been immersed in salt water. To clean it, proceed as follows:

1. Clean devices with an acceptable cleaning agent.
2. Remove all foreign objects with low-pressure air.
3. Lubricate all movable parts of the cable grip with lubricating oil. Wipe off any excess oil with clean, dry, lint-free cloth.

PNEUMATIC RESCUE HAND TOOL

The pneumatic rescue hand tool is a cartridge-operated device. A chamber within the handle secures a 3,000 psi nitrogen gas cylinder, which provides a very powerful force against the cutting blade.

The case is made of nylon webbing, 12 1/2 inches long and 5 3/4 inches wide at the top, tapering to 3 1/4 inches wide at the bottom. A 46-inch lanyard and baby swivel hook, attached to the upper grommet, are designed for

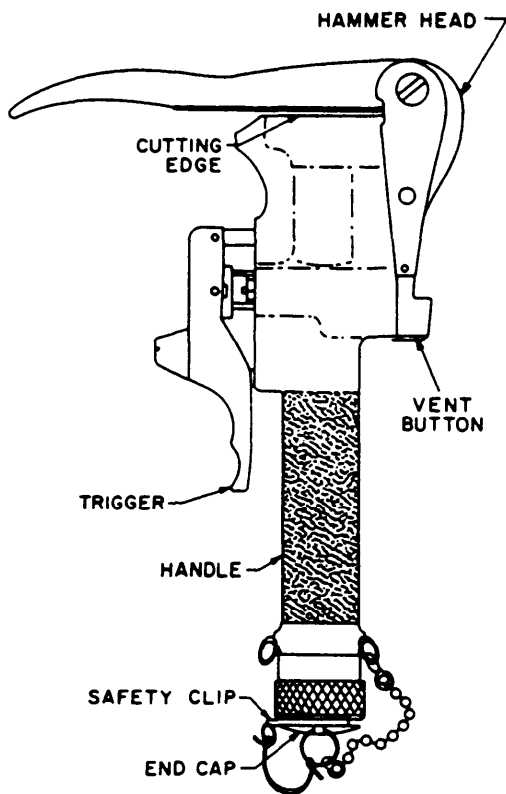

239.412

Figure 5-23.—Pneumatic rescue hand tool.

attachment to the pneumatic rescue hand tool. (See figure 5-23.)

The pneumatic rescue hand tool is designed for helicopter rescue crewman to use during air/sea rescue operations.

The pneumatic rescue hand tool gives the crewman a readily available cable cutter and parachute harness webbing cutter. The tool can cut single strands of stainless steel cable up to 7/32 inch in diameter as well as harness webbing of thickness up to and including 1/4 inch and widths up to 1 3/4 inch, in single cuts. The pneumatic rescue hand tool, complete with case, should be readily available to the rescue crewman during rescue operations.

Maintenance

The aircrewman's maintenance of the pneumatic rescue hand tool is limited to a freshwater rinse. Repairs or other maintenance action required are done by organizational-level maintenance or above.

Calendar Inspection

The pneumatic rescue hand tool is inspected upon issue and at intervals not to exceed 225 days. The calendar inspection consists of a visual inspection and a functional test. To perform a visual inspection, proceed as follows:

1. Inspect all parts for corrosion, cracks, wear, and any other defects.
2. Inspect blade for sharpness. Sharpen, using an appropriate whetstone, or replace as necessary.
3. Inspect the anvil for scored surface.

The functional test consists of the following tasks:

1. Leakage test. To perform a leakage test, proceed as follows:
 - a. Pressurize the hand tool to 3,000 psi with a nitrogen cartridge.
 - b. Immerse the pressurized hand tool in fresh water and rotate the tool in three directions to eliminate any trapped air in external pockets.
 - c. Any leakage after 1 minute indicates a defective seal of the component from which the gas is escaping. Replace seals as necessary.

2. Trigger force test. To perform a trigger force test, proceed as follows:
 - a. Mount the pressurized hand tool in an appropriate fixture, cradle or V-block.
 - b. Using a push-pull scale, measure the trigger force necessary to actuate the blade on the first stroke. The force is applied midway on the finger area of the trigger. Two thicknesses of Type XIII, MIL-W-4088C, webbing should be cut. The trigger force is between 5 and 20 pounds. Trigger force outside this range indicates the need for repair of the trigger (forward) valve or the trigger assembly.

3. Performance. To conduct a performance test, proceed as follows:
 - a. Cut a double thickness of webbing, and with the trigger in the depressed position, immerse the hand tool in water.
 - b. Any leakage after 1 minute of immersion indicates the piston seal leaks or the exhaust (rear) valve leaks.
 - c. Make 10 additional double webbing cuts. After the tenth cut, with the trigger depressed, immerse the hand tool in water.

d. Check for leakage during 1 minute of immersion. Any leakage indicates the trigger (forward) valve is faulty.

e. Make additional cuts of double webbing until the hand tool fails to cut through both thicknesses. The total number of cuts should exceed 10.

f. Failure to make 10 cuts indicates maintenance is required.

Cleaning

Clean the pneumatic rescue hand tool after every immersion in salt water. To clean, proceed as follows:

1. Rinse the hand tool thoroughly in fresh water (preferably distilled) and air dry, using a forced warm air source.

2. After cleaning the hand tool, lightly coat the cutting edge of the blade with pneumatic grease.

CHAPTER 6

INFLATABLE SURVIVAL EQUIPMENT

Learning Objective: Upon completion of this chapter, you will be able to recognize, inspect, and maintain inflatable survival equipment.

Since naval air operations are predominantly over water, the Navy has developed highly reliable and versatile inflatable equipment designed to meet the needs of aircrew personnel in a water survival situation.

The versatility seen in current inflatable survival equipment meets the ever increasing and diverse needs of the fleet. For example, the life preserver provides more than enough buoyancy to support a person with all survival gear donned, but not sacrifice comfort or adversely restrict movement in the water. It does not interfere with the aircrew member's ability to perform his/her duties aboard the aircraft. The life preserver is flame resistant, lightweight, and has the capability to contain certain survival items. The life preserver is reliable and will save a life, if used properly.

Life rafts provide protection from the cold and hostile environment of the sea. For single- and dual-seat aircraft, a one-man life raft adequately fulfills this function. However, for large aircraft, the 4-, 7-, 12-, or 20-man life rafts will be used. In addition to providing protection from the environment, these rafts carry an adequate number of survival items for their capacity, but are still light enough to carry.

Naval aircraft making operational flights over water are required to carry rafts that will accommodate all the assigned crew, plus passengers. These rafts are manufactured in various sizes and configurations to meet the demands of all type of aircraft.

Pneumatic rafts are compact assemblies, which can be stowed in a small area. They should be stowed so they are readily accessible, preferably near an emergency exit. Never stow a raft under other equipment or cargo or near batteries. Protect them from heaters, engines, auxiliary power units, electronic tubes, or other sources of heat.

If the aircraft flight manual designates a storage place for rafts, this space will be used, unless you are otherwise directed by competent authority. Whenever possible, stow rafts in the same manner in all aircraft of the same model. This enables the crew to become familiar with their location, and thus avoid confusion in the event of a ditching.

Rafts are constructed of rubber-impregnated nylon fabric; therefore, they are susceptible to damage from maltreatment. However, when afloat at sea, they are surprisingly strong and durable, and have a tenacious stability. It is your responsibility as a PR to inspect, pack, and maintain all of the various types of rafts and related equipment carried in aircraft.

INSPECTIONS

All inflatable survival equipment will be subjected to periodic maintenance under the direction and control of the maintenance/material control officer of the activity to which the equipment is assigned. Maintenance must be thorough at all times. No instance of careless treatment or willful neglect of inflatable survival equipment will be allowed to go unnoticed. The vital function of this equipment must be uppermost in the minds of all personnel concerned. The periodic inspection cycles should coincide with the specific aircraft inspection cycles specified in OPNAVINST 4790.2 (series), or personal issue equipment cycle, as applicable.

To meet unusual situations and aid workload scheduling, a period of plus or minus 1 week, or portion thereof, may be applied to the authorized inflatable survival equipment calendar maintenance interval. A period of plus or minus

10% may be applied to equipment in phased maintenance aircraft.

The five different types of life rafts used in naval aviation are the LR-1 and LRU-7/P, which are one-man rafts; the LRU-12/A, which is a four-man raft; the LRU-13/A, which is a seven-man raft; the LRU-14 series, which is a 12-man raft, and the LRU-15/A, which is a 20-man raft.

You may be required to work on only one or you may work on all of them. All require the same three inspections—preflight, special, and calendar/phase.

The preflight inspection is performed on fuselage-installed life rafts before the first flight of the day. This inspection is done by line personnel (plane captain or delegated aircrewman) who have been designated by the line division officer, instructed, and found qualified by the aviators equipment branch.

The special inspection is performed on fuselage-installed life rafts every 30 days. This inspection is made at the organizational level of maintenance by personnel assigned to the aviators equipment branch. Upon completion of the inspection, the date of inspection and inspector's signature are entered in the inspections section of the Aviation Crew Systems History Card.

To perform a preflight/special inspection, visually inspect for the following:

1. Fabric for cuts, tears, deterioration, and abrasion
2. Seams for proper adhesion or stitching
3. Straps and handles for security and wear
4. Any other parts for wear, damage, and security
5. All hardware for security of attachment, corrosion, damage, wear, and, if applicable, ease of operation
6. Life raft retaining line for proper stowage

CAUTION

DO NOT OPEN RAFT ACCESS DOORS, RSSK KITS, OR ANY SEALED OR SAFETY-WIRED PORTION OF THE LIFE RAFT FOR THIS INSPECTION.

Subject each life raft to the **calendar/phase inspection** before you place it in service, or if it is an aircraft inventory item at the time of the aircraft acceptance inspection. Thereafter, the calendar/phase inspection interval coincides with

the aircraft inspection cycle in which it is installed. See the applicable Planned Maintenance System (PMS) publications for specific intervals. In no case will the interval exceed 231 days except that the LR-1 (RALSA) inspection is not to exceed 453 days. Unless operational requirements demand otherwise, the life raft calendar/phase inspection is performed at the intermediate level of maintenance or above.

The acceptance/calendar/phase inspection consists of the following major tasks (to be performed in the order listed):

1. Container/case inspection
2. Functional test (if required)
3. Pull cable proof load test (if required)
4. Visual
5. Inflation assembly inspection
6. Leakage
7. Records updating
8. Repacking

Details are listed in NAVAIR 13-1-6.1.

A functional test and pull cable proof load test are performed prior to placing a raft in service or during an aircraft acceptance inspection, and each fourth inspection cycle thereafter. You must make a leakage test at each inspection cycle. If the inspection indicates any damage beyond capability of maintenance, you must forward the entire assembly to supply.

DETERMINATION OF REPAIRABILITY

Life rafts are considered beyond repair for any of the following reasons:

1. Porous fabric areas on tubes
2. Split or open tube seams
3. Leakage test failure resulting from other than a cut, tear, or puncture
4. Damaged or malfunctioning inlet valve, manifold, or oral inflation tube
5. Damaged or malfunctioning topping-off valve that cannot be corrected by replacement of the topping-off valve opening insert
6. Multiplace rafts (leaky bulkheads)

FUNCTIONAL TEST

Before functionally testing a life raft, you should make sure you have enough area to inflate

the life raft. Remember to take into consideration the inflated size of the raft; an LRU-15/A will take 20 times the area that an LR-1 requires.

To begin the test, you first open the carrying case and unfold the life raft. All life rafts have an inflation assembly, and by pulling an actuating cable, you automatically inflate the raft with CO₂.

When you do this, the raft should inflate to design shape, without evidence of restriction, in less than 1 minute. This is a CDI inspection point, so have a CDI inspector watching before you pull the cable. Once the raft is inflated, examine it for obvious defects such as cuts, tears, ruptured seams, and damaged manifold.

PULL CABLE PROOF LOAD TEST FOR MULTIPLACE RAFTS

The pull cable proof load test for multiplace rafts is done in conjunction with the functional test. Also, the test must be performed prior to placing an inflation assembly into service. First remove the inflation valve cover plate and remove the pull cable from the valve. Then apply a 50-pound pull force between the cable ball and the snap hook to determine if the cable is strong enough for the system.

Examine the pull cable for broken strands of wire, deformed snap hook, security of snap hook spring latch attachment, and loose or cracked swage fittings. If any damage is found, the pull cable is discarded and replaced with a new cable. The new cable is also tested. If the snap hook

spring latch is loose, it may be repaired in accordance with instructions contained in NAVAIR 13-1-6.1.

If the pull cable passes this test, reinstall the cable. Refer to NAVAIR 13-1-6.1 for details of installation.

LEAKAGE TESTING

The only way that you can be sure that a life raft does not have a leak is to perform a leakage test. To test the LRU-15/A with a vented Y-manifold for leakage, you must ensure that either the manifold inlet is capped or an empty cylinder is installed and the manifold inlet is in the CLOSED position. Install an equalizer tube clamp. These procedures are necessary for this raft due to its design. The LRU-15/A has two flotation tubes; one is on top of the other. The equalizer tube allows CO₂ or air pressure to enter both tubes at the same time. If you fail to cap the inlet, you will not be able to hold the pressure within the flotation tube. If you don't use an equalizer clamp, you will blow up both flotation tubes.

NOTE: Flotation tubes must be tested separately to determine internal vertical bulkhead leakage.

All multiplace life rafts are filled with air pressure through the topping-off valves. The LR-1 is inflated through an oral inflation tube.

After you have reached the test pressure (table 6-1), shut off the air supply and wait 15 minutes.

Table 6-1.-Life Raft Test Pressures

Raft type	Compartment	Leakage test pressure (psig)	Minimum pressure (psig)
LR-1	Raft Tube	2.0	1.60
LRU-7/P	Raft Tube	2.0	1.60
LRU-12/A and LRU-13/A	Bow Section	2.0	1.60
	*Inflatable Seat	1.0	0.60
	*Stern Section	2.0	1.60
LRU-14 SERIES	Bow Section	2.0	1.60
	Stern Section	2.0	1.60
	*Upper Tube	1.0	0.60
	*Inflatable Floor Sections	1.0	0.60
	*Inflatable Seat	1.0	0.60
LRU-15/A	*Upper Tube	3.0	2.60
	*Lower Tube	3.0	2.60
	*Floor Support Tube	2.0	1.60
*Compartments may be tested simultaneously			

Table 6-2.—Example of Temperature and Barometric Pressure Check

UNCORRECTED TEST READING 1.70 PSI

	TEMP.	BARO.
START	75°F	29.90 IN. Hg
END	70°F	29.70 IN. Hg
DIFFERENCE	- 5°F	-.20
CORRECTION	+ .155	-.098

TEMP. CORRECTION	+ .155
+ BARO. CORRECTION	- .098
CORRECTION	+ .057

UNCORRECTED READING	1.700 PSI
+ CORRECTION	+ .057
CORRECTED READING	1.757 PSI

Table 6-3.—Temperature Conversion Chart

Temperature Difference (Degree F.)	Correction (psi)
1	0.031
2	0.062
3	0.093
4	0.124
5	0.155
6	0.186
7	0.217
8	0.248
9	0.279
10	0.310

Rise in temperature: subtract from gauge reading.
Fall in temperature: add to gauge reading.

After 15 minutes, adjust the air pressure if necessary. At this time you must record the temperature and barometric pressure. This is done because any drop or rise in temperature or pressure affects the pressure within the flotation tube. Allow the raft to remain undisturbed for a minimum of 4 hours. At the end of 4 hours, check and record the test pressure and again record the temperature and barometric pressure.

See table 6-2 for an example. By using the conversion charts in tables 6-3 and 6-4, you can determine the correct reading for your raft. If your test pressure is within limits, you are ready to deflate the raft and repack the assembly. If the raft should fail this test, you must determine the cause. Information on testing for leaks can be found in chapter 2 of NAVAIR 13-1-6.1.

CLEANING

As you work on survival equipment you find that cleanliness is very important. It gives the equipment a longer service life, and it reassures the aircrewman that he is using an operational piece of equipment. If he sees a dirty life raft, he may think it is old and that it might leak. To clean life rafts, prepare a solution of cleaning compound (MIL-C-25769) consisting of one part compound and three parts water. Apply the cleaning solution to soiled area with a spray or sponge. Allow the solution to remain on the surface for several minutes, then rub with a soft brush or rag. Rinse the surface thoroughly with water and wipe with a cloth or sponge. Repeat this application until the surface is free from all solution. Dry the raft with a lint-free cloth, and apply a light coating of talcum powder.

HYDROSTATIC TEST OF CO₂ CYLINDERS

Every 5 years you must hydrostatically test the carbon dioxide cylinders used on multiplace life rafts. However, fully charged cylinders are considered serviceable regardless of the last hydrostatic test date. If a cylinder is both due for a test and discharged, disconnect it from the raft. Obtain a new cylinder from supply as a replacement. Forward the old cylinder to supply. (Cylinders must be empty before forwarding to supply.) Before installing the new cylinder, perform the following tasks:

1. Gently tap the inverted cylinder with a small piece of wood. If any rust or other contamination falls from the cylinder, do not use it. Draw another from supply and repeat the contamination check.
2. Ensure that a siphon tube is installed on all multiplace life raft cylinders.
3. Replace the stem in the inflation assembly valve.
4. Install a new sealing washer. Refer to NAVAIR 13-1-6.1.

Table 6-4.—Barometric Pressure Conversion Chart

Press. Diff. (inHG)	Corr. (psi)	Press. Diff. (inHG)	Corr. (psi)	Press. Diff. (inHG)	Corr. (psi)	Press. Diff. (inHG)	Corr. (psi)	Press. Diff. (inHG)	Corr. (psi)
.01	.005	.16	.078	.31	.152	.46	.225	.61	.299
.02	.010	.17	.083	.32	.157	.47	.230	.62	.304
.03	.015	.18	.088	.33	.162	.48	.235	.63	.309
.04	.020	.19	.093	.34	.167	.49	.240	.64	.314
.05	.025	.20	.098	.35	.172	.50	.245	.65	.319
.06	.030	.21	.103	.36	.176	.51	.250	.66	.323
.07	.035	.22	.108	.37	.181	.52	.254	.67	.328
.08	.040	.23	.113	.38	.186	.53	.260	.68	.333
.09	.045	.24	.118	.39	.191	.54	.265	.69	.338
.10	.049	.25	.123	.40	.196	.55	.270	.70	.343
.11	.054	.26	.127	.41	.201	.56	.275	.71	.348
.12	.060	.27	.132	.42	.206	.57	.279	.72	.353
.13	.064	.28	.137	.43	.211	.58	.284	.73	.358
.14	.069	.29	.142	.44	.216	.59	.289	.74	.363
.15	.073	.30	.147	.45	.221	.60	.294	.75	.368

Rise in pressure: add to gauge reading.
Fall in pressure: subtract from gauge reading.

- Thread the inflation valve onto the cylinder and tighten it to a torque value of 600 ± 60 inch-pounds for multiplace life raft cylinders and 400 ± 40 inch-pounds for LR-1 raft cylinders. **The hydrostatic test does not apply to the LR-1 life raft cylinder.**

MULTIPLACE RAFTS

Multiplace life rafts vary in size and in the quantity of equipment they carry.

CNO has established survival equipment lists as standards to be used by all concerned. These lists provide the equipment necessary for an effective 24-hour survival capability.

The body of the life raft consists of an encircling buoyant tube and a fabric bottom. The fabric sections used in the inflatable buoyant tube are incorporated in such a manner that the warp threads of the straight fabric run in a circumferential direction around the tube, and the warp threads of the bias cloth run in the opposite direction in the adjoining sections.

The fabric bottom of the raft is applied without tension across the enclosure formed by

the flotation tube, and it is attached securely to the underside.

SEAM TAPES AND PATCHES

All raft seams and patches are secured by the use of self-curing cement, applicable to the specifications listed in the *Inflatable Survival Equipment Manual*, NAVAIR 13-1-6.1.

No sewing or stitches are used in the seams or through the fabric of any compartment. However, sewing is permitted in the construction of patches, oarlocks, disks, flap seats, cylinder carriers, lifeline supports, handles, and pockets.

Seam repair is done only if a flotation tube does not leak; that is, if only the outer seam tape is loose or if the seam does not seal a flotation tube. If the seam tape is present and undamaged, recement the tape to the raft. If the tape is missing, measure and fit a replacement tape to the area and cement it in place. Overlap the seam tape on other seams a minimum of 1 inch.

If the tape is damaged, peel the tape from the raft. Apply toluene only as needed to loosen the tape. Avoid excessive application of toluene on the seams, and remove any spilled or excess toluene immediately.

NOTE: Do not use toluene near open flame, heat, or electrical sparks. Avoid prolonged contact with the skin or breathing the fumes. Use toluene only in well ventilated areas.

Do not touch the cleaned raft areas when handling. Clean both the pieces to be cemented with four applications of toluene. Apply the toluene with back-and-forth strokes on the first and third applications and one-way strokes on the second and fourth. Allow the areas to dry between applications.

Prepare cement and accelerator mixture. Prepare only enough mixture to last for 8 hours, as this is the effective active period for the mixture. Dispose of any remaining mixture after 8 hours.

Using a disposable brush, apply cement to completely cover surfaces to be cemented.

Apply two coats of cement to both pieces, allowing the first coat to dry for approximately 10 minutes.

When the second coat of cement becomes tacky, place the pieces together. If the cemented area is a cut or tear, butt the edges of the damaged area before applying a patch. Roll out the bubbles using a wooden roller.

Allow the cemented area to dry for at least 48 hours, and then dust the area with talcum powder.

If the seam tape is only damaged, trim the old tape and replace it with new tape. Overlap the other seam tape a minimum of 1 inch. All tapes and patches are applied to the life raft without tension. The tape is applied in such a way that an equal amount of tape width is on each side of the seam edge, which it covers.

To patch a damaged area on a life raft, select the applicable color and type of raft cloth, depending on the type of raft to be repaired. Cut a rounded patch 1 inch larger than the damaged area on all sides. Scallop the edges of the patch if it is larger than 5 inches in diameter.

If the damaged area in the floor is larger than 1 inch, patches must be applied to both sides. Intermediate maintenance activities have the

prerogative to declare rafts beyond the capability of maintenance if internal patching is required.

Center the patch over the damaged area and trace an outline of the patch on the raft fabric.

Cement the patch to the damaged area in accordance with the instructions previously discussed in this section. After all repairs have been made, perform a leakage test on the raft and dust the repaired area with talcum powder.

BULKHEADS

The flotation tube is separated into two compartments by internal vertical bulkheads. Bulkheads are constructed of laminated cloth and are of a six-gore hemispherical design. The bulkheads are installed amidships, equidistant from the bow and stern so that the volume of the two compartments is equal. A 4-inch-diameter patch of laminated cloth is securely cemented to each side of the bulkhead, at the manifold, to protect the bulkhead against abrasion by the manifold diffusers when the raft is packed in the carrying case.

INFLATABLE SEATS

An inflatable seat is installed in certain multiplace life rafts; for example, the LRU-12/A, LRU-13/A, and LRU-14 series. These seats are circular and are made of laminated cloth. The ends of the seat are tailored to fit the curvature of the flotation tube. The inflatable seat is an independent air chamber and is manually inflated through the topping-off valve by using the hand pump provided. It is attached to the bottom of the raft with Y-shaped hinge tapes made of laminated cloth. This method of attachment allows for expansion and prevents undue stresses between the bottom of the raft and the seat.

SUPPLY POCKET

Each LRU-12/A, LRU-13/A, and LRU-14 series life raft contains a supply pocket that measures approximately 8 x 8 x 2 inches. The pocket is attached to the starboard side of the flotation tube surface inside the raft by stitching the pocket to a patch and cementing the patch to

the tube. Using black washproof ink, ensure that each pocket is clearly marked SUPPLY POCKET in 1/2-inch letters on the LRU-12/A and LRU-13/A rafts. The lettering should be 1-inch high on the LRU-14 series supply pocket.

In addition to the starboard supply pocket, the LRU-14 series raft has a port supply pocket. This pocket is attached to the raft in the same manner as previously discussed. The lettering height on the port pocket is 1 inch for the first line and 1/4 inch for all other lines.

COMBINATION SUPPLY POCKET AND BAILER

Each life raft, except the LRU-15/A, contains one detachable combination supply pocket and bailer. The pocket is closed by means of a slide fastener across the top, which is sealed with tape after the equipment is packed. A loop of spring wire is contained in the seam around the slide fastener so that the pocket may be fashioned into a bailing container. One end of a 5-foot length of type III nylon suspension line is secured to the slide fastener wire stirrup pull; the other end is attached to the nearest lifeline patch loop.

The words SUPPLIES AND BAILER are stenciled in 1/2-inch letters on the pocket. Below this, stenciled in 1/4-inch letters, are the pocket contents.

The Supply and Bailer pocket on the STBD side of LRU-12/A, -13/A, and -14 series has been deleted from newly procured rafts. New rafts are not reworked to provide pocket and on older rafts they need not be removed.

LIFELINE

A lifeline of natural color nylon rope, 1/4-inch diameter, encircles the outboard perimeter of the raft. The lifeline is attached to each lifeline patch loop with an overhand knot tied on the inner side of each patch loop so as to prevent the line from running free through the loops. Four inches of slack is allowed in the line between the lifeline patch loops. Each completed lifeline patch can withstand a 250-pound pull exerted in a direction perpendicular to the base of the patch.

The lifeline provides a means for securing the accessory containers to the life raft by using a 10-foot length of type 111 nylon cord.

The LRU-15/A life raft also has an inner lifeline that provides for the safety and survival of aircrewmembers.

RIGHTING HANDLES

Righting handles are provided on all life rafts except the LRU-15/A. These handles provide a means of righting a capsized raft.

TOPPING-OFF VALVES

Topping-off valves are installed on each flotation tube, inflatable seat, each section of inflatable floors, and each side of the floor supports. The required number of topping-off valves and their location on the rafts may vary depending on the type of raft concerned.

Topping-off valves are used for manual inflation purposes in conjunction with the hand pump. The valve also serves as a means for relieving high internal tube pressure that may possibly build up during hot, sunny days.

Two topping-off valves are installed on the same side of the raft's main flotation tube—one on each side of the internal bulkhead—above the inside horizontal centerline of the tube, 4 inches from the point of attachment of the vertical internal bulkhead.

Stenciled instructions relative to topping-off and deflation of the raft are applied on the raft flotation tube adjacent to the topping-off valves. Appearing in 1/4-inch, washproof black ink letters, the instructions are stenciled on a white rubber patch as follows:

TO INFLATE COMPARTMENTS MANUALLY: Attach hand pump to valve cap, unscrew cap 1 1/2 turns to the right and then pump to inflate. When desired pressure is attained, retighten valve cap and remove pump.

TO DECREASE PRESSURE: Open valve
1 1/2 turns to the right and bleed.

INFLATION SYSTEM

The valve of the CO₂ cylinder is threaded into the coupling nut of the manifold. Since multiplace life rafts are constructed with internal bulkheads, the purpose of the manifold is to provide a common means of directing and diffusing the flow of carbon dioxide entering the raft's inflatable tube chamber. The manifold outlets must bridge the internal bulkhead over which they are mounted. Figure 6-1 illustrates the operation of the raft's CO₂ inflation system manifold.

All of the exposed metal surfaces of the inflation system that might chafe the raft fabric while packed must be covered with several layers of rubber-coated cloth, and secured with cloth-based, pressure-sensitive tape.

Because of space limitation, this chapter cannot possibly contain all of the available information concerning life rafts. *The Inflatable Survival Equipment Manual*, NAVAIR 13-1-6.1, is referenced for more detailed information.

LRU-12/A LIFE RAFT ASSEMBLY

The LRU-12/A life raft assembly consists of an inflation assembly (carbon dioxide cylinder and inflation valve) and a four-man raft. Two types of carbon dioxide cylinders and four types of inflation valves are approved for service use. The life raft is made up of a two-compartment main tube; an inflatable seat attached to the main tube; a noninflatable floor attached to the bottom of the main tube and inflatable seat; and a sea anchor, which is used to retard drifting. A lifeline, a righting line, a supply pocket, and a combination supply pocket and bailer are attached to the main tube.

Boarding and righting handles are attached to the main tube and the floor. Emergency survival equipment and raft accessories, stowed in accessory containers, are provided for the safety and survival of the aircrewmembers. The lifeline also provides a means for securing the accessory containers to the life raft. Topping-off valves are located on the main tube and inflatable seat. An LRU-12/A life raft is shown in figure 6-2.

NOTE: To makeup the packaged life raft assembly complete with accessories and survival items, all required components not supplied with the raft assembly must be individually requisitioned.

The LRU-12/A life raft assembly (droppable) is inflated by pulling the inflation assembly actuating handle, located under the carrying case end flap. The LRU-12/A life raft assembly (raft compartment installation) is automatically inflated and ejected after the raft compartment door has been released. After boarding, the inflatable seat should be inflated through the topping-off valves with the hand pump provided in the accessory container.

The LRU-12/A life raft assembly can either be dropped to survivors or used by aircrewmembers in the event of an aircraft ditching emergency. The raft is stowed in a readily accessible area inside the aircraft fuselage on all applicable aircraft except the S-2 series.

Prior to packing any life raft, the assembly must be updated by comparing the configuration of the assembly with the modifications listed in the applicable chapter in NAVAIR 13-1-6.1.

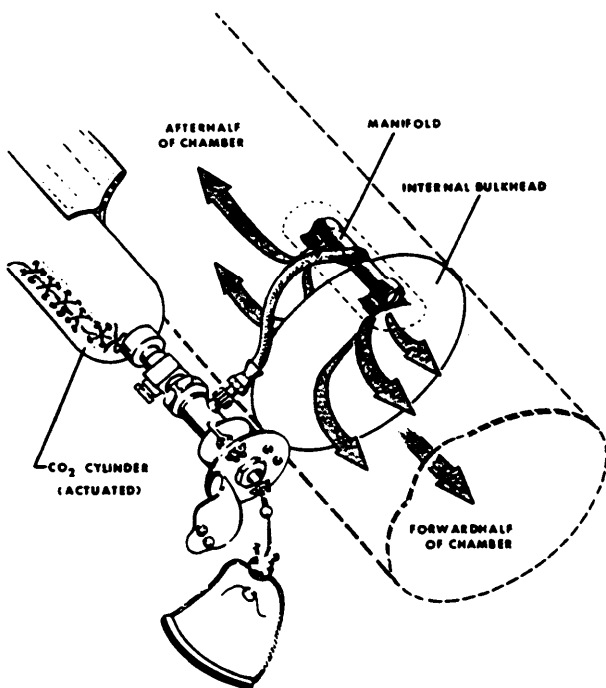

239.338

Figure 6-1.—Multiplace raft CO₂ inflation system manifold operation.

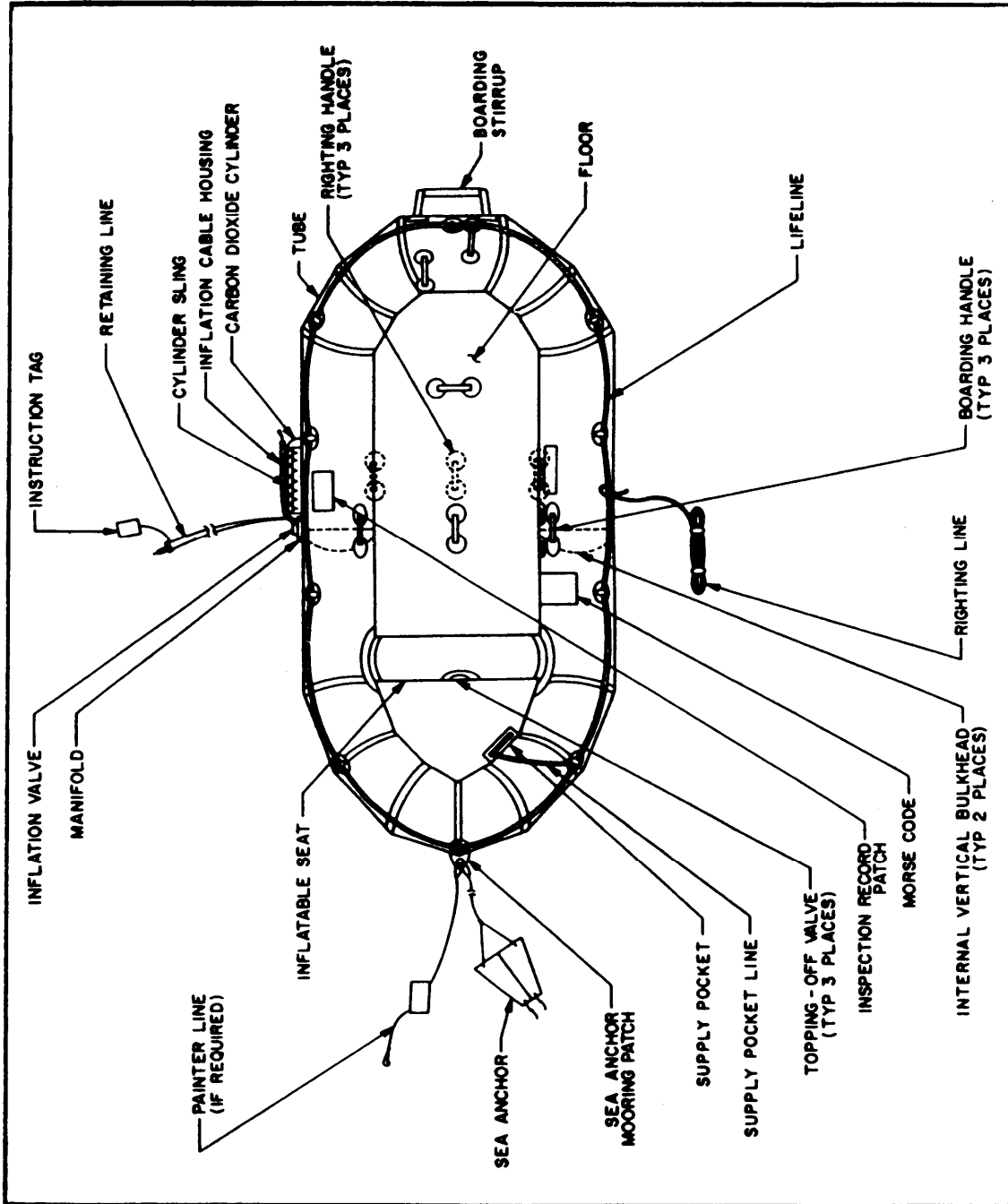

239.339

Figure 6-2.—LRU-12/A life raft assembly, parts nomenclature.

Survival items are intended to provide a means for sustaining life, aiding in escape and evasion, and for a suitable detection capability. Survival items may be packed in life rafts, droppable kits, kits intended to be carried or worn by the aircrewmembers, or they may be individually carried.

The equipment and survival items carried in the LRU-12/A life raft assembly differ from that carried in other rafts basically in the quantity carried, with a few minor exceptions. Table 6-5 lists the survival item requirements and the applicable item storage container and pocket for LRU-12/A, LRU-13/A, LRU-14 series, and LRU-15/A life rafts.

LRU-13/A LIFE RAFT ASSEMBLY

The LRU-13/A life raft assembly consists of an inflation assembly (carbon dioxide cylinder and inflation valve) and a seven-man raft. Two types of carbon dioxide cylinders and four types of inflation valves are approved for service use. The life raft is made up of a two-compartment main tube; an inflatable seat attached to the main tube; a noninflatable floor attached to the bottom of the main tube and inflatable seat; and a sea anchor, which is used to retard drifting. A lifeline, a righting line, a supply pocket, and a combination supply bag and bailer are attached to the main tube. Boarding and righting handles are attached to the main tube and the floor. Emergency survival equipment and raft accessories are stowed in the accessory containers. The lifeline also provides a means for securing the accessory containers to the life raft. Topping-off valves are located on the main tube and the main seat. The LRU-13/A life raft assembly and parts nomenclature are the same as the LRU-12/A (shown in figure 6-2), except that the LRU-13/A is longer.

EQUIPMENT AND SURVIVAL ITEMS

The LRU-13/A life raft equipment and survival item requirements and the applicable storage container are listed in table 6-5.

PACKING PROCEDURES REMOTE OR LOCAL PULL

Prior to packing the LRU-13/A life raft assembly, it must be updated by comparing the configuration of the assembly with the modifications listed in NAVAIR 13-1-6.1.

The LRU-13/A life raft assembly may be packed for droppable inflation, or for installation into the aircraft nacelle or raft compartment. The method used for packing depends upon the aircraft application.

NOTE: The inflation cable housing must not be inserted through the abrasion patch sleeve when folding and packing the raft. The cable housing should be inserted into the sleeve after the raft is inflated.

Here are the packing procedures for the LRU-13/A life raft assembly. These packing procedures apply to all methods of packing unless a specific method for either the droppable or local mode of inflation is specified in parentheses.

1. Ensure that the raft, carrying case, and accessory container have been inspected.
2. Ensure that the survival items and raft accessories have been inspected for expiration and damage. Refer to table 6-5 for items used.
3. Wrap all sharp or pointed metallic accessories and survival items with rubber-coated cloth, and secure the objects with rubber bands. Stow the accessories and survival items in the accessory container, or the supplies and bailer pocket, as applicable.
4. Cover the inflation valve with several layers of rubber-coated cloth, and secure it with cloth-based, pressure-sensitive tape. Take the webbing retaining line, righting line, and sea anchor mooring line and secure them with rubber bands. Ensure that all of the topping-off valves are closed and the raft is completely deflated.
5. Using a 10-foot length of type III nylon cord, tie the accessory equipment container to the nearest lifeline loop located next to the CO₂ cylinder, and stow the container inside the raft.

Table 6-5.—Life Raft Survival Item Requirements and Item Storage Containers for LRU-12/A, LRU-13/A, LRU-14 Series, and LRU-15/A Life Rafts

Description	Quantity required			
	LRU-12/A	LRU-13/A	LRU-14 SERIES	LRU-15/A*
<u>Packed In Accessory Container</u>				
Sea Dye Marker	3	4	5	6
Distress Signal, MK-13 MOD 0 (2) or Distress Signal, MK-124 MOD 0	4	6	8	10
Water Storage Bag (Size A)	2	3	4	7
Water, Drinking, Canned, Emergency	4	7	12	20
Opener, Can, Hand (8)	1	1	1	2
First Aid Kit, Size A	1	1	1	2
Sunburn Preventive Cream (1) or Sunburn Preventive Preparation	1	1	2	3
Food Packet, Liferaft	4	7	12	20
Bailing Sponge	1	1	2	2
Hand Pump, Type III	1	1	1	2
Combat Casualty Blanket Type I	1	1	2	3
Hand Generated Flashlight A-9(3)	1	1	1	1
Canopy Rib Assembly	—	—	3	—
Bailing Bucket	—	—	2	—
3 - Sectional Oars	—	—	2	—
Patch, Mechanical (10)	—	—	—	2
<u>Packed In Supply Pocket</u>				
Flare Gun, MK-79 MOD 0	1	1	1	2
Signal Light (Strobe) SDU-5/E	1	1	1	1
Signal Light (Steady Burning) SDU-30	1	1	1	1
Signal Mirror, Type I (4) or Signal Mirror, Type II	1	1	1	1
Survival Radio (5) (6) or Radio Beacon AN/URT-33A	1	1	1	1
Battery (9)	1	1	1	1
Code Card (7)	1	1	1	1
Whistle, Type II	1	1	1	1
Compass, Pocket, Type MC-1 (1) or Compass, Wrist	1	1	1	1
Pocket knife	1	1	1	1
Cord, Nylon, Utility, 50 feet	1	1	1	1

Notes:

- (1) No longer procured. This item should be utilized (in lieu of substitute item) until stock has been depleted.
- (2) The MK-13 shall be used until depleted. The MK-124 will replace the MK-13 as stock becomes available.
- (3) Required for Arctic missions; optional otherwise.
- (4) The Type II mirror (large) shall be utilized in lieu of the Type I mirror (small) until stock of the Type II mirror is depleted.
- (5) Stock levels may dictate a particular survival radio be used. This will be directed by the Area Commander. If no type survival radio is available, each liferaft shall have an AN/URT-33 beacon.
- (6) If PRT-5 transmitters are carried, they shall be packed in the accessory container.
- (7) Order from Naval Publications and Forms Center (refer to paragraph 1-12) (stock number 0800-LP-000-1500).
- (8) Wrap cutting edges with rubber-coated cloth and secure with a rubberband.
- (9) Ensure battery service life does not expire prior to the next scheduled calendar inspection. Refer to NAVAIR 16-30URT33-1 for battery service life.
- (10) Patch, mechanical, is made in accordance with MS27826-1, size 3 7/8 inches by 2 1/2 inches).

*All items packed in accessory container.

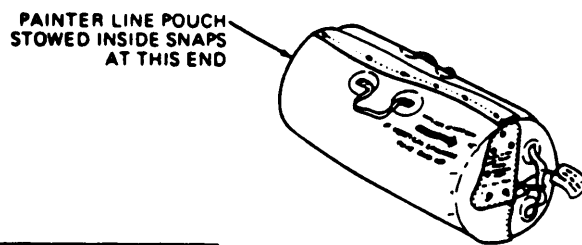
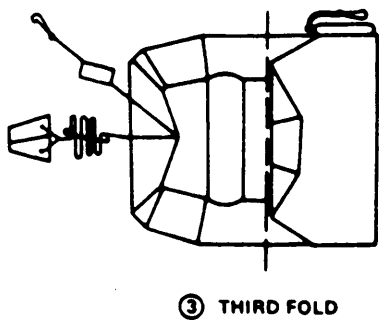
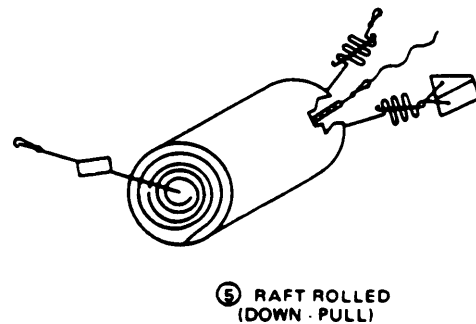
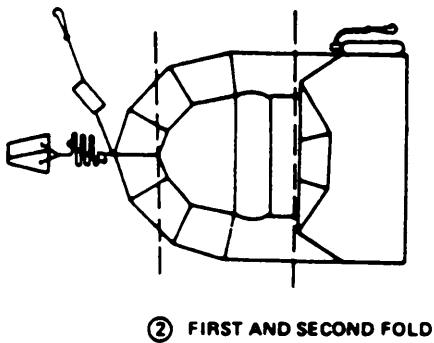
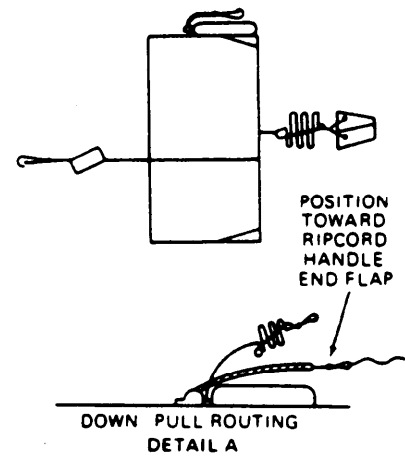
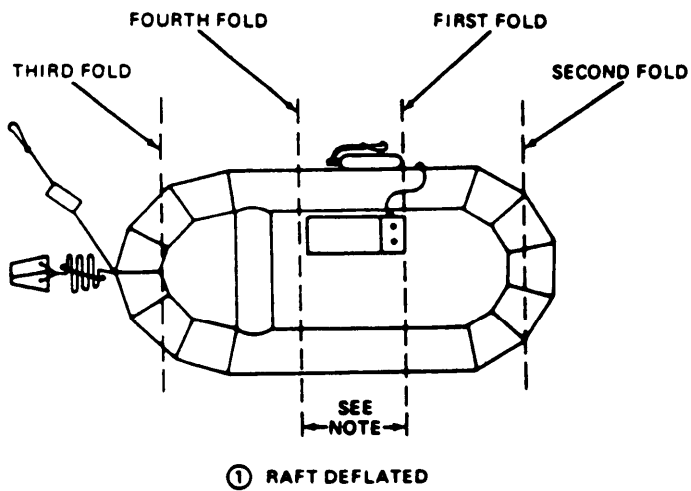

NOTE:

CARRYING CASE	CENTERFOLD
31 INCHES	30 INCHES
36 INCHES	35 INCHES

Figure 6-3.—LRU-13/A raft-folding procedures (droppable).

6. (Fold the raft in accordance with figure 6-3, for droppable inflation).

7. Insert the folded raft into the carrying case so that the actuating handle or pull cable housing is positioned under the carrying case end flap.

8. Secure the carrying case snap fasteners.

NOTE: If the actuator case snap hook is not soldered, wrap tape around the hook to prevent possible loss of the spring latch.

9. Rig the pull cable housing to the carrying case ripcord.

10. (Install the ripcord and safety tie the first and last ripcord pins by passing a 12-inch length of size E nylon thread under the ripcord pin). Secure the thread to the ripcord cable with three or four half-hitches (fig. 6-4).

NOTE: Rafts stowed inboard on aircraft are secured to the aircraft with a painter line. The painter line is a 60-foot length of cotton cord (unless otherwise specified by the applicable aircraft MIM), type I, size 4, with a 50- to 150-pound static breaking strength.

The painter line retains the deployed raft to the aircraft, but will easily break if the aircraft sinks. The painter line is attached to the sea anchor mooring patch loop unless otherwise specified by the applicable aircraft MIM. Stow the painter in the painter line pouch, and place the pouch under the packed raft if possible.

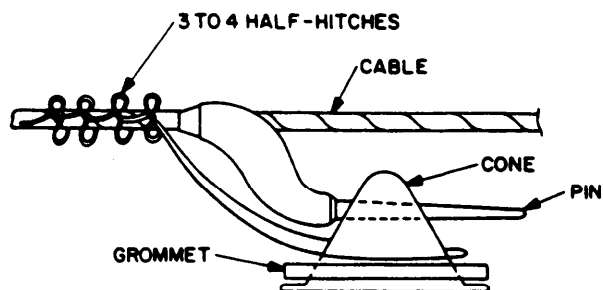

Figure 6-4.—Safety tying ripcord.

11. (Snap the ripcord protector flap closed, position the ripcord handle under the carrying case end flap, and snap the end flap closed).

12. (Ensure that the inflation valve actuating handle is positioned outside the carrying case end flap, and snap the end flap closed).

When the LRU-13/A life raft assembly is packed for installation into the aircraft nacelle or raft compartment, follow procedures outlined in the applicable aircraft MIM.

All LRU-13/A life raft assemblies installed in C-1 aircraft must be packed for down-pull inflation using the “snap hook” remote actuator assembly, which consists of a snap hook pull cable assembly and a pull cable housing assembly. In no instance should “ice-tong” remote actuator assemblies be used in C-1 aircraft.

LRU-14 SERIES LIFE RAFT ASSEMBLY

The LRU-14 series life raft assembly consists of an inflation assembly (carbon dioxide cylinder and inflation valve) and a 12-man raft. Two types of carbon dioxide cylinders and two types of inflation valves are approved for service use.

The life raft is made up of a two-compartment main tube; a smaller single-compartment upper tube, which is permanently attached to the top of the main tube; an inflatable seat attached to the main tube; a noninflatable floor attached to the bottom of the main tube and seat; a two-section inflatable floor tied to the inside of the non-inflatable floor; and a sea anchor, which is used to retard drifting.

A lifeline and a supply pocket are attached to the main tube. Boarding and righting handles are attached to the main tube and both floors. Survival equipment and raft accessories, stowed in the accessory container, provide for the safety and survival of the aircrewmembers. The lifeline also provides a means for securing the accessory containers to the raft. Topping-off valves are located on the upper tube, inflatable seat, and on both sections of the inflatable floor. The LRU-14

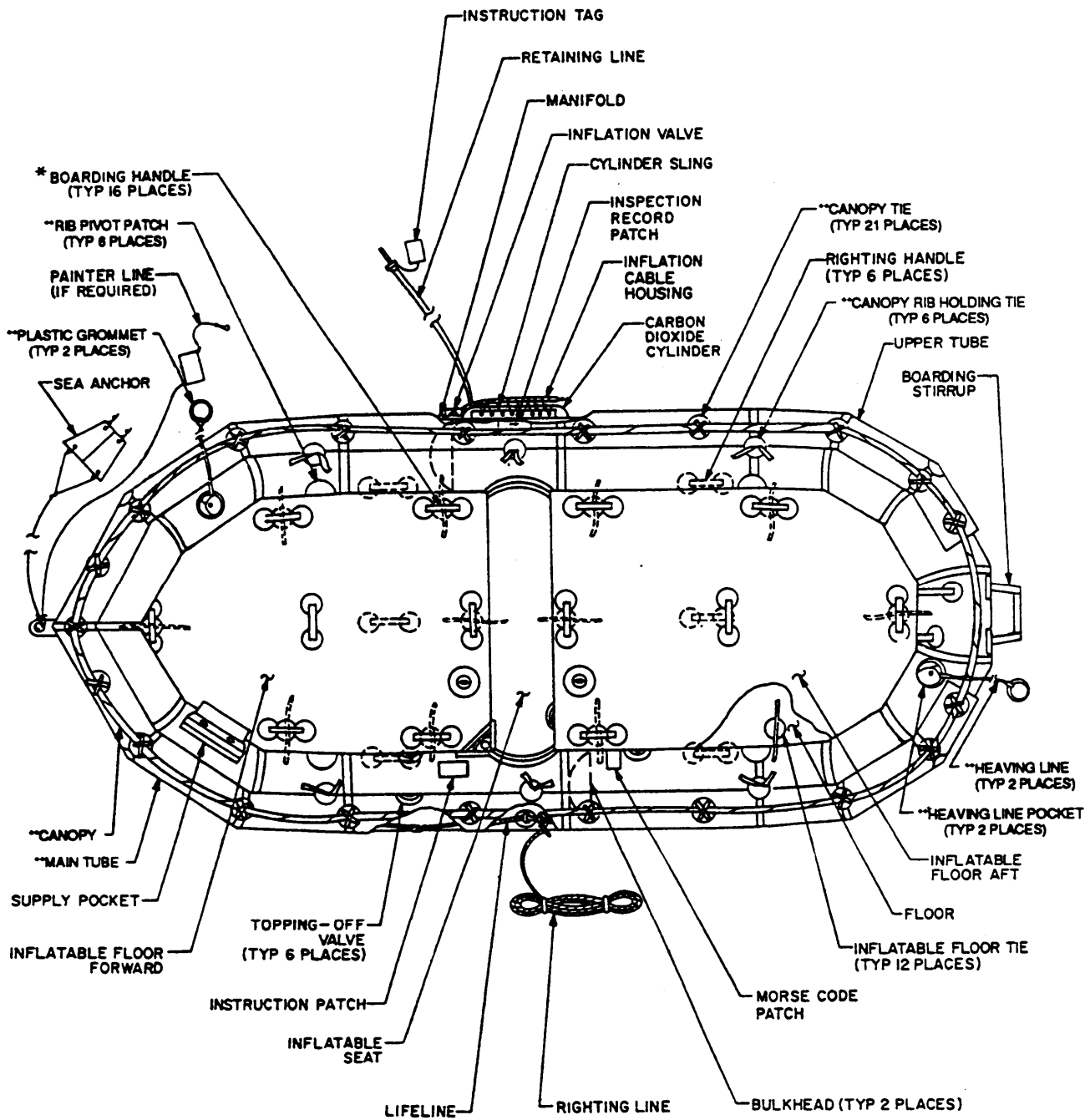

SECURING HANDLE (TYP 12 PLACES) LOCATED ON UNDERSIDE OF INFLATABLE FLOOR.

239.347.1

Figure 6-5.—LRU-14 series life raft assembly, parts nomenclature.

series life raft assembly parts nomenclature is shown in figure 6-5.

EQUIPMENT AND SURVIVAL ITEMS

CNO has established survival equipment lists as standards for all concerned. These lists provide

sufficient equipment and items for 24-hour survival.

The LRU-14 series life raft equipment, survival item requirements, and the applicable storage container are listed in table 6-5.

NOTE: To make up the package life raft assembly complete with accessories and survival items, all required components not supplied with the raft assembly must be individually requisitioned.

OPERATION

The LRU-14 series life raft assembly is inflated by pulling the inflation assembly actuating handle, located under the carrying case end flap. The inflation assembly inflates the main tube only. After the survivor boards the raft, the upper tube, seat, and floor sections should be inflated through the topping-off valves, with the hand pump provided in the accessory container.

The LRU-14 series life raft assembly can either be dropped to survivors or used by aircrewmembers in the event of an emergency. The raft is stowed either in a readily accessible area inside the aircraft

fuselage or in an aircraft compartment designed for rafts.

Prior to packing, the LRU-14 series life raft assembly should be updated with the modifications listed in NAVAIR 13-1-6.1.

The LRU-14 series life raft assembly maybe packed for droppable or aircraft installation. The method used depends upon aircraft application (fig. 6-6).

LRU-15/A LIFE RAFT ASSEMBLY

The LRU-15/A life raft assembly consists of an inflation assembly (carbon dioxide cylinder, inflation valve, and cover) and a 20-man life raft.

The life raft is made up of two single-compartment circular tubes connected by an equilizer tube; a noninflatable floor suspended

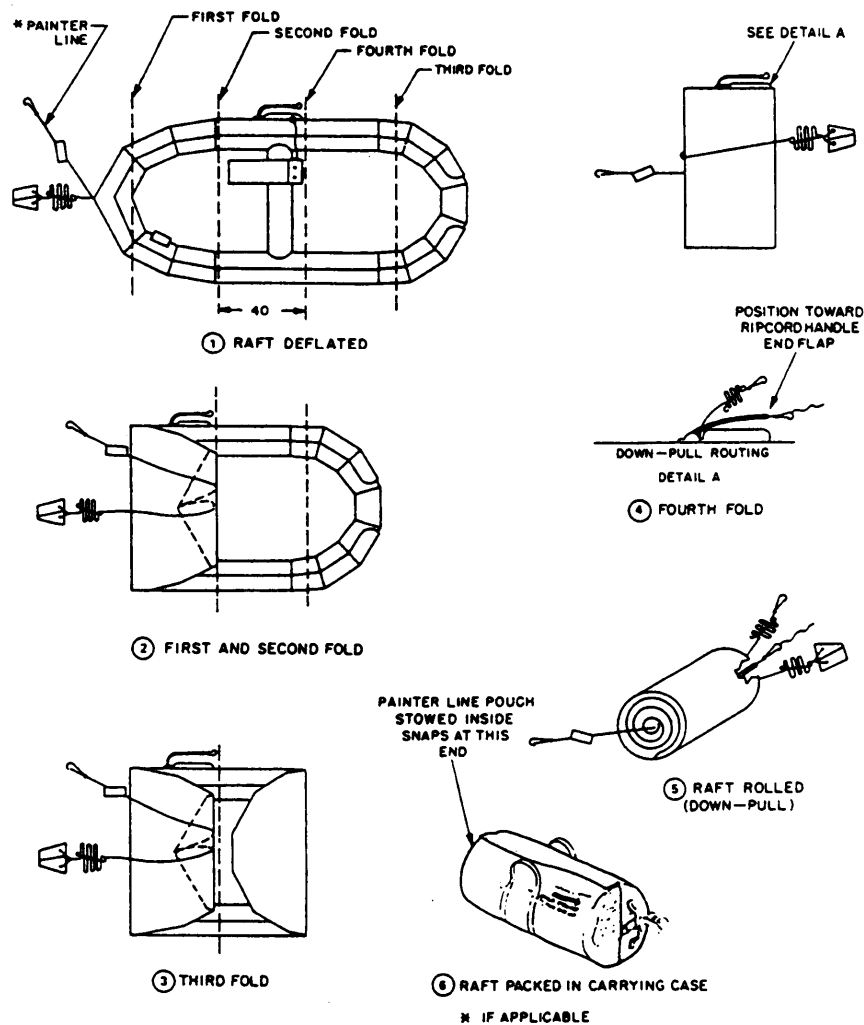

Figure 6-6.—LRU-14 series folding procedures (droppable).

between the circular tubes; and a boarding ramp permanently attached to each circular tube. The floor is equipped with a built-in inflatable floor support, and the inflatable boarding ramps are located on opposite sides of the raft.

A sea anchor, used to retard drifting, is stowed in the sea anchor pocket, which is located at the junction of the circular tubes. An inner lifeline, boarding handles, a heaving line, and emergency survival equipment, stowed in the accessory container, are provided for the safety and survival of the aircrewmembers. The inner lifeline, attached to the floor, and the boarding handles, attached to the circular tubes and boarding ramps, are used to secure the accessory container to the raft. Topping-off valves are located on each side of the tubes. A topping-off valve is also located on each side of the floor support. The LRU-15/A life raft assembly parts and nomenclature are shown in figure 6-7.

EQUIPMENT AND SURVIVAL ITEMS

The LRU-15/A life raft equipment and survival item requirements and the applicable storage container are listed in table 6-5.

The LRU-15/A life raft assembly (droppable) is inflated by pulling the inflation assembly handle, located under the carrying case end flap.

The LRU-15/A life raft assembly (wing installation) is automatically inflated and ejected from the raft compartment after the life raft compartment door has been released. A unique design feature of the LRU-15/A is that it is always right side up after inflation. The inflation assembly inflates the circular tubes and boarding ramps only. In the event that the inflation assembly does not function properly, the equalizer tube distributes gas equally between each circular tube. After boarding, the floor support is inflated with the hand pump provided in the accessory container. The circular tubes may be topped off, if necessary, from either side of the raft floor.

The LRU-15/A life raft assembly can be either dropped to survivors or used by aircrewmembers in the event of an emergency. Each type of packaged LRU-15/A life raft assembly is used in certain types of aircraft; for applicable configurations, refer to the aircraft MIM.

Prior to packing the LRU-15/A life raft assembly, it must be updated by comparing the configuration of the assembly with the modifications listed in NAVAIR 13-1-6.1.

EMERGENCY REPAIRS

Emergency repair of the LRU-15/A raft, when in the water, is accomplished by the use of the metal clamp type plugs provided in the accessory equipment container of each raft. No emergency repair equipment is provided with other types of rafts.

DEMONSTRATING THE USE OF RAFTS

Many ditching and water crashes occur in a rough sea or at night. Only complete familiarization with the use of survival equipment will give the aircrewman a chance of survival under such adverse conditions. Therefore, intensive drill in the use of rafts and their associated equipment is essential for safety.

The survival officer must be concerned with survival techniques and should see that a survival training program is set up in the parachute loft. In most cases, the chief in charge of the loft has the responsibility of setting up this training. As a PR2 you will have many occasions to participate in this training and, in many instances, may be completely responsible for the carrying out of the program. Regardless of who is in charge and must shoulder the complete responsibility, it is the duty of every PR to be completely familiar with all phases of survival training and to be able to demonstrate the use of survival equipment.

The multiplace egress trainer is a very effective system of training in water survival techniques. It is used to simulate an actual aircraft ditching, and to teach the best escape procedure with full equipment.

Although such complete courses of training cannot be conducted in certain localities because of the lack of specialized equipment, the PR should make every attempt to give aircrewmembers frequent practice in the actual use of the equipment. Discussions, demonstrations, and shop lectures are all helpful, but working with the actual raft equipment is the only way to acquire the knowledge essential to survival.

In demonstrating the raft's use, the most important thing to stress is that the retainer lanyard snap is firmly attached to the ring on the life vest before inflating the raft. Inflate the raft as soon as possible so that personnel can get out of the water. The raft is inflated by pulling on the short length cable attached to the CO₂ cylinder valve. After several hours, the CO₂ cylinder may be removed from the side of the raft. It tends to

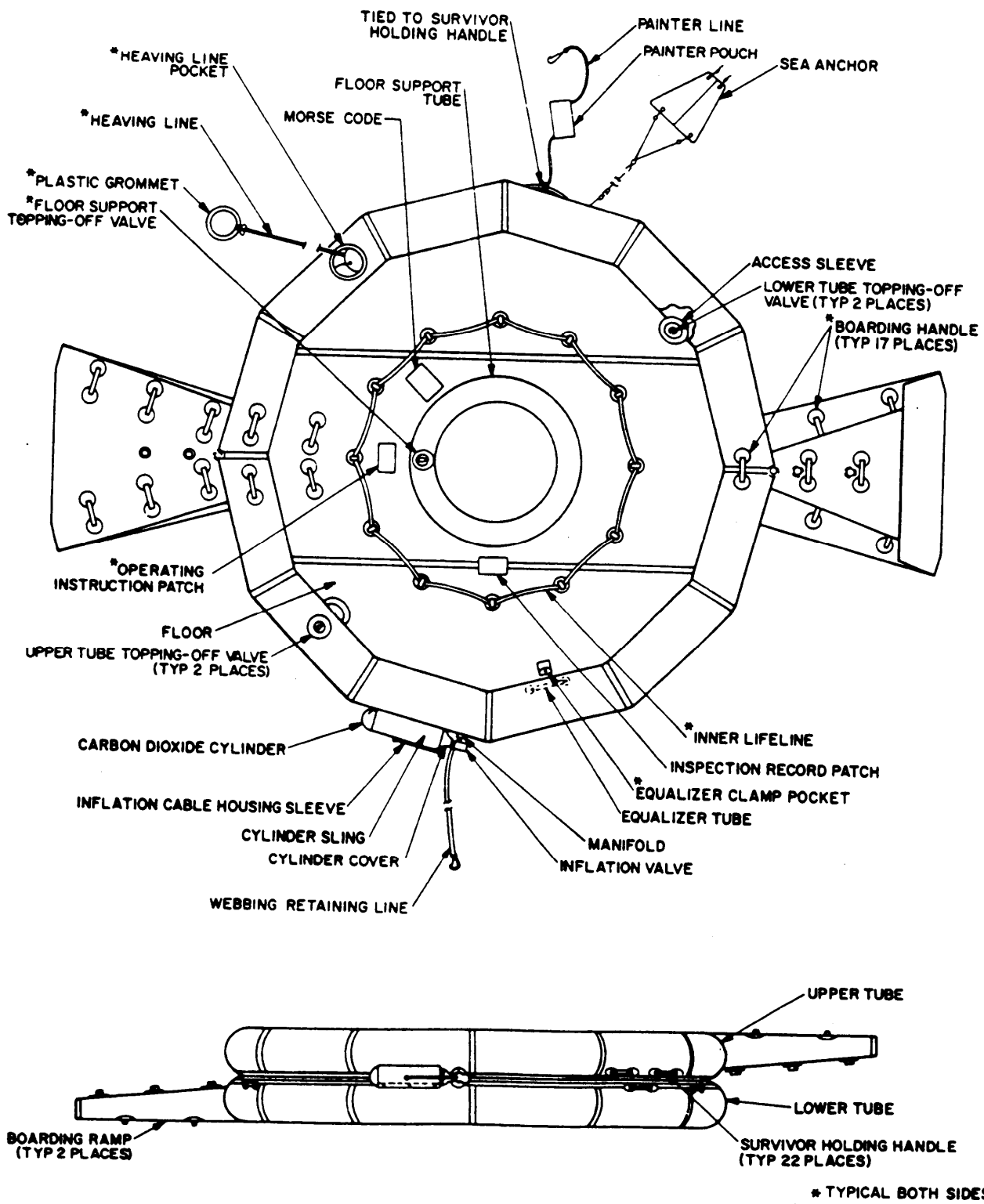

Figure 6-7.—LRU-15/A life raft assembly, parts nomenclature.

239.347

chafe the side of the compartment and acts as an anchor, causing the raft to orbit around it. Sometimes it is possible to back off the coupling between the cylinder and the manifold so that the cylinder releases from the mount. Once the cylinder has been removed, it is no longer useful in any way and should be thrown over the side. This, of course, is under actual emergency conditions; in a training demonstration, the cylinder should be saved and recharged for further use on the training equipment.

In demonstrating their use, also give instructions on manual inflation of rafts. If nothing happens after the CO₂ cable has been pulled, the carrying case should be pulled off and the raft unfolded so that the hand pump will be accessible. After the pump is removed, the first compartment to be inflated should be the seat. This will help keep the raft afloat so that the remaining compartment can be inflated with the pump. In attaching the pump, care must be taken not to screw the pump too tightly to the valve. If it is too tight, it may freeze and become impossible to loosen without some type of wrench or pliers.

BOARDING THE RAFT

The best method for boarding the multiplace life raft is to use the boarding stirrup located on the stem of the LRU-12/A, -13/A, and -14 series. This stirrup will allow the aircrewman to board the raft from the stern; boarding from the stern will lessen the possibility of capsizing the raft (fig. 6-8).

If the raft should capsize, it is best to approach it from the side on which the CO₂ cylinder is installed. The survivor reaches across the raft and grasps the righting handle farthest from the cylinder. Then, by sliding back into the water and pulling on the righting handle at the same time, the raft will turn right side up. By using this method, there will be no chance of the CO₂ cylinder hitting the survivor when he rights the raft (fig. 6-9).

Another important point to remember in righting the raft is to note the wind and take advantage of it. It is very hard to right a raft against the wind.

SAFETY PRECAUTIONS IN BOARDING RAFTS

Extreme care should be taken when boarding rafts or assisting personnel into the raft from the water. This is particularly so if these persons are wearing parachute harness or life vests. Once in

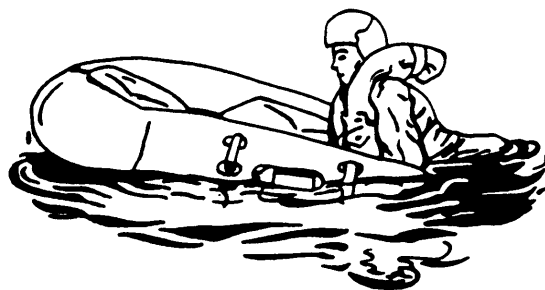

239.355

Figure 6-8.—Boarding the LR-1 raft.

the raft, all personnel should seat themselves on the floor and remain in that position if at all possible. Movement within the raft should be restricted as much as possible to keep friction at a minimum. All sharp objects should be collected and stored, especially jeweled rings, wristwatches, etc.

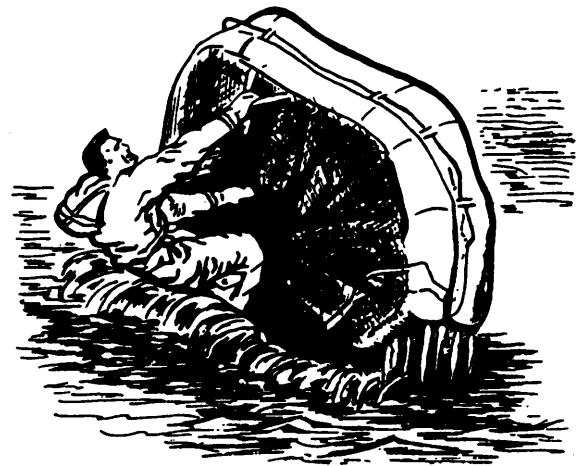

239.356

Figure 6-9.—Righting a capsized raft.

All loose articles of equipment should be properly packaged to protect the raft fabric.

ONE-MAN LIFE RAFTS

One-man life rafts are used with various soft and hard types of survival kits. They are intended for use by aircrew members forced down at sea. They can also be used when forced down over land for fording rivers and streams, or as a shelter.

LRU-7/P LIFE RAFT ASSEMBLY

The LRU-7/P consists of a simplified one-man life raft, a static line release mechanism, and a special container with tabs for attachment to the parachute and seat pan. Although simplified in its construction, the LRU-7/P is comparable to the standard Navy one-man life raft except it contains no survival items (fig. 6-10). The

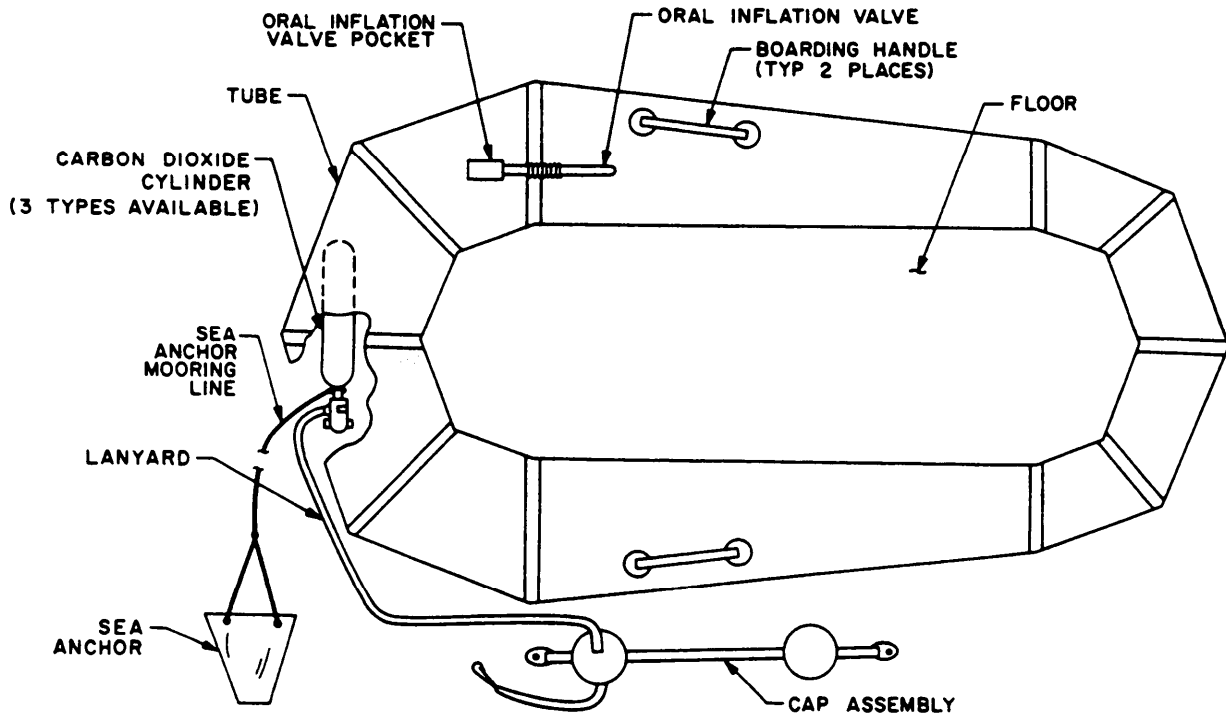

Figure 6-10.—LRU-7/P life raft assembly, parts nomenclature.

239.351.1

LRU-7/P is used with a modified SP-1A seat pan and NS-3 and NES-21A parachutes.

LR-1 LIFE RAFT ASSEMBLY

The LR-1 life raft assembly consists of an inflation assembly (carbon dioxide cylinder and inflation valve) and a one-man life raft; three types of carbon dioxide cylinders and three types of inflation valves are approved for service use.

The raft consists of a single-compartment flotation tube with a noninflatable floor. It is blue (when initially procured) and features a weathershield, sea anchor, sea anchor pocket, and a retaining line pocket. The weathershield is a dull sea-blue color on the outside and a bright red on the inside. In addition, a directive compliance patch and an inspection record patch are included for record keeping. The various applications of the LR-1 life raft are contained in NAVAIR 13-1-6.1.

Emergency survival equipment (when used) is secured to the raft by either a securing line or a drop line, as applicable. The packaged configuration of an LR-1 life raft assembly, including survival items, varies according to application.

To makeup a packaged assembly, the required components must be individually requisitioned, unless otherwise specified.

The LR-1 life raft assembly is inflated either manually by pulling the inflation assembly actuating lanyard, or automatically on the LR-1 (RSSK) by gravity drop on the kit actuation. The inflation assembly inflates the flotation tube. After boarding the raft, you can top off the LR-1 by using the oral inflation valve.

This section describes the components of the LR-1, the survival equipment, and the procedures for performing inspections and maintenance. We will not repeat procedures that parallel those already outlined for multiplace rafts.

Flotation Tube

The body of the raft consists of an encircling tube, which is one continuous chamber. There are no internal bulkheads as in the multiplace rafts. Various attachments to the flotation tube are shown in figure 6-11.

Oral Inflation Tube

The valve on the oral inflation tube closes automatically by spring pressure when it is not held open. The valve is locked shut by turning the

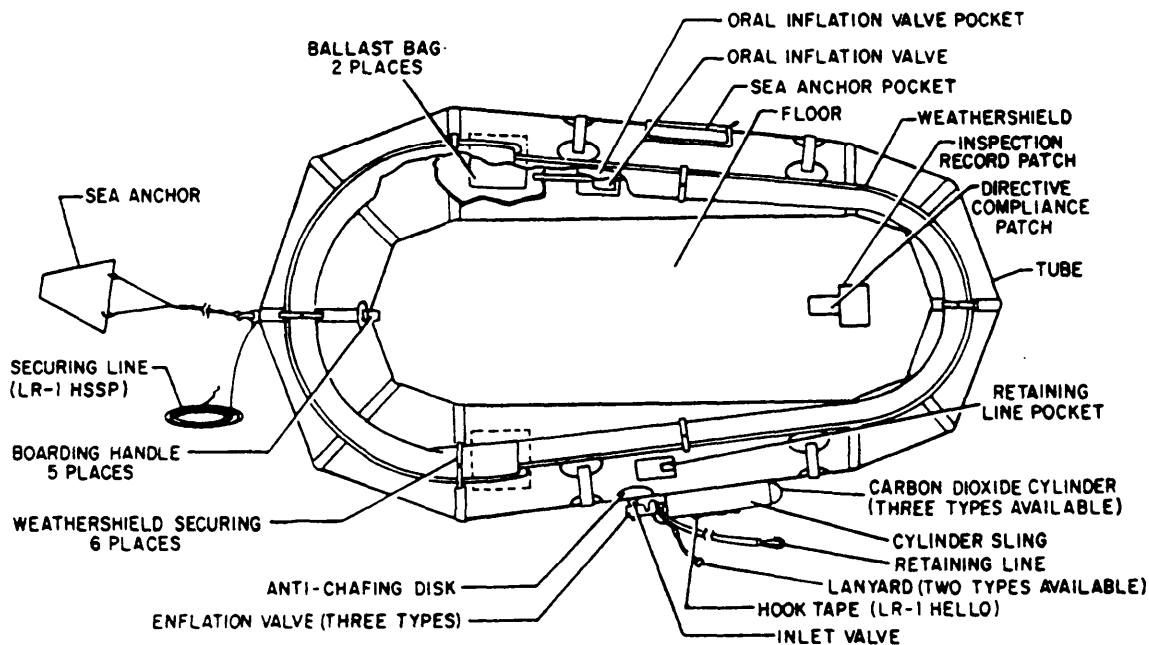

Figure 6-11.—LR-1 life raft assembly.

239.351

mouthpiece in a clockwise direction. The 3/8-inch oral inflation tube is cemented to the valve at one end, and at the other end, it has a molded flange that is cemented to the flotation tube.

Boarding Handles

Five handles are provided as aids for boarding the raft.

Ballast Bags

Ballast bags, installed at two locations, are required to increase the raft stability, to prevent the raft from becoming airborne during helicopter pickup, and to aid in boarding the raft.

Weathershield

The weathershield is used to protect the survivor from adverse weather.

Sea Anchor

The sea anchor is used to keep the inflated raft from drifting. The sea anchor is tied to the raft mooring line with type III nylon line, using a bowline knot; the other end is tied to the sea anchor mooring patch with a bowline knot. The bitter ends of both knots are seared and completed with an overhand knot to prevent them from untying. Before tying the knots, the ends of the nylon line are heat fused to prevent fraying.

Sea Anchor Pocket

The purpose of the sea anchor pocket is to prevent survivors from getting tangled up in the sea anchor line while boarding the raft. Downed aircrewmembers should remove the sea anchor from the pocket and cast the anchor adrift immediately after boarding the raft.

Securing Line

The securing line is 5 feet of nylon cord. It secures the raft to the raft container, to prevent loss of the survival items.

The nylon cord is inserted through the webbing loop on the sea anchor mooring patch and secured with a bowline knot, followed by an overhand knot. The free end is secured to the raft container during the raft packing.

Retaining Line

A nylon webbing retaining line 1 inch wide and 6 1/2 feet long is used to secure the raft to the user. One end of the retaining line is equipped with a snap hook. The other end is secured to the C O₂ cylinder neck by passing the end of the retaining line with the loop formed in it around the coupling nut between the raft and the inflation assembly. The end of the line containing the snap hook is then passed through the loop and pulled up tight.

Survival Items

The LR-1 packaged assemblies requiring survival items are equipped with the items listed in table 6-6. These items are packed in either the

Table 6-6.—LR-1 Life Raft Survival Items

DESCRIPTION	QUANTITY REQUIRED
Dye Marker	2
Distress Signal, MK-13 MOD 0 (2) or Distress Signal, MK-124 MOD 0	2
Emergency Radio Beacon AN/URT-33A	1
Battery Power Supply	1
Water, Drinking, Canned, Emergency (1)	1
Opener, Can, Hand	1
Cord, Nylon, Utility, 50 feet	1
SRU-31/P Individual Survival Kit (Part 1 - Medical, Part 2 - General)	1
Ground Air Emergency Code Manual	1
Combat Casualty Blanket Type II, 3 oz.	1
Bailing Sponge	1
Personnel Lowering Device (1)	1
NOTES: 1. Optional item. 2. The MK-13 shall be used until depleted. The MK-124 will replace the MK-13 as stock becomes available.	

combination carrying case and equipment container or in the equipment container, as applicable. The remaining space in the container may be used for any specialized equipment for specific environmental or geographic conditions, as directed by the area commander.

You should refer to NAVAIR 13-1-6.1 for information concerning which type of packaged LR-1 life raft assembly is used aboard certain types of aircraft.

Inspection

During the life raft inspection phase and prior to starting any packing procedures, the life raft must be updated and modifications incorporated if required. Compare the life raft assembly configuration with the applicable raft modifications listed in NAVAIR 13-1-6.1.

All life raft assemblies get a calendar inspection upon issue and at intervals that coincide with the aircraft inspection cycle. However, the interval between calendar inspections must not exceed 231 days.

The procedure for inspecting and testing the life raft is generally the same as those given earlier in this chapter for the multiplace life raft. Additionally, you should read NAVAIR 13-1-6.1. Where there are considerable differences in raft construction, certain steps may be eliminated or added as necessary. For example, life rafts are not constructed with internal bulkheads. Since there is only one continuous flotation tube, the internal bulkhead test is not necessary on the life raft. The life raft is fitted with an oral inflation tube, but it serves the same purpose as the multiplace raft topping-off valves. Therefore, the same general considerations given the topping-off valve should be applied to the oral inflation tube. For instance, although the exposed end of the oral inflation tube has no rough edges, it is kept in a supporting pocket.

LIFE PRESERVERS

Life preservers are worn by aircrew members on overwater flights. Their function is to keep them afloat until a raft can be reached or until a rescue team arrives. Proper inspection, maintenance, and handling of life preservers are necessary to prevent any possible malfunction that could result in the loss of life.

LPU-21/P SERIES LIFE PRESERVER ASSEMBLY

The LPU-21/P series life preserver assembly is authorized for use by all aircrew personnel wearing compatible flight clothing. It is designed as a constant wear item for use with the survival vest and will not interfere with the removal of the nonintegrated parachute harness. Survival item pouches are attached to the life preserver casing. The dye marker and signal flares that go into these pouches are not initially supplied and must be individually requisitioned. Modifications to the LPU-21/P life preserver have resulted in a new letter designation being assigned to the preserver. For the sake of clarity, the term LPU-21/P series is used where appropriate.

WARNING

THE LPU-21/P SERIES LIFE PRESERVER ASSEMBLIES ARE NOT USED IN EJECTION SEAT AIRCRAFT.

NOTE: The LPU-21B/P and LPU-21C/P life preserver assemblies must NOT be configured with the FLU-8A/P automatic inflation device.

The LPU-21/P and LPU-21A/P life preserver assemblies use pull toggles for activation. After the incorporation of Aircrew System Change 405, which directs installation of beaded inflation handles, the LPU-21/P and LPU-21A/P were updated to become the LPU-21B/P. The beaded inflation handles improve toggle accessibility and provide the inflation system with a multi-directional pull capability.

The LPU-21/P series life preserver assembly weighs 4 pounds (without survival items) and provides a minimum of 65 pounds of buoyancy. The flotation assembly is constructed of polychloroprene-coated nylon cloth and consists of two independent flotation chambers. One chamber consists of the left waist lobe joined by a tube to the right collar lobe. This chamber is serviced by the carbon dioxide inflation assembly and oral inflation valve attached to the left waist lobe. The other chamber consists of the right waist lobe joined by a tube to the left collar lobe. This chamber is serviced by the carbon dioxide inflation assembly and oral inflation valve attached to the right waist lobe. The two chambers are sewn together at the collar lobes (fig. 6-12).

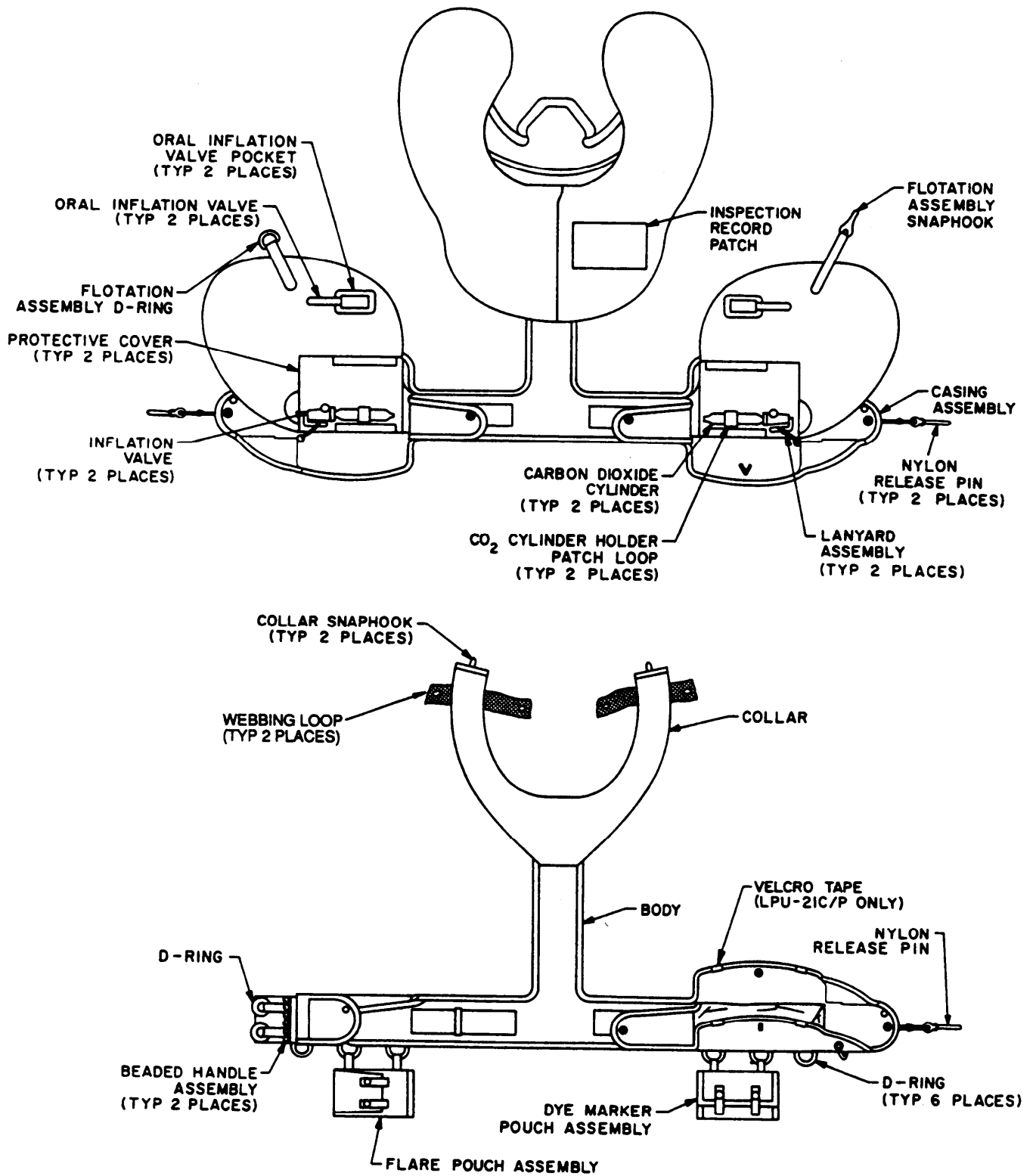

Figure 6-12.—LPU-21/P series life preserver assembly, parts nomenclature.

239.468

Each waist lobe of the flotation assembly is equipped with an attachment patch used for securing the casing assembly by means of rivets. In addition, the right waist lobe is equipped with one snap hook and the left waist lobe is equipped with one D-ring. The snap hook and the D-ring are used to secure the waist lobes together after inflation. Survival item pouches are fastened to the life preserver D-rings with directional snap fasteners.

Each collar lobe of the flotation assembly is equipped with a snap hook for attachment to the survival vest D-rings (parachute risers are routed outside of the collar lobes). In addition, an inspection record patch is also provided on a collar lobe.

The casing assembly is constructed of fire-retardant Aramid cloth and protects the flotation assembly. The casing assembly also provides for size adjustment and attachment to the wearer. The casing assembly consists of the adjustable casing, an adjustable webbing belt, belt keepers and D-rings, and the front connector assembly.

The webbing belt, attached to the inside waist portion of the casing assembly, provides for waist size adjustment from 30 to 44 inches. The webbing belt keeper loops retain the webbing belt and provide for attachment of the survival vest about the wearer's waist. In addition, there are six D-rings secured to the webbing belt keeper loops, used for attaching the survival item pouches, a raft retaining line, and other accessories.

Hook and pile tapes, attached to the outside waist portion of the casing, are used for slack adjustment. In addition, hook and pile tapes, attached about the circumference of the collar casing and the lower edge of the back portion of the casing, are used to enclose the casing assembly about the flotation lobes.

The casing assembly is secured around the wearer's waist by the front connector assembly, which consists of two snap hooks and two D-rings backed by webbing pads for comfort.

Each inflation assembly is made up of a carbon dioxide cylinder and an inflation valve. The inflation assemblies are connected to valve stems attached to each waist lobe (each valve stem is equipped with a check valve to prevent leakage).

As stated earlier, the LPU-21/P series life preserver assembly is authorized for use by all aircrew personnel wearing compatible flight clothing. LPU-21/P series life preservers that are modified to incorporate the FLU-8/P series automatic inflation device will be used in ejection seat type of aircraft only. LPU-21/P series life

preservers modified with the FLU-8A/P inflator will be redesignated the LPU-23A/P life preserver.

The LPU-21/P series is manually inflated by pulling both inflation assembly beaded handles in a natural, slightly down and straight out position from the body. This action removes the retaining pins securing the casing assembly about the waist lobes and actuates the inflation assemblies. The hook and pile tapes securing the casing assembly about the collar lobes will separate as the preserver inflates.

NOTE: The casing must be manually opened and the flotation assembly unfolded prior to inflating a preserver through the oral inflation valve.

In an emergency situation, the oral inflation valves may be used to top off an inflated preserver, maintain inflation of a leaky preserver, or inflate a chamber if an inflation assembly malfunctions. The oral inflation valves are also used to inflate a preserver with air during an inspection test and to evacuate a preserver in preparation for packing.

LPU-23/P SERIES LIFE PRESERVER ASSEMBLY

The LPU-23/P series life preserver assemblies contain an automatic inflator that is intended for use by an aircrew member in an ejection seat aircraft ONLY.

The LPU-23/P assembly is identical to the LPU-21/P assembly except for the FLU-8A/P automatic inflation device (fig. 6-13).

The LPU-23/P series life preserver assembly is inflated either automatically (by immersion in fresh or salt water) or manually (by pulling both inflation assembly beaded handles).

NOTE: The primary means of inflation is to manually pull the beaded handles.

Automatic inflation occurs when immersion in water triggers the electronic circuit, firing the explosive primer. The high-pressure primer forces the piecing pin forward, releasing the inner end of the packing cord loop and puncturing the 35-gram CO₂ cylinder, which releases the pressurized gas. Automatic inflation is a onetime function of the FLU-8A/P inflator. A new inflator must be installed to replace the previously spent device. Manual inflation occurs when both

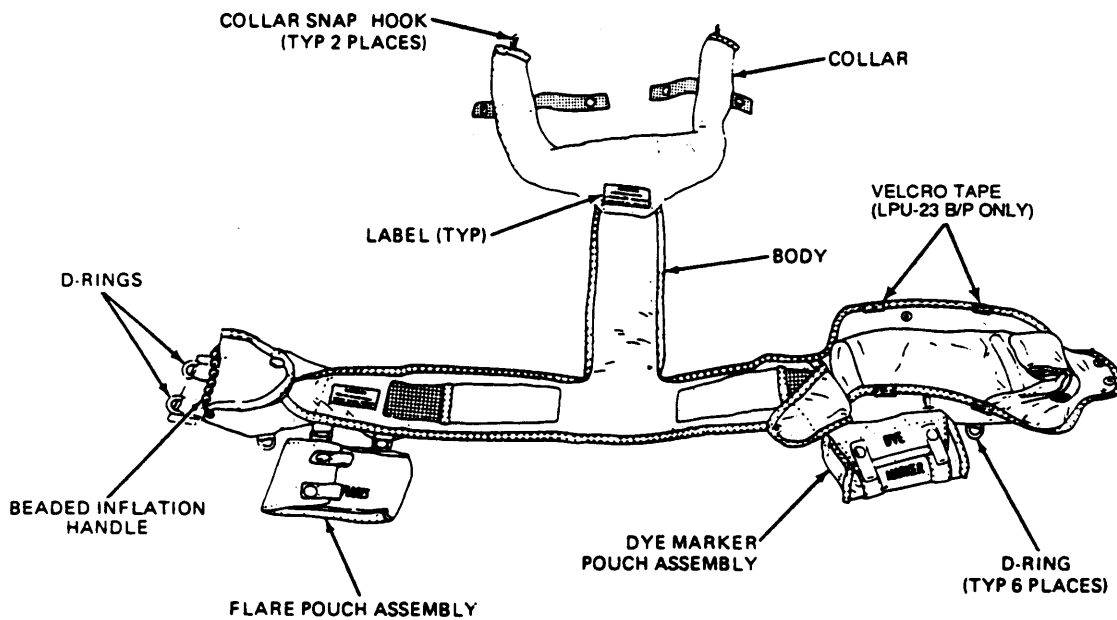
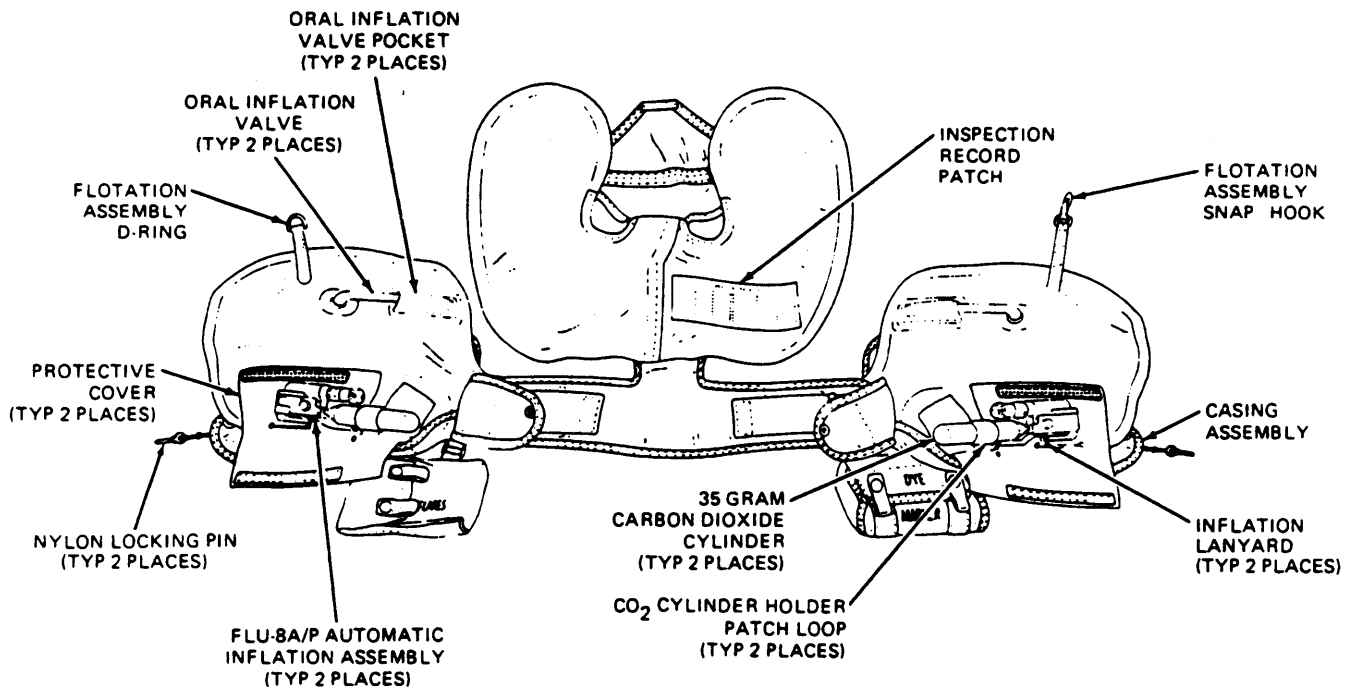

Figure 6-13.—LPU-23/P series life preserver assembly, parts nomenclature.

beaded inflation handles are pulled in a natural, slightly down and straight out position from the body. The FLU-8A/P inflator may be operated manually an unlimited number of times without affecting the onetime automatic feature.

LPU-24/P SERIES LIFE PRESERVER ASSEMBLY

The LPU-24/P life preserver assembly is identical to the LPU-23/P life preserver assembly except for the fabrication of the casing assembly. The LPU-24/P has a casing assembly that is constructed from rubber-coated nylon cloth instead of Aramid, fire-resistant fabric like the LPU-21/P and the LPU-23/P series life preservers. The LPU-24/P life preserver is not covered in this chapter.

LPP-1/1A LIFE PRESERVER ASSEMBLY

The LPP-1/1A life preserver assembly is authorized for use by passengers in cargo or transport type of aircraft for sea survival situations.

WARNING

THE LPP-1/1A LIFE PRESERVER IS NOT SUITABLE FOR USE BY SMALL CHILDREN IN NAVAL AIRCRAFT.

The LPP-1 and LPP-1A life preserver assemblies are identical with the exception of the mechanical inflation assembly.

The LPP-1/1A life preserver assembly (fig. 6-14) weighs approximately 3 pounds and provides a minimum of 29 pounds of buoyancy. The LPP-1/1A life preserver assembly consists of a single-compartment yoke-type flotation assembly, a pouch and belt assembly, an inflation assembly, and a storage container. Survival items are also provided. To make up the LPP-1/1A life preserver assembly, all required components not supplied with the preserver must be individually requisitioned.

The flotation assembly is constructed of chloroprene-coated nylon cloth. It is equipped with an oral inflation valve, a valve stem, survivor locator light attachments, a whistle pocket, a belt loop, and an inspection record patch (fig. 6-14).

The pouch and belt assembly consists of a rubber-coated nylon cloth pouch and an adjustable belt. The pouch contains the flotation assembly and survival items. The belt consists of a 53-inch piece of webbing, an adjustable buckle and clasp, a toggle assembly, and a toggle assembly pocket. The belt adjusts from a waist size of 30 to 52 inches and attaches the flotation assembly and pouch to the wearer by means of the belt loop on the flotation assembly and the slots in the back of the pouch. The toggle assembly consists of a wooden toggle and line, and is used to secure survivors together while they are in the water. When not in use, the toggle line is wrapped around the wooden toggle and stowed in a pocket located on the belt (fig. 6-14).

NOTE: The carbon dioxide cylinder is NOT supplied with the preserver assembly and must be requisitioned separately.

The LPP-1 inflation assembly consists of a Type I (MIL-C-25369), 25- to 28-gram carbon dioxide cylinder and an inflation valve. The LPP-1A inflation assembly consists of a Type II (MIL-C-25369), 28- to 31-gram carbon dioxide cylinder and an inflation valve (MIL-I-23145). The inflation assembly is connected to the valve stem on the front of the flotation assembly. The valve stem is equipped with a check valve, which prevents leakage.

The storage container is used to store the life preserver assembly when it is not in use. The storage container also has donning instructions printed on it.

As LPP-1/1A life preservers become available, the use of all other life preservers by personnel authorized to use the LPP-1/1A will be discontinued. Passengers whose total clothing and equipment weight does not exceed 15 pounds and who are not carrying any high density items like weapons or other similar metallic items are authorized to continue use of MK-2 life preserver, with attritional basis method for replacement with LPP-1/1A.

LPU-30/P LIFE PRESERVER ASSEMBLY

The LPU-30/P life preserver assembly is a vest-type preserver (cardigan style, sleeveless) that weighs approximately 3 pounds (without survival items) and provides a minimum of 29 pounds of buoyancy. The preserver consists of a single-compartment flotation assembly, a fully lined

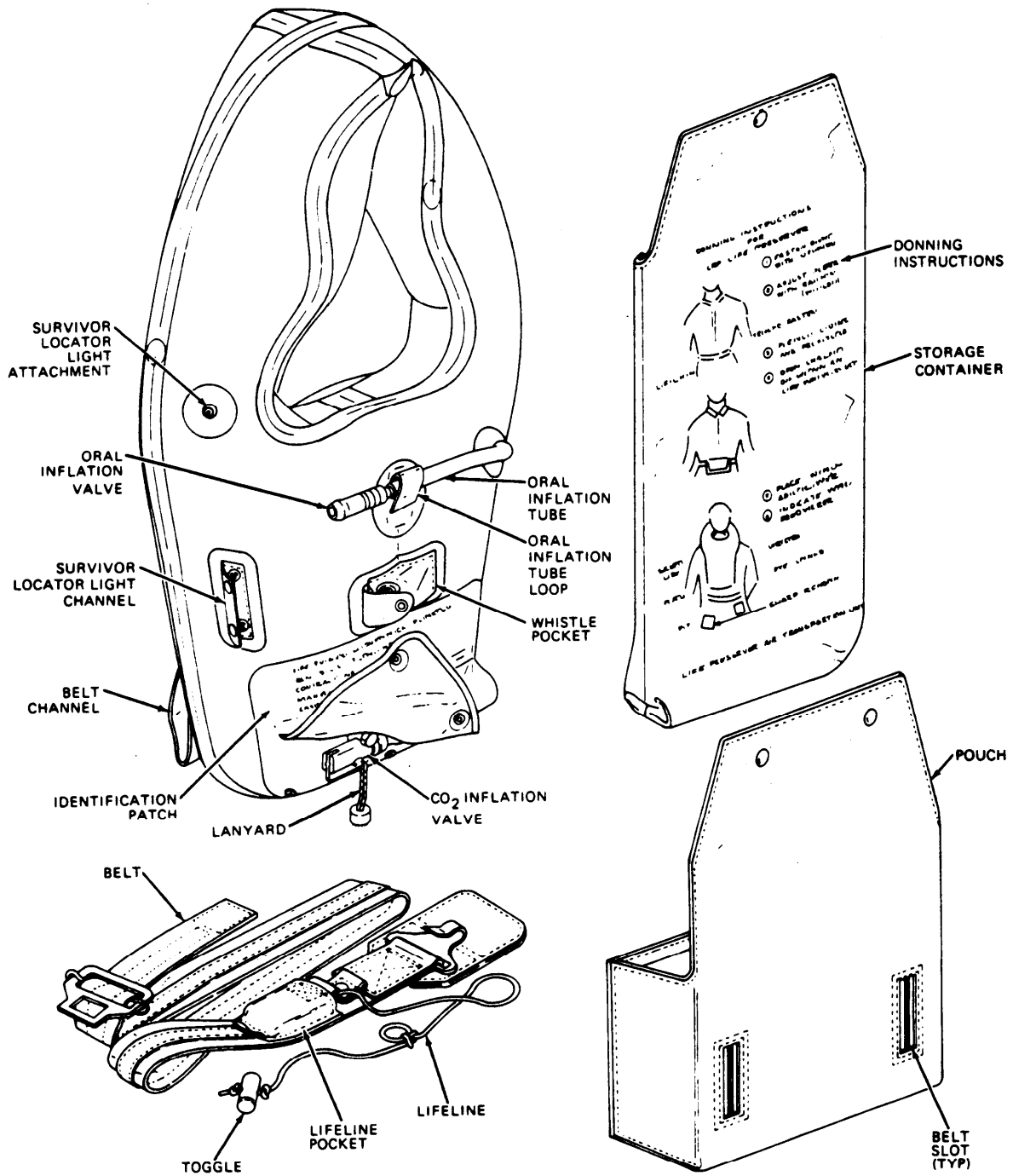

Figure 6-14.—LPP-1/A life preserver assembly.

protective cover with nondirectional front closure snaps, side buckle adjustments, and inflation assembly. Survival items are also provided. To make up the LPU-30/P life preserver assembly, all required components and survival items must be individually requisitioned (fig. 6-15).

The flotation assembly is constructed of polyurethane-coated nylon cloth and is available in one size. It is equipped with an oral inflation valve and tube, a pressure relief valve to prevent over inflation, a brass manifold for attachment of the inflator, a 1-inch piece of hook tape secured to the left front portion of the bladder, and an antichafing pad sewn to the inside neck area on the bladder.

The protective cover is fabricated of white cotton balloon cloth (MIL-C-332) and is available in medium (chest up to 48 inches, & 1/2 inch) and large (chest up to 53 inches, ± 1/2 inch). The cover has nondirectional front closure snaps and side buckle waist adjustments and is fully lined. There is also a strip of reflective tape sewn across each shoulder and a strobe light pouch, which must be sewn to the upper breast portion of the protective cover, and a sea dye marker pouch, which must be sewn to the lower left portion of the protective cover.

The inflation assembly consists of two Type II (MIL-C-601), 12-gram CO₂ cylinders and a Type III (MIL-I-23145) inflation valve. The inflation assembly is connected to the valve stem located on the right front of the flotation assembly. The valve stem is equipped with a check valve to prevent leakage.

The LPU-30/P is manually inflated by pulling the inflation assembly lanyard down. In an emergency situation, the oral inflation valve is used to top off an inflated preserver, maintain inflation of a leaky preserver, or inflate a preserver when the inflation assembly malfunctions or fails. The oral inflation valve is also used to inflate a preserver with air during an inspection test and to deflate a preserver in preparation for issue.

The LPU-30/P life preserver is used by passengers in all helicopters and in the C-1, C-2, and US-3A type aircraft. The LPU-30/P must not be confused with the MK-1 flight deck life preserver. Information on the MK-1 preserver can be obtained by contacting Naval Sea Support Center Pacific, P.O. Box 85548, San Diego, CA 92138-5548, ATTN: Code 914. Request MIP H-402/2-47.

LIFE PRESERVER INSPECTIONS

All life preservers need to have preflight, special, and calendar/phase inspections.

The preflight inspection is performed before each flight by the aircrewman to whom the life preserver is assigned. A preflight inspection is also performed by assigned aircrewmen on life preservers installed in aircraft.

The special inspection is done on all aircraft-installed life preservers at intervals not to exceed 30 days. The inspection is performed at the organizational level of maintenance by personnel assigned to the aviator's equipment branch.

When the special inspection is completed and the life preserver is found satisfactory, the inspection date and inspector's signature are written in the inspection section of the Aviation Crew Systems History Card. The 30-day special inspection may be recorded on a separate history card from the history card recording calendar/phase inspections, functional checks, and modifications.

NOTE: The calendar inspection interval for LPA type and LPU-21/P series preservers assigned to VP squadron selected air reserve aircrewmen has been extended to 180 days from 90 days, providing the preservers are stowed under controlled conditions.

The calendar/phase inspection must be performed on all life preservers prior to placing them in service. After that, the inspection cycle is as follows: personal issue life preservers are inspected once every 90 days. Aircraft-installed life preserver inspection should coincide with the inspection cycle of the aircraft in which installed. In no case should the interval exceed 231 days. Unless operational requirements demand otherwise, the life preserver calendar/phase inspection is performed by the intermediate level of maintenance or above. As part of inspecting the preserver, the functional test is performed prior to placing it in service, every fourth inspection cycle thereafter, and whenever an inflation assembly is replaced. Also, the leakage test is performed during every inspection cycle. A battery visual inspection for the LPU-23/P series and LPU-24/P series will be performed prior to placing life preservers in service, and every fourth inspection cycle thereafter.

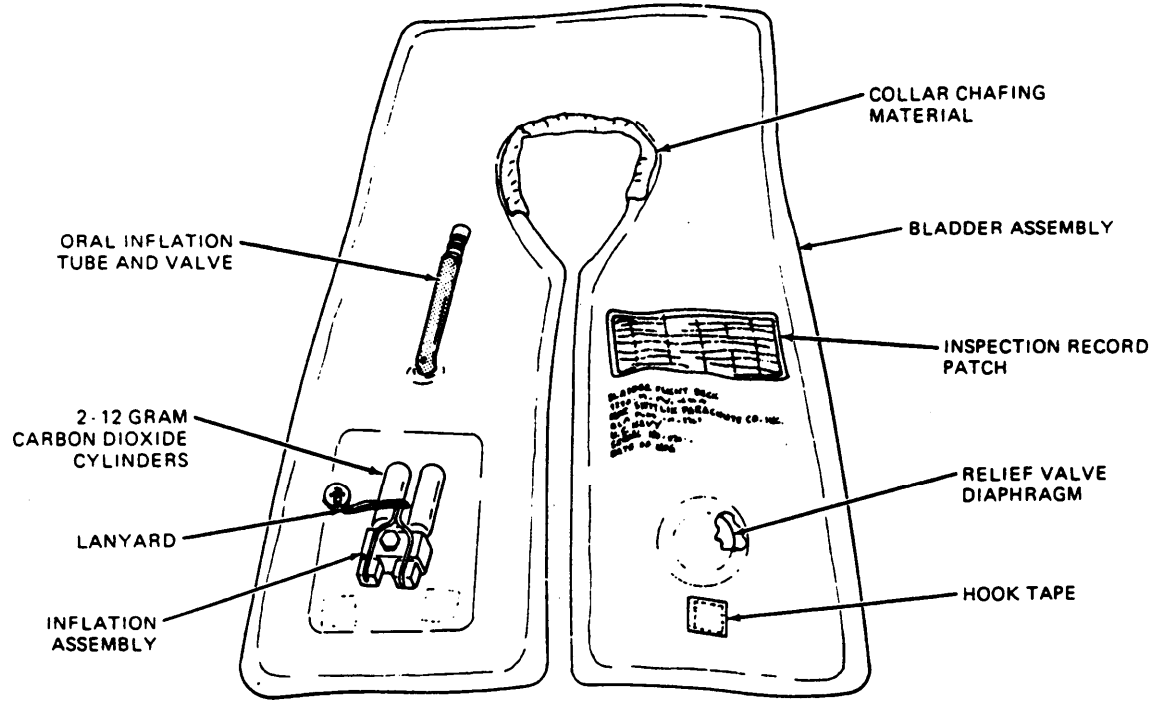
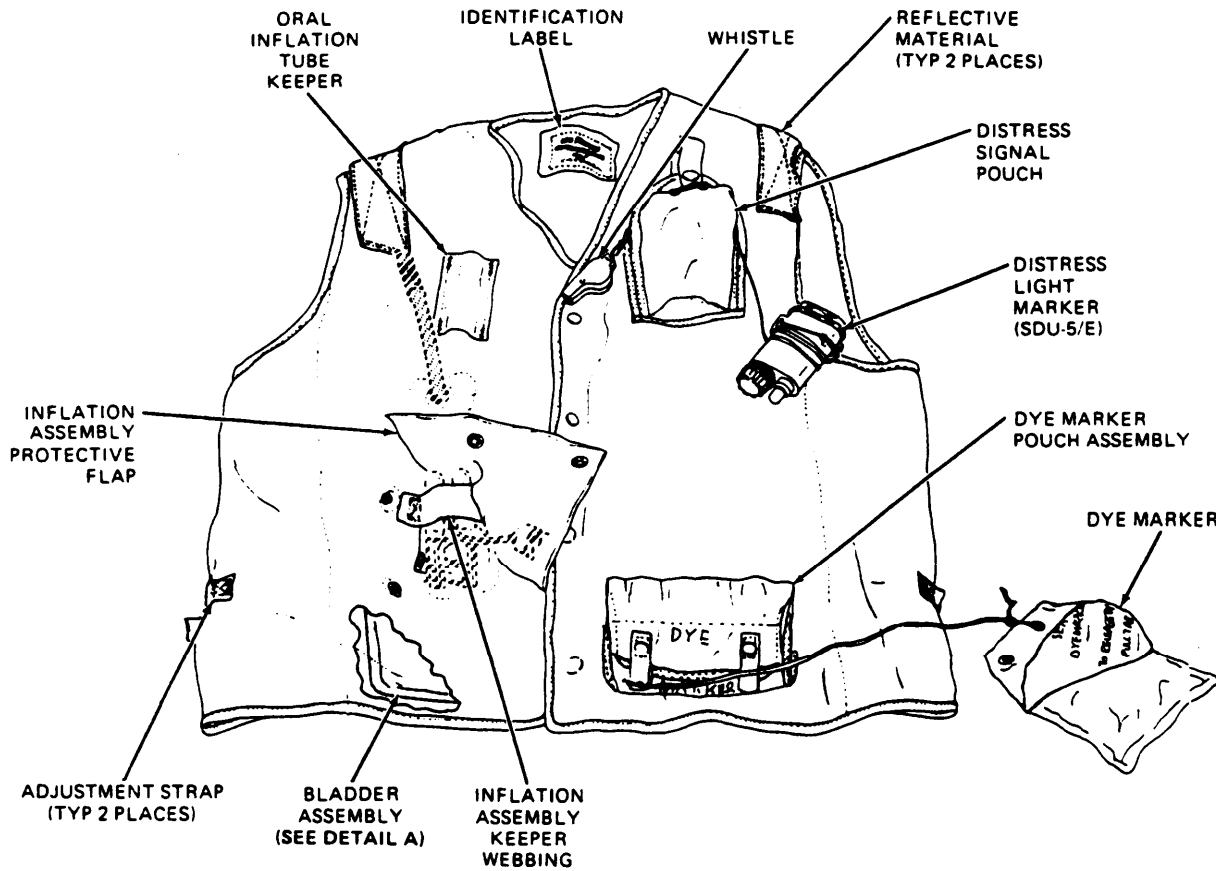

DETAIL A (BLADDER ASSEMBLY REMOVED)

Figure 6-15.—LPU-30/P life preserver assembly, parts nomenclature.

FUNCTIONAL TESTING

Before you attempt to perform a functional test, you should ensure that the work area surrounding the preserver is free of all foreign objects. This is done to prevent any accidental damage to the life preserver. When you perform a functional check, you want to ensure that the system operates as if the aircrew member were using it in an emergency. Therefore, your first step is to pull the actuation toggle.

The preserver should fully inflate to its design shape without any evidence of restriction in less than 30 seconds. If the preserver does not meet this requirement, you will have to determine the reason and correct it. To do this, first look at your stem and valve. Sometimes dirt or foreign matter can cause a slow inflation. If you make any corrections, the preserver is functionally tested again.

Deflate the preserver by using a vacuum pump and a 3/8- or 1/2-inch inside diameter rubber hose. Attach one end of the rubber hose to the vacuum pump, and the other end will go to the oral inflation valve or to the carbon dioxide cylinder valve, depending on which type you are using. After the preserver has been completely deflated, release the oral inflation valve or put the CO₂ cylinder back into the valve.

The functional check is only performed when the preserver is placed into service and every fourth calendar check after that.

LEAKAGE TEST

All life preservers are subjected to a leakage test each calendar/phase inspection. This test is performed each time the preserver comes into be checked, even when a functional test is required. A special test fixture is needed to perform this test.

Test Fixture

A suggested test fixture, consisting of a three-way valve, pressure gauge, and adapters for compartments being tested, is shown in figure 6-16. The fixture must be fabricated to meet the requirements of the schematic shown in figure 6-17.

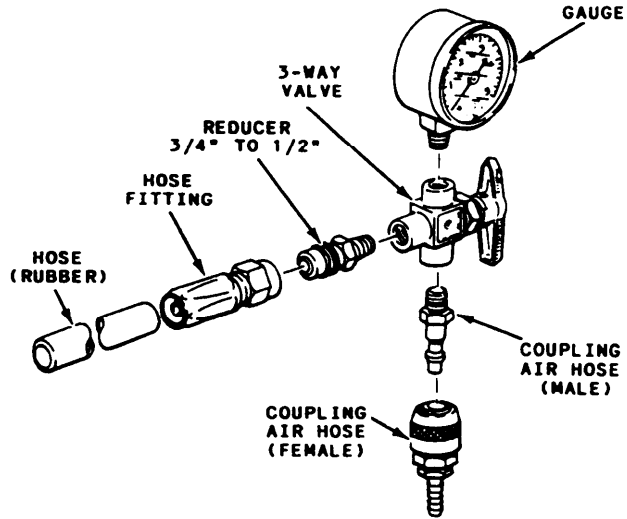

239.471

Figure 6-16.—Leakage test fixture life preserver.

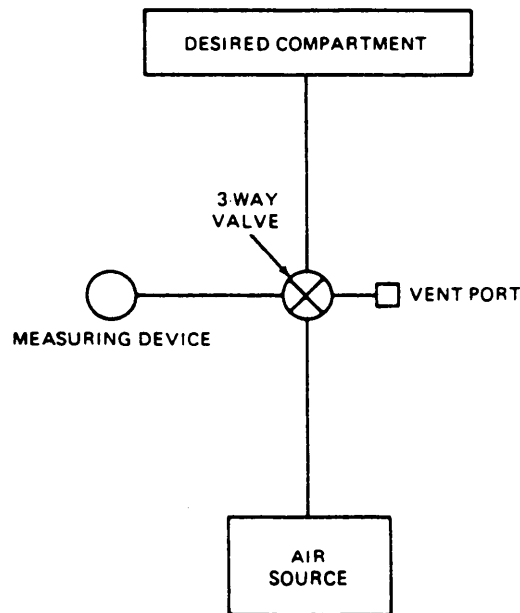

Figure 6-17.—Test rig schematic.

Test Procedure

To test life preservers, proceed as follows:

1. Ensure all carbon dioxide has been removed from any preserver that has been functionally tested.
2. To test the LPU-28/P life preserver, insert a 3/4-inch O.D. rubber hose into the oral inflation

Table 6-7.—Life Preserver Test Pressures

PRESERVER TYPE	FLOTATION CHAMBER TEST SEQUENCE	LEAKAGE TEST PRESSURE (PSIG)	MINIMUM PRESSURE (PSIG)
LPA-2 series	Both Chambers Simultaneously	2.0	1.6
LPU-21/P series	Both Chambers Simultaneously	2.0	1.6
LPU-23/P series	Both Chambers Simultaneously	2.0	1.6
LPU-24/P series	Both Chambers Simultaneously	2.0	1.6
LPU-28/P	Single Chamber Preserver	2.0	1.6
LPU-30/P	Single Chamber Preserver	1.0	0.8
LPP, Pouch Type	Single Chamber Preserver	2.0	1.6

hose mouthpiece. Maintain pressure between the rubber hose and the oral inflation hose mouthpiece to ensure a good seal. Depress the valve on the oral inflation hose and alternately position the leakage test fixture valve between the measuring device, vent, and air supply until the overpressure relief valve opens (2.5 psig ± .5 psig). Rotate the leakage test fixture valve to the measuring device position to ensure that the life preserver is inflated to the proper pressure. Release the valve on the oral inflation hose. Inspect for proper operation of the relief valve.

3. To test all preserver chambers, except LPU-28/P, unlock the oral inflation valve and insert it into the rubber hose. Rotate the valve to the air supply position and inflate the chamber. Alternately position the valve between the measuring device, vent, and the air supply until the proper pressure is attained.

4. Turn off the air supply, and after a minimum of 15 minutes, readjust the pressure, if necessary, to the original pressure. Refer to table 6-7.

5. Disconnect the air supply and check test fixture for leaks. Ensure all valves are closed.

6. Record temperature and barometric pressure.

7. Four hours after the adjustment period in step 4, record the test pressure.

8. Record temperature and barometric pressure and correct test pressure for any changes in temperature and barometric pressure. Figure 6-18 is an example of how you would record this information.

EXAMPLE

UNCORRECTED TEST READING 1.70 PSI

	TEMP.	BARO.
START	75°F	29.90 IN. Hg
END	70°F	29.70 IN. Hg
DIFFERENCE	-5°F	-.20
CORRECTION	+.155	-.098

TEMP. CORRECTION	+ .155
+ BARO. CORRECTION	- .098
CORRECTION	+ .057
UNCORRECTED READING	1.700 PSI
+ CORRECTION	+ .057
CORRECTED READING	1.757 PSI

Figure 6-18.—Example for recording readings.

CAUTION

DO NOT SUBMERGE LPU-23/P SERIES AND LPU-24/P SERIES LIFE PRESERVERS IN WATER TO CHECK FOR LEAKS.

After 4 hours, if the pressure of the chamber is below 1.60 psig, inflate to leakage test pressure and coat with a soap solution to locate any leaks. Mark any leak area you find. Rinse the preserver with fresh water, air dry it, and repair it in accordance with NAVAIR 13-1-6.1.

If the preserver has held the required pressure, deflate it. Ensure that the inflation valve lever is cocked. Install a carbon dioxide cylinder.

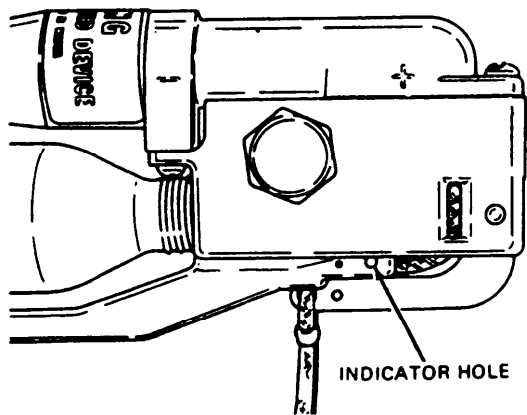

239.472

Figure 6-19.—Checking for silver indicator.

This completes the testing for leaks within the flotation assembly. To complete the calendar inspection, you will have to inspect the remaining components of the life preserver.

VISUAL INSPECTION

The visual inspection is performed along with each calendar inspection, at which time it is performed before you perform the leakage test. To perform a visual inspection, inflate the preserver to 1 psi and look it over real good. Look for any fabric cuts, tears, deterioration, or abrasion. Any of these defects can cause leakage. Check the valve stem for security and ensure that the silver indicator is not visible in the firing check port (indicator hole) (LPU-23/P and LPU-24/P). See figure 6-19. If the silver indicator is visible, the inflator is spent and the automatic feature of the inflator is negated. A new inflator should be installed on the life preserver to replace the previously spent inflator. Refer to NAVAIR 13-1-6.1.

LPU-23/P and LPU-24/P series preservers use the FLU-8A/P automatic inflator. The service life of each FLU-8A/P series automatic inflator is 66 months from the date of manufacture. If service life expires prior to the next scheduled calendar inspection, replace the inflator. Refer to NAVAIR 11-100-1, *Cartridges and Cartridge Actuated Devices for Aircraft and Associated Equipment*. Also refer to NAVAIR 13-1-6.2, section 2-5, *Cartridges and Cartridge-Actuated Devices (General Safety Instructions)*.

Battery Visual Inspection, LPU-23/P (Series) and LPU-24/P (Series)

To inspect the batteries installed in the FLU-8A/P series inflator, proceed as follows:

WARNING

NO OBJECTS SHOULD BE INSERTED IN SENSOR PLUG SIDE PORTS FOR ANY REASON.

With the aid of a standard 17/32-inch socket, remove the sensor plug cap. Remove the battery and check it for leakage and corrosion. Check the sensor plug cap for cracks. The battery has a two-letter code stamped on it that corresponds with the month and year of manufacture. The date of manufacture for the battery, PN 849AS 160, is displayed in the lot number stamped on the battery case. The battery has a total life of 4 years from the date of manufacture. Replace any battery if the total life of the battery expires prior to the next calendar inspection. Check this date of manufacture on each battery. Also check the date of installation recorded on the Aviation Crew Systems History Card.

Reinstall or replace battery if needed. Ensure that the date of installation and date of manufacture are recorded on the Aviation Crew Systems History Card. See figure 6-20 for battery arrangement.

Battery Voltage Testing, LPU-23/P (Series) and LPU-24/P (Series)

Before installing any battery, you must be sure that it has enough energy to operate the FLU-8A/P inflator. A digital reading voltage multimeter must be used for this test.

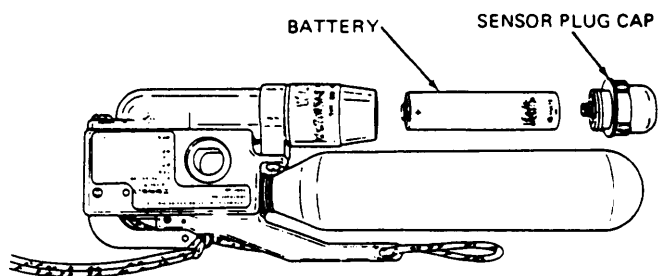

239.473

Figure 6-20.—Battery arrangement.

Do not use a needle voltage multimeter. The test leads of the multimeter should be provided with a standard test probe (+) and a banana type test plug (-). When using the multimeter, you should ensure that it is set in the voltage-measuring mode and NOT the resistance-measuring mode. A resistance measurement will trigger the squib and fire the inflator.

Insert the negative (-) test probe into the end port of the sensor plug. Remove you hand. Faulty readings can be obtained or the squib may fire if the body becomes an electrical pathway between the sensor pin and any conductive part of the inflator assembly. Now, using the pointed positive (+) probe, touch and maintain contact with one of the screw heads near the lever end of the inflator. Refer to figure 6-21.

Wait 15 seconds for the FLU-8A/P circuit to stabilize after connecting the test leads before taking the voltage reading. The voltage reading should begin at a high value and then gradually shift downward before final stabilization. If no downward shift in meter reading occurs, the FLU-8A/P inflator will be rejected.

A reading of +12 volts or more indicates the battery is at full power and installed correctly. A reading of -12 volts or more indicates the battery is installed backwards. The battery must be reversed. A reading of zero volts indicates the battery contact is faulty or the battery is not installed properly. Inspect and correct if necessary. If a correct battery voltage reading cannot be obtained with a battery of verified full charge properly installed, the inflator is defective. Reject and report for an engineering investigation according to Volume III, OPNAV 4790.2.

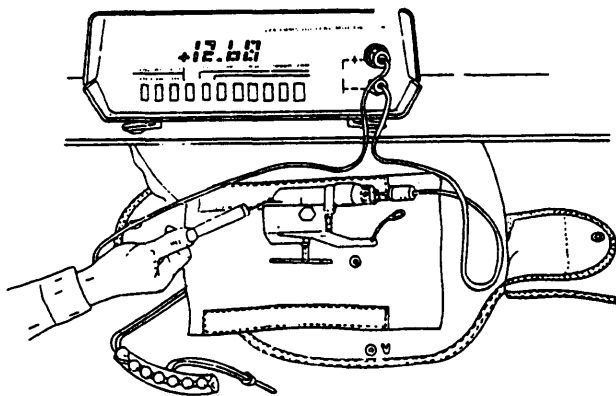

239.474

Figure 6-21.—Testing battery.

INFLATION ASSEMBLY INSPECTION

Inspect life preserver inflation assemblies as follows:

Remove the carbon dioxide cylinder from the valve assembly.

Examine the inflation device, actuating lever and lanyard, and locking pins for fraying, corrosion, stripped threads, and other damage.

If required, remove any sharp edges from the valve with a fine, round file.

On LPU-28/P, LPU-30/P, and LPP life preservers, operate the toggle three or four times. Ensure that the lever moves freely and the piercing pin moves properly inside valve body.

On life preservers with beaded inflation handles, operate beaded inflation handle three or four times. Ensure that the lever moves freely and the piercing pin moves properly inside valve body.

Ensure that the packaging cord loop is not pinched between the piercing pin and the actuating lever. If there is free play in the actuating lever when it is in its cocked position, the packaging cord loop is pinched. If necessary, reinstall the cord. Refer to NAVAIR 13-1-6.1.

NOTE: Each time the inflation assembly gaskets or the inflation assembly is removed and replaced for any reason, a functional test must be conducted. Use new gaskets when you replace the device.

If any discrepancy is noted in the inflation device that is not repairable, remove the assembly and install a new inflation device.

If carbon dioxide cylinder locking screws are installed on LPA type and LPU type life preservers, remove them.

Ensure that CO₂ cylinder locking screws are installed on LPU-30/P life preservers.

Inflation Lanyard Pull Test

Special Equipment Required

Quantity	Description	Reference Number
1	Pull-Scale, 0 to 50 lb	DPP-50 or equivalent

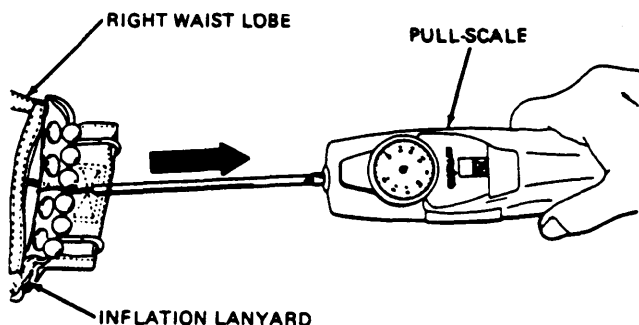

Figure 6-22.—Inflation lanyard pull test.

To perform the inflation lanyard pull test, proceed as follows:

1. Ensure that the carbon dioxide cylinders have been removed. Actuate the inflation assembly. This test is testing the lanyard itself. It isn't designed to test the pull of the inflation assembly.
2. On life preservers with beaded inflation handles, attach a pull scale to top end (end opposite inflation lanyard) of beaded inflation handle (fig. 6-22).
3. On LPP and LPA-1/1A life preservers, attach the pull scale to the actuating lanyard at the binder knot immediately above the knob.
4. Exert a 25-pound straight pull on the inflation lanyard. Remove scale.
5. Examine the inflation lanyard for frays, ruptures, thin spots, split casing, and security of knots.
6. Replace any unsatisfactory inflation lanyards.

Installation of Cylinders: LPA-1/1A (Series), LPA-2 (Series), LPU-21/P (Series), LPU-30/P, and LPP-1 (Series)

Prior to installing any CO₂ cylinder, it must be weighed and the threads cleaned. By using the cylinder thread chaser die, you turn the thread chaser to the full extent of the threads on the CO₂ cylinder to cut free any excessive cadmium plating covering the threads (fig. 6-23).

Weigh the charged cylinder and compare the stamped minimum weight with the scale weight. Discard and replace the cylinder if the scale weight is 2 grams less than stamped minimum weight. Loosen the inflator setscrew if it is installed and ensure that the inflator lever is in the cocked position. To assure a firm cylinder seat, conduct a cylinder thread count. The threaded portion of the cylinder neck must contain a minimum of seven full threads to assure a firm cylinder seat

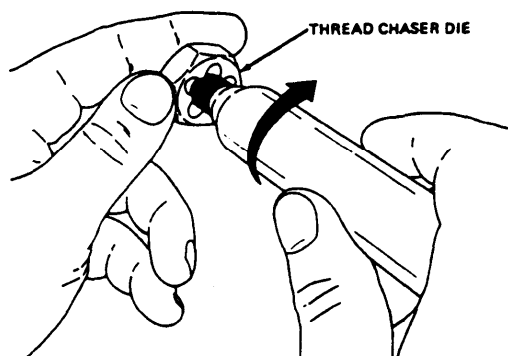

Figure 6-23.—Cleaning threads.

within the valve body. Any cylinder found with less than seven full threads must be discarded.

CAUTION

STEEL THREADS ON CARBON DIOXIDE CYLINDERS CAN CAUSE DAMAGE TO ALUMINUM THREADS ON INFLATORS IF THE CYLINDER IS NOT CAREFULLY THREADED. IF BINDING OCCURS DURING THREADING, REPLACE THE CYLINDER.

After performing a functional test, insert a new seat seal gasket from a kit. At intermediate inspection intervals, inspect the condition of the gasket and replace it if necessary. Install the CO₂ cylinder into the inflator as far as hand twisting will permit. Tighten the setscrews, if installed.

NOTE: When you replace the CO₂ cylinder to the inflator, ensure that the CO₂ cylinder passes through the holding patch loop. Do not install the setscrews in LPA-2 and LPU-21/P life preservers. For all other life preservers, a missing setscrew does not warrant removal of the preserver from service until a replacement setscrew can be obtained. Safety-wire the inflator as required.

Installation of Cylinders, LPU-23/P (Series) and LPU-24/P (Series)

To install cylinders, proceed as follows:

Weigh a charged CO₂ cylinder and compare the stamped minimum weight with the scale

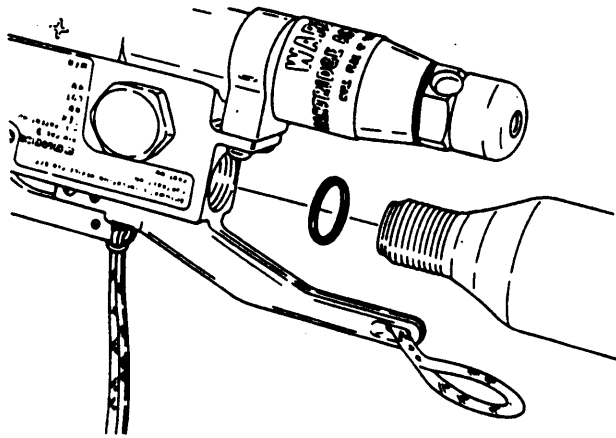

239.475

Figure 6-24.—Inserting new O-ring and CO₂ cylinder.

weight. Discard and replace the cylinder if its scale weight is 2 grams less than its stamped minimum weight.

By using the cylinder thread chaser die, figure 6-23, you turn the thread chaser to the full extent of the threads on the CO₂ cylinder to cut free any excessive cadmium plating covering the threads.

Insert new O-ring and turn the CO₂ cylinder into inflator body as far as hand twisting permits. See figure 6-24.

Battery Replacement, LPU-23/P (Series) and LPU-24/P (Series)

To replace batteries, proceed as follows:

Remove the sensor plug cap with a standard box wrench.

WARNING

BATTERIES MAY EXPLODE IF RECHARGED OR IF THEY ARE DISPOSED OF IN A FIRE.

Remove the old batteries and discard them.

CAUTION

NEVER REPLACE ONE BATTERY; ALWAYS REPLACE THE PAIR.

Remember to record the date of manufacture and the date of installation of new batteries on the Aviation Crew Systems History Card.

NOTE: Batteries have a total life of 2 years from the date of manufacture. Do not install batteries if their total life expires prior to the next scheduled calendar inspection.

Install batteries in accordance with figure 6-20.

WARNING

ENSURE THAT THE SENSOR PLUG CAP IS TORQUED TO THE CORRECT VALUE.

On FLU-8A/P only, torque the sensor plug cap to 5 in-lb using 17/32-inch socket and torque wrench.

CHAPTER 7

SEAT SURVIVAL KIT

Learning Objective: Upon completion of this chapter, you will be able to identify, inspect, and maintain the RSSK-8 seat survival kit.

The ejection seat survival kit is designed for use in ejection seat equipped aircraft only. Ejection seat survival kits are designated Rigid Seat Survival Kit (RSSKs) -1, -1A, -3, -6B2, -7, -8, and -9; Survival Kit Unit (SKUs) -2A, -3A, and 4A; and Semirigid Restraint and Life Support Assembly (IULSA) -1. The RSSK-8 is discussed in this chapter.

RSSK-8 SERIES SEAT SURVIVAL KIT

The Rigid Seat Survival Kit-8 Series (RSSK-8 series) is designed for use with Douglas

ESCAPAC ejection seats and functions as a seat cushion for the aircrewman as well as a container for an emergency oxygen system, life raft and survival equipment (shown in figures 7-1 and 7-2). There are three manufacturers of these kits—Rocket Jet Engineering Corp., Scott Aviation Corp., and East-West Industries. The illustrations in this chapter show the latest configuration of the RSSK-8 manufactured by Scott Aviation Corporation.

The RSSK-8 has a bonded fiber glass body and an extruded metal lip interconnecting the upper and lower containers. The upper container houses

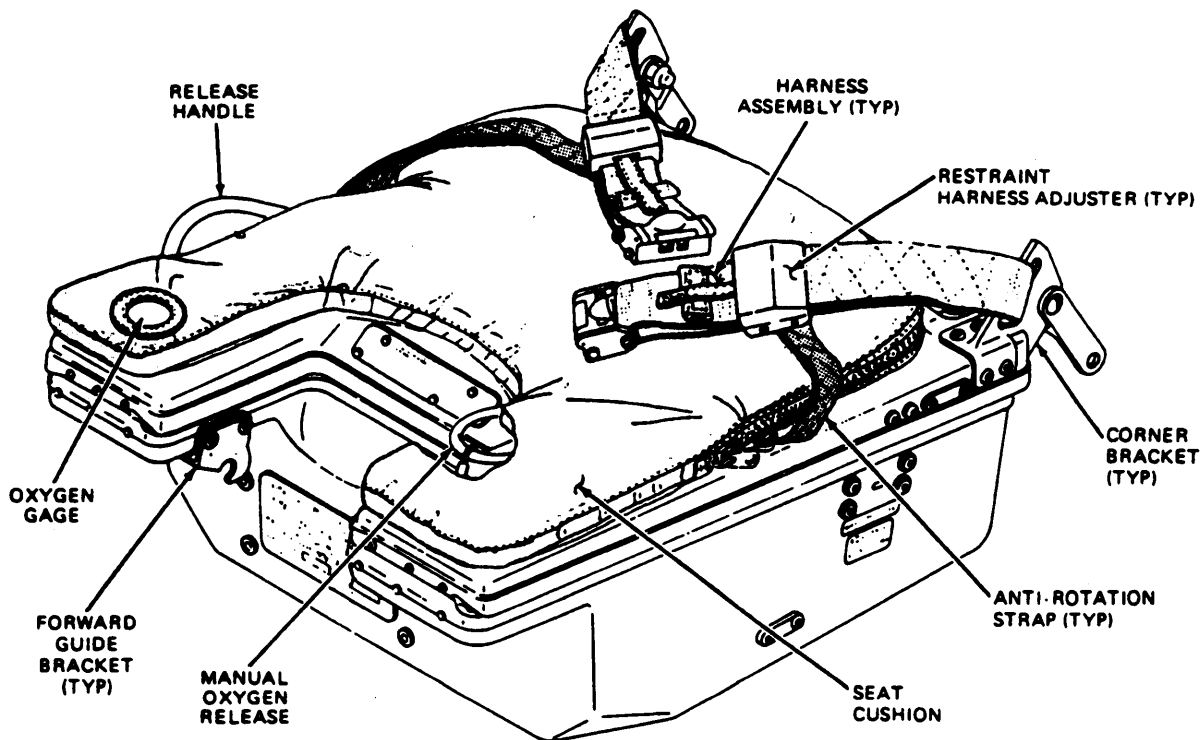

Figure 7-1.—RSSK-8 closed.

239.553

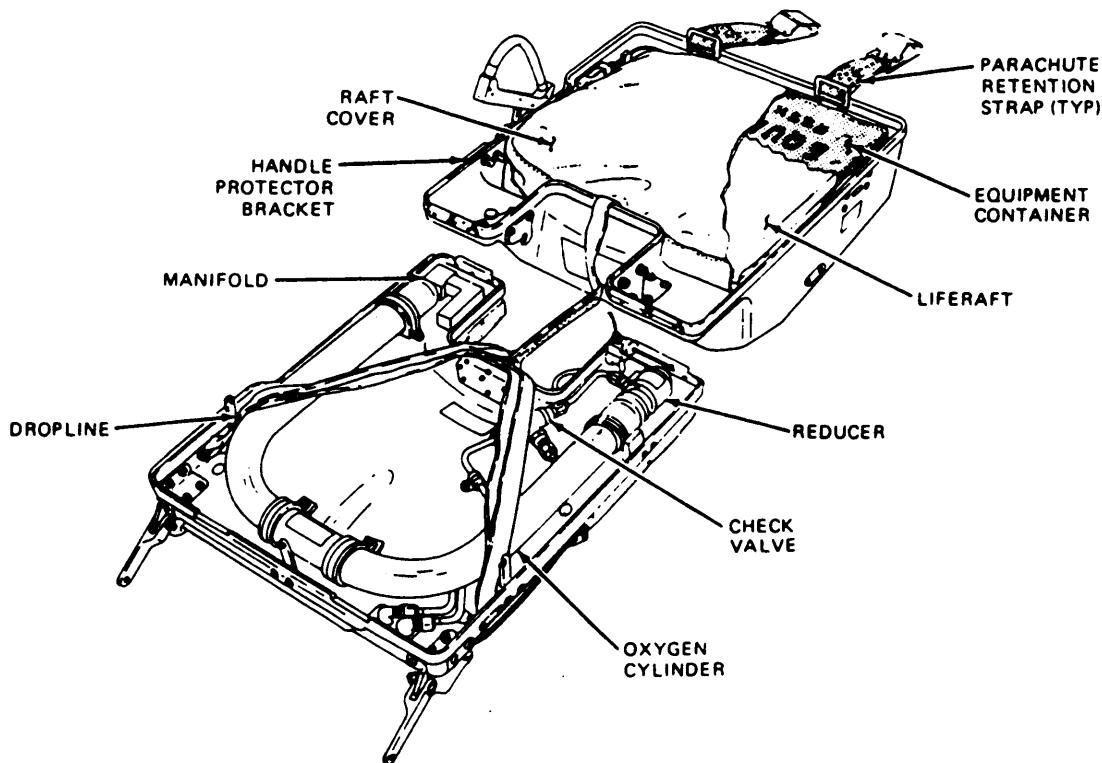

Figure 7-2.—RSSK-8 open.

239.554

the emergency oxygen supply; the lower container, the life raft and survival equipment. The kit is opened by the yellow handle mounted on the forward right side. Two adjustable retaining straps, permanently mounted on the upper container, provide attachment of the kit to the aircrewman's torso harness. A flexible oxygen and communications hose installed on the aft left side of the upper container connects the aircrewman to the aircraft for communications and oxygen functions. In the event of a failure of the aircraft oxygen system, emergency oxygen is available by pulling the manual oxygen release on the kit. Oxygen from the kit then flows to the aircrewman through the emergency oxygen system reducer in the kit. A check valve in the oxygen line prevents emergency oxygen from flowing into the aircraft system or overboard from the kit. When the aircrewman ejects, the reducer is automatically operated by a lanyard connected between the actuator and aircraft.

When he sits in the aircraft, the aircrewman connects the kit quick-release fittings to his retaining straps on his torso harness. He also connects his oxygen mask and communication

hose to the seat pan quick-disconnect fitting. This hose can be quickly disconnected by pulling sharply on the hose assembly.

The RSSK-8 is a part of the survival equipment used by aircrewman aboard the types of aircraft listed in table 7-1. As you can see,

Table 7-1.—RSSK-8 Application

Escape System	IC-2	IC-3	IF-3	IG-2	IG-3	IE-1
Aircraft	A-7A A-7B A-7C A-7E A-7H	A-4F A-4M EA-4F TA-4F TA-4J	A-4F A-4M TA-4F TA-4J	A-7A A-7B A-7C A-7E A-7H	A-4F A-4M TA-4F TA-4J	S-3A (See Note)
NOTE: Survival kits used in S-3A Type A/C must be updated to provide compatibility with AIC-14 Intercommunication Systems and the Integrated Communication Control System.						

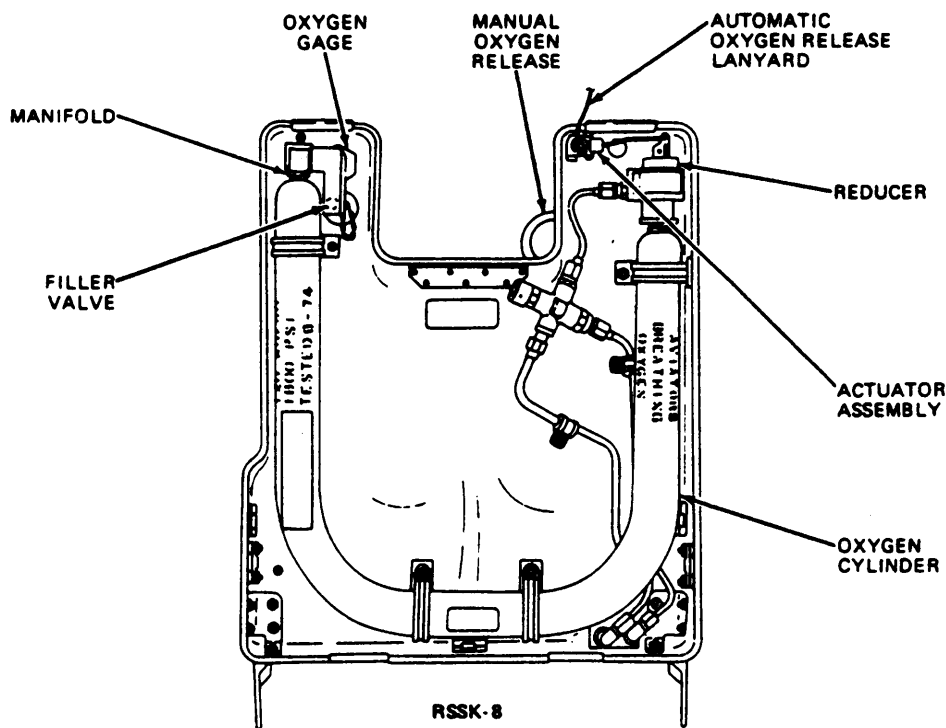

239.555

Figure 7-3.—Emergency oxygen schematic.

these are high-performance aircraft that can operate at high altitudes. Therefore, in addition to containing survival gear, the kit also furnishes oxygen to the aviator when he ejects at altitudes where there is not enough oxygen to maintain consciousness.

When the aircrewman ejects from the aircraft, the following events occur:

The automatic actuation lanyard for the emergency oxygen system actuates the reducer assembly at seat ejection. The aircrewman is then supplied emergency oxygen for descent (fig. 7-3). If automatic actuation of the emergency oxygen system fails, the emergency oxygen system may be actuated by the aircrewman by means of the manual oxygen release (green ring). The radio beacon is automatically actuated by another actuation lanyard. The beacon provides a continuous signal during descent.

When a safe altitude is reached, the aircrewman pulls the kit release handle free of the kit. This unlocks the containers and the lower half falls away but remains attached by the dropline assembly. The life raft, attached to the dropline, is automatically inflated.

INSPECTIONS

Your concern with this unit is mainly in inspecting it at scheduled intervals or when damage might be suspected. There are three types of inspections made at routine intervals: the turnaround/daily/preflight/postflight/transfer, special inspections, and the more detailed acceptance/phased/SDLM inspections. In addition, conditional inspections are unscheduled inspections required as the result of a specific situation or set of conditions; for example, hard-landing inspections or any inspection directed by higher authority that is not ordered in a technical directive.

The turnaround/daily/preflight/postflight or transfer inspections consist of a visual-type inspection performed in conjunction with the aircraft inspection requirements for the aircraft in which the survival kit is installed. These inspections are performed by line personnel (plane captain) or delegated aircrewman who have been instructed and found qualified by the aviator's equipment branch.

The special (7/14 day, etc.) inspections are performed on inservice survival kits installed in

aircraft or in ready room issue. These inspections are done at the organizational level of maintenance by personnel assigned to the aviator's equipment branch. The date of these inspections and inspector's signature are recorded in the inspection section of the Aviation Crew Systems History Card.

To perform the turnaround/daily/preflight/postflight/transfer or special inspections, visually inspect the following:

1. Cushion for secure attachment, rips, tears, and loose or grayed stitching.
2. Release handle for proper seating and corrosion.
3. Oxygen gauge for FULL indication.
4. Emergency oxygen lanyard coupling assembly for spring security.
5. Emergency oxygen lanyard for proper installation and corrosion.
6. Manual emergency oxygen release for condition and security of attachment.
7. Container assembly for cracks, breaks, and other obvious damage.
8. Harness assemblies for loose or frayed webbing, stitching, and cracked or broken hardware.
9. Lapbelt release assembly for loose or missing screws and corrosion.
10. Beacon actuator indicator for bent shaft, hairpin cotter for elongation and corrosion.
11. Secure attachment of beacon automatic actuation lanyard (if installed).
12. Seal decal for secure attachment, tears, or rips. If the seal decal is damaged, the RSSK must be reclosed by IMA.
13. Condition of oxygen hose and secure attachment to kit. If repair procedure has been performed on the oxygen hose assembly, check external wiring for secure attachment.
14. For the S-3A aircraft, secure attachment of externally mounted electrical cable assembly to oxygen hose assembly.

If any parts must be replaced, note that similar parts from kits made by different manufacturers are not interchangeable. Attempts to substitute one manufacturer's part for another may cause the kit to malfunction. Make sure the parts and assembly lists are for the proper kit when servicing a kit, or ordering replacement components for it.

If discrepancies are found or suspected, maintenance control must be notified.

Survival kit assemblies that do not pass inspection and cannot be repaired in the aircraft

must be removed and replaced by Ready for Issue (RFI) survival kits. Non-RFI survival kits are forwarded to the nearest maintenance activity having repair capability.

ACCEPTANCE/PHASED/SDLM INSPECTIONS

The acceptance inspection is performed when the survival kit is placed into service. When a survival kit is an aircraft inventory item, the acceptance inventory inspection and packing serves as the acceptance inspection. In this case, the records concerning the RSSK must be examined. Phased/SDLM inspection cycle of a survival kit corresponds to the aircraft phased/SDLM maintenance inspection cycle as scheduled by the Planned Maintenance System. In no case should the phased interval exceed 225 days.

Visual Inspection

This inspection will be performed prior to the functional check of the kit. Visually check the kit for the following:

1. The cushion for rips, tears, and general condition.
2. The release handle for wear, corrosion, and damage.
3. The manual emergency oxygen release handle (green ring) for damage and security of attachment.
4. The upper and lower container for cracks, corrosion, and security of hardware.
5. Webbing for loose or frayed stitching and security of attachment.
6. The lapbelt release assembly for loose or missing screws and corrosion.
7. Swaged balls on cable assemblies for security of attachment. The swaged ball pull test is performed during the acceptance inspection only.

Swaged Ball Pull Test

To check the swaged ball attachment to cable assemblies, you will need a nylon cord, Type II scale (at least 100-pound capacity). Perform the pull test as follows:

1. Remove four screws and cover from assembly.
2. Push actuating lever down (fig. 7-4).

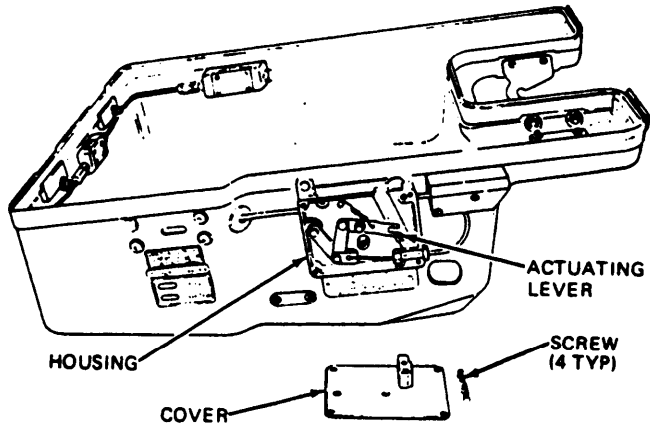

Figure 7-4.—Pushing actuating lever down.

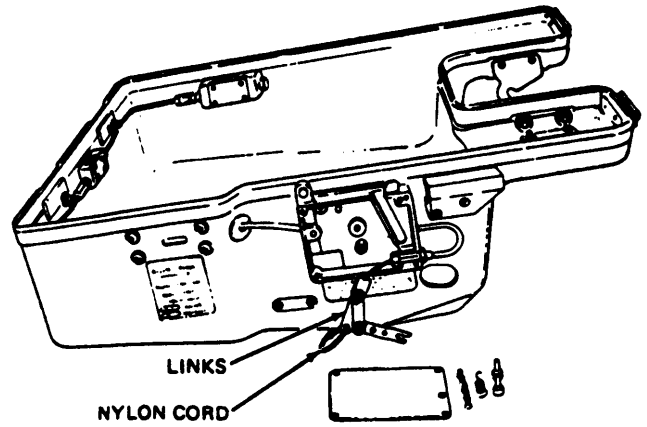

Figure 7-6.—Tying links together.

3. Remove spring and two spacer pins. Lift actuating lever assembly with cable inserted in clevis from housing (fig. 7-5).

4. Thread approximately 5 inches of nylon cord, MIL-C-5040, through "LINKS" and tie both ends together (fig. 7-6).

5. Insert hook of scale into loop of nylon cord (fig. 7-7).

6. Pull the scale towards aft direction of kit and in the normal direction of cable operation. Ensure the adjusting sleeve does not move from its housing while pull force is exerted. Ensure that the links and clevis are not pulled from the housing more than 1/2 inch. Swaged balls should withstand 100 pounds pull force (fig. 7-8).

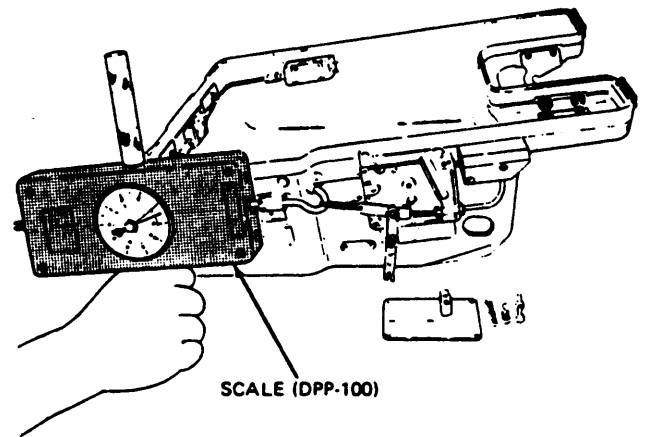

Figure 7-7.—Attaching scale to nylon loop.

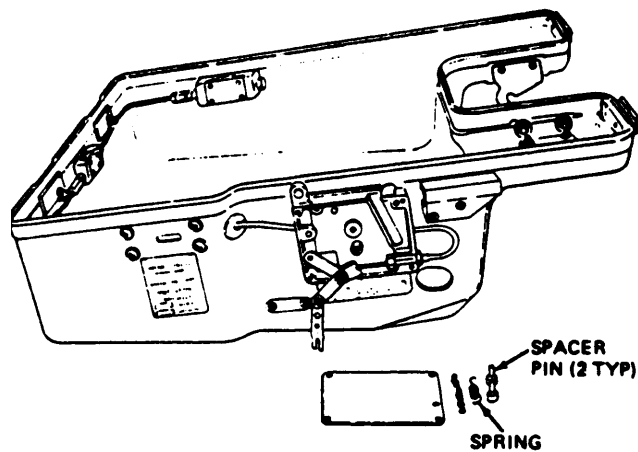

Figure 7-5.—Removing spring and spacer pins.

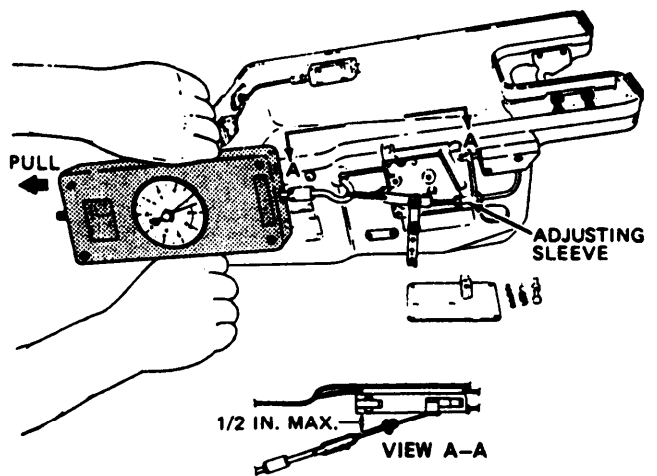

Figure 7-8.—Testing swaged ball.

Table 7-2.—Troubleshooting

Trouble	Probable Cause	Remedy
Low or zero pressure indication on oxygen gage.	Oxygen tube empty.	Recharge oxygen system.
	Defective pressure gage.	Replace gage.
	Oxygen system components are leaking.	Tighten connections or replace defective parts as required.
No oxygen flow at kit-to-man hose from aircraft system (emergency oxygen system not actuated).	Defective check valve.	Replace check valve.
Oxygen pressure at kit-to-man hose not within tolerance of 45 to 80 psi when emergency oxygen system actuated during test.	Defective oxygen reducer/manifold.	Replace oxygen reducer/manifold.
	Oxygen reducer/manifold incorrectly adjusted.	Adjust and test reducer/manifold.
Relief Valve Leakage.	Defective Quad-Ring.	Disassemble, remove and replace Quad-Ring P/N 4008 (FSCM 07322).
Relief Valve does not operate within tolerance of 120 to 140 psi when simulated aircraft back pressure is applied during test.	Defective or out of adjustment relief valve.	Adjust relief valve in accordance with NAVAIR 13-1-6.3. If specification cannot be met replace relief valve.
Oxygen flow exists at ship-to-kit hose when emergency oxygen system is actuated during test.	Defective check valve.	Replace check valve.
No oxygen flow at kit-to-man hose when emergency oxygen system is actuated by emergency oxygen lanyard or emergency manual oxygen release.	Upper and lower adjuster or oxygen actuator assembly not adjusted correctly; Oxygen lanyard or manual release pulls free of actuator assembly before reducer/manifold toggle arm is operated by actuator cables.	Adjust oxygen actuator assembly.
Pull force to actuate emergency oxygen system by emergency oxygen lanyard or emergency manual oxygen release is not within tolerance of 10 to 30 pounds.	Excessive or insufficient washers beneath toggle arm of reducer/manifold assembly.	Adjust and test reducer/manifold.
	Foreign matter in actuator.	Clean actuator assembly.
	Expanded diameter of retaining ring on emergency manual oxygen release causing an increased retention load within adjuster of oxygen actuator assembly.	Replace oxygen actuator assembly.
	Burrs and corrosion on grip assembly and adjuster nut.	Polish off burrs and corrosion and lubricate.
Emergency lanyard coupling assembly loose.	Broken or missing spring.	Repair in accordance with NAVAIR 13-1-6.3.
Operation of handle fails to separate upper from lower container.	Lock actuating cables out of adjustment.	Adjust cables.
	Broken, crushed or bent lock actuating cable assembly.	Replace discrepant cable.
	Damaged lock.	Replace discrepant lock.
	Pin opposite slot on disk in multi-release assembly has sheared (Rocket Jet only).	Replace multi-release assembly.
	Swaged ball slipped off cable.	Install new swaged ball on cable.
Handle does not release from kit within tolerance of 10 to 30 pounds.	Latch in handle not clearing latch engagement projection on multi-release housing during handle operation.	Adjust position of latch on guide.
	Broken, crushed or bent lock actuating cable assembly.	Replace discrepant cable.
	Damaged lock.	Replace discrepant lock.
Loss of aircraft communications.	Broken or misaligned pins and sockets in hose connectors. Open or short circuit in oxygen hose wiring.	Perform electrical check.

7. If the assembly fails to meet the specified pull force, slide the ball off the cable and swage a new ball in the same direction.

8. Assemble the parts and install the cover on the housing.

Functional Check

This check will be performed at each acceptance/phased/SDLM inspection. It will also be performed after any adjustment procedures. Refer to Troubleshooting Chart (table 7-2) prior to making any adjustments.

Materials required to perform the functional check include test stand 59A120 (test stand 59A120 is covered in detail in chapter 11 of this manual), scale (0 to 50 pounds), leak detection compound, and a toggle reset tool.

Inspect leak detection compound before using it. Compound that is not clear and free from suspended material or sediment is considered contaminated and must be disposed of. Compound exhibiting peculiar odors such as acetone or alcohol is considered contaminated and must be disposed of.

Emergency oxygen cylinder pressures used in this functional test are taken under ideal shop conditions of 70°F or 21°C. Variances in air temperatures directly affect charging pressures. Refer to table 7-3 for details.

Ensure that the emergency oxygen cylinder is filled to 1,800 to 2,000 psi corrected pressure.

1. Connect the oxygen outlet hose of the kit to the bell jar coupling C-1 on the test stand, and ensure that valve V-2 is open and all other test stand valves are closed.

2. Attach the pull scale to the manual emergency oxygen release handle, and test for disengagement force. Ensure the manual oxygen release is of the separating type before attempting to disengage it.

3. Measure the force required to disengage the manual oxygen release. This should be 10 to 30 pounds, and the emergency oxygen system should actuate and indicate 45 to 80 psi on gauge PG-1 on the test stand.

4. Reinstall the manual oxygen release (if separating type) and reset the reducer.

5. Turn the oxygen supply cylinder to the test stand on.

6. Slowly open valve V-6 on the test stand and adjust the pressure on gauge PG-1 to 90 psi.

Table 7-3.—Amb-nt Air Temperature vs Charging Pressures

Ambient Air Temperature		Charging Pressure
°F	°C	PSI
0	- 1 8	1550-1750
10	- 1 2	1600-1775
20	- 7	1625-1800
30	- 1	1675-1850
40	5	1700-1875
50	10	1725-1925
60	16	1775-1975
70	21	1800-2000
80	27	1825-2050
90	32	1875-2075
100	38	1900-2125
110	43	1925-2150
120	49	1975-22(X)
130	54	2000-2225

7. Measure the force required to disengage the manual oxygen release with a scale. This force should be 10 to 30 pounds.

8. Using leak test compound, check all pressure lines and fittings on the kit for leakage. No leakage is allowed.

9. Reinstall the manual oxygen release (if separating type) and reset the reducer.

10. Using valve V-6, increase pressure until the relief valve unseats. However, do not increase the pressure above 150 psi. Unseating can be determined by listening, and by observing gauge PG-1 on test stand.

11. Repeat step 10 several times to establish a correct pressure. Relief valve will unseat at 120 to 140 psi when pressure is increased, and reset at 110 psi minimum when pressure is decreased. The pressure is reduced below the opening pressure of the relief valve by closing valve V-6 and opening bleed valve V-5. Once reset, the relief valve will be leaktight.

12. Check the relief valve with leak test solution. No leakage is allowed.

13. Close valve V-6 and bleed oxygen pressure from the system by opening valve V-5. All pressure is bled when gauges PG-1 and PG-4 indicate zero pressure.

14. Close valve V-5.

15. Ensure that bleed valve V-2 is opened and all other test stand valves are closed.

16. Measure the force required to disengage the automatic oxygen release with a scale. This force should be 10 to 30 pounds when it disengages; the emergency oxygen system should actuate and indicate 45 to 80 psi on gauge PG-1.

17. Reset the reducer.

18. Open valve V-5 to bleed pressure.

19. When pressure is bled, as indicated by no indication on gauges PG-1 and PG-4, close valve V-5. Now, observe gauge PG-4 for 2 minutes. Any pressure rise indicates leakage in the valve seat of the reducer/manifold.

20. Open valve V-5 and close valve V-2.

21. Disconnect the oxygen hose from fitting C-1.

22. Ensure all valves on the test stand are secured.

23. Connect the oxygen outlet hose to fitting NIP-6. Ensure that valve V-10 is open and all other test stand valves are closed.

24. Connect the test stand hose between fitting NIP-5 and fitting NIP-4.

25. Move valve V-1 to the NIP-4 position.

26. Ensure that 1,800 to 2,000 psi is in the oxygen cylinder of the kit.

27. Pull the manual oxygen release. Slowly open valve V-9 to indicate 90 liters per minute on gauge PG-2. Oxygen pressure should be indicated as 45 to 80 psi on gauge PG-1.

28. Observe emergency oxygen cylinder pressure gauge and allow the system to decrease to 250 psi while maintaining 90 LPM and 45 to 80 psi pressure. When needle of this cylinder pressure gauge is between the E and F of REFILL, pressure is approximately 250 psi.

29. Close valve V-9.

30. With zero flow indicated on gauge PG-2, gauge PG-1 should indicate 45 to 80 psi.

31. Reinstall the manual oxygen release (if separating type) and reset the reducer.

32. Bleed the oxygen pressure from the system by opening valves V-5 and V-2. All pressure is bled when gauges PG-1 and PG-4 indicate zero pressure.

33. Disconnect the kit from the test stand.

34. Secure the test stand.

35. Thoroughly clean all areas wetted with leak test solution with clean water. Dry them with a lint-free cloth, filtered low-pressure compressed air, or by low-pressure nitrogen.

36. Recharge the emergency oxygen cylinder to 1,800 to 2,000 psi.

37. Perform a release handle pull test on the fully packed kit. (Refer to NAVAIR 13-1-6.3 for instructions.)

PURGING AND CHARGING EMERGENCY OXYGEN SYSTEMS

To purge and charge the emergency oxygen cylinder, proceed as follows:

Materials Required

Leak detection compound

Oxygen purging electric heater

Nitrogen, type I, class I, grade A

Aviator's breathing oxygen, type I

Shutoff valve

Pressure regulator

Adapter, filling

1. If the survival kit assembly has not been removed from the aircraft, remove the personnel parachute and survival kit in accordance with the applicable maintenance manual.

2. Remove the oxygen filler valve cap and connect a filling adapter to the filler valve (fig. 7-9). If the emergency oxygen system is

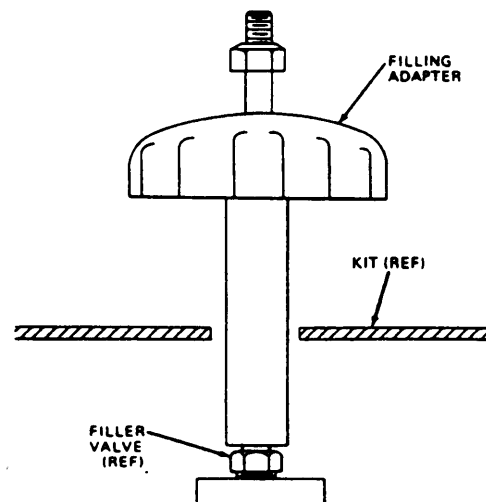

Figure 7-9.—Filling adapter.

contaminated or the cylinder has remained empty for more than 2 hours, purging is required. If an emergency oxygen cylinder does not warrant the purging process, proceed to step 10 for the charging sequence. If it is necessary to release pressure in the oxygen bottle before purging/filling, pull the emergency oxygen lanyard. This releases the pressure through the pressure reducer. DO NOT release pressure through the filler valve or adapter. Releasing high-pressure oxygen through the restriction of the filler valve causes heat, and a fire or an explosion may result.

3. Deplete the emergency oxygen cylinder, if necessary.

4. Connect a nitrogen source to the filling adapter and close the pressure reducer.

5. Slowly pressurize to 100 psi with a nitrogen temperature of 110° to 130°C (230° to 266°F) using an electric heater.

6. Turn off the nitrogen source and deplete the oxygen cylinder.

7. Repeat steps 5 and 6, twice.

8. With the pressure reducer open, turn on the nitrogen source and purge for 10 minutes at a temperature of 110° to 130°C (230° to 266°F).

9. Turn off the nitrogen source and disconnect it.

10. Connect the oxygen source to the filling adapter with a suitable pressure regulator and shutoff valve. Reset the pressure reducer.

11. Slowly pressurize to 100 psi.

12. Deplete the cylinder to 50 psi.

13. Ensure that minimum slack exists in the actuating cables of the reducer/manifold, and that they are tight enough to ensure full engagement of the toggle arm.

14. Charge the emergency oxygen system in stages in accordance with table 7-4 until the pressure gauge indicates correct pressure for existing ambient temperature, as indicated in table 7-3. Carefully observe the scheduled filling stages, since rapid application of oxygen pressure creates

Table 7-4.—Charging Stages

Stage	PSI
1	500
2	1000
3	1500
4	1800
5	2000

heat, which may result in fire or explosion. Allow no less than 3 minutes for each filling stage and 2-minute intervals for cooling between stages. If the kit is to be stored or shipped, fill it to 200 psi (when needle on gauge bisects E of REFILL).

15. Loosen the filling adapter until all pressure is bled from the high-pressure line. Remove filling adapter. Visually ensure that the filler valve does not turn as the filling adapter is removed. Serious injury could result.

16. Apply leak test compound around the filler valve, gauge, and reducer. Check for leaks; then wipe connections clean, using a lint-free cloth.

17. Replace the oxygen filler valve cap on the filler valve.

18. If the personnel parachute and survival kit assembly were removed from the aircraft in step 1, reinstall them at this time.

As you know, there are a variety of seat kits available. Although the basic principles of operation are similar, they differ in accordance with the aircraft in which they are issued, their contents, and the type of ejection seat in the aircraft. Additional information concerning updating, modification, inspection, maintenance, etc., of seat survival kits can be obtained from NAVAIR 13-1-6.3. *Aviation Crew Systems Seat Survival Kits.*

CHAPTER 8

CARBON DIOXIDE

Learning Objective: Upon completion of this chapter, you will be able to describe, inspect, recharge, and perform maintenance on carbon dioxide cylinders and transfer units.

Carbon dioxide is a heavy, colorless gas. The chemical symbol for carbon dioxide is CO₂. You will find that most people use this symbol when referring to carbon dioxide.

CO₂ doesn't burn and does not support combustion; therefore, it makes a fine fire-fighting agent. It is strongly recommended for use on electrical fires. The servicing of fire-fighting equipment is not part of the PR rate, and so this text does not cover fire extinguishers.

As a PR you deal with life raft and life preserver CO₂ cylinders, which you weigh, recharge, and repair.

Carbon dioxide is ordinarily procured from local commercial sources. It is stored in standard supply cylinders that contain 50 pounds of carbon dioxide when full.

Before learning how to recharge CO₂ cylinders, you should be familiar with the following information:

In its gas form, carbon dioxide is 1.53 times heavier than air. CO₂ gas can be converted into a liquid by applying pressure to the gas. With as little as 600 psi at a temperature below 88°F, the CO₂ gas can be converted into a liquid and stored in that state until it is subjected to the outside atmosphere. By opening the cylinder valve and letting the carbon dioxide escape into the atmosphere, you cause a rapid drop

in pressure. As the CO₂ escapes through the small opening, it forms carbon dioxide snow. This snow, when compressed into blocks or cubes, is known as dry ice. At atmospheric pressure, dry ice will remain at -110°F, directly evaporating into CO₂ gas. CO₂ exists as a liquid only when under pressure.

Whenever you are working with CO₂ in any of its three stages—gas, liquid, or dry ice, you should be aware that small percentages of CO₂ in the air causes tiredness and perhaps headaches. Experiments have shown that a 3-percent concentration in the air doubles your breathing effort, 5 percent causes panting, 8 percent causes marked distress, and 10 percent causes unconsciousness very quickly.

Treatment of exposed personnel includes removing them from the CO₂-laden atmosphere, artificial resuscitation, administering oxygen, and keeping the patient warm.

CO₂ RECHARGE EQUIPMENT

Carbon dioxide recharge equipment is manufactured for the Navy by several different companies. The two most widely used units are those manufactured by the C-O-TWO Company of Newark, New Jersey (do not confuse this company with the chemical symbol CO₂) and the Walter Kidde Company of Belleville, New Jersey.

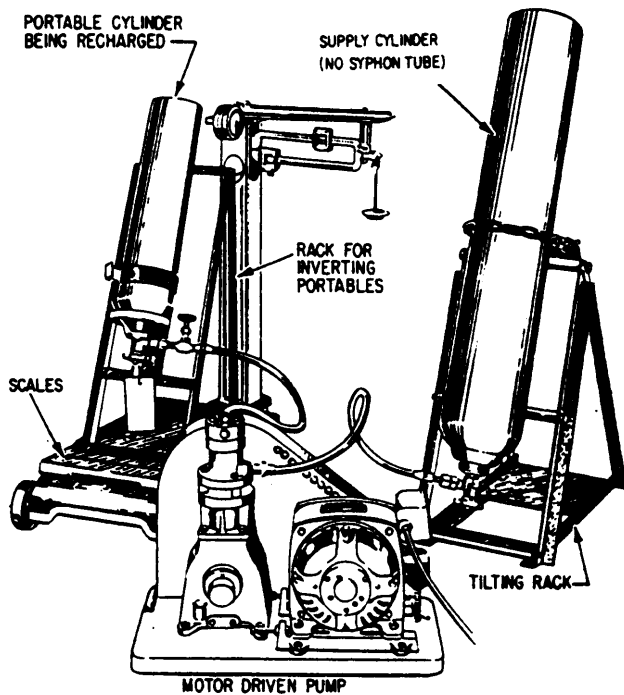

239.39

Figure 8-1.—C-O-TWO recharge or transfer unit (supply cylinder without a syphon tube).

A typical C-O-TWO recharge unit is shown in figure 8-1 and consists of a supply cylinder containing 50 pounds of CO₂, a tilting rack for inverting the supply cylinder, a motor-driven pump, a rack for inverting the cylinder being recharged, a scale for determining the weight of the cylinder being recharged, and the necessary high-pressure hoses, control valves, adapters, etc., to properly hookup the equipment. The two units are covered in detail in the *PR 1 & C*.

Before learning the operation of any specific type of recharge equipment, you should be familiar with the following general information, which applies to all units.

Carbon dioxide recharge equipment pumps CO₂ in its liquid state only, and the amount of liquid CO₂ a cylinder contains varies with the temperature and pressure. For example, a standard 50-pound supply cylinder contains approximately 38 pounds of liquid CO₂ and 12 pounds of gaseous CO₂ at a temperature of 70°F. It follows, then, that the cooler the supply cylinder and cylinder being recharged, the more efficient the operation of the transfer equipment. For this same reason, the time required to recharge an empty cylinder increases with the temperature of the cylinders.

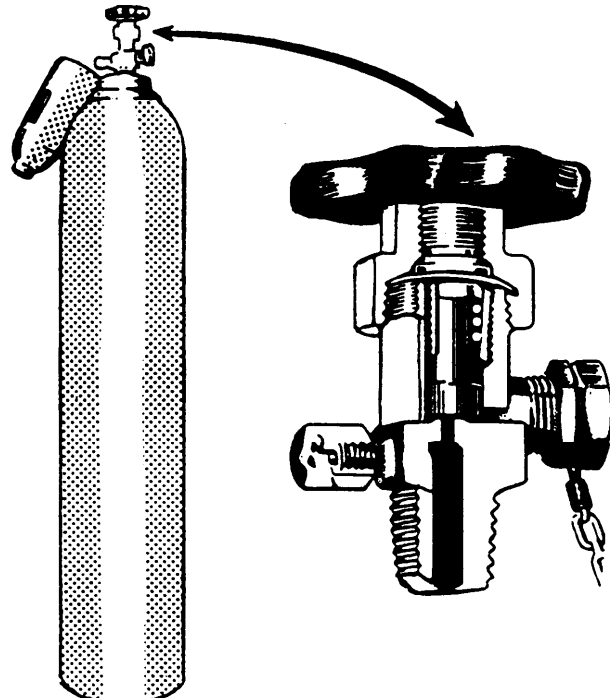

239.144

Figure 8-2.—CO₂ supply cylinder.

When recharging a cylinder, it remains cooler and may be filled faster if inverted, rather than left in an upright position. Large cylinders, which are impractical to invert, may be placed in a horizontal position for charging.

Standard commercial supply cylinders in 50-pound sizes are obtained with or without a syphon tube. When transferring from a cylinder without a syphon tube, the cylinder must be inverted. Supply cylinders with syphon tubes should be maintained in an upright position, not more than 60 degrees from vertical.

CO₂ SUPPLY CYLINDERS

Figure 8-2 illustrates the standard supply cylinder used universally in recharging various types of CO₂ cylinders. A cutaway view of the cylinder valve is also shown. Table 8-1 lists some of the most pertinent data concerning supply cylinders.

INSPECTING CO₂ CYLINDERS AND RECHARGING

Cylinders, including some of those of new manufacture, continue to bear ICC markings and,

Table 8-1.—Specifications On Supply Cylinders

Capacity at normal pressure and temperature*	50 pounds
Working pressure	1,800 to 2,015 psi
ICC specification	ICC3A
Dimensions (approx.)	Diameter, 8 1/2 inches; length, 51 inches
Weight, empty	110-115 pounds
Outlet connection	3/4 inch

* Temperature of 68° - 70°F and atmospheric pressure.

until amendment to Department of Transportation (DoT) regulations, such markings will remain in use.

Compressed gas cylinders, including CO₂ cylinders must not be refilled if the hydrostatic test date has expired. This date, expressed by month-year, e.g., 8-70, is stamped on the shoulder of the cylinder each time the cylinder is retested. The hydrostatic test date is considered as having expired if the latest date stamped on the cylinder precedes the current date by more than 5 years.

Cylinders that do not exceed 2 inches in outside diameter and that are less than 2 feet long are exempt from the hydrostatic retest.

The hydrostatic retest date applies to multi-
place life raft cylinders; if the cylinder is due for a test, discharge and disconnect the cylinder. Obtain a new cylinder from supply as a replacement, and forward the old cylinder to an activity capable of conducting a hydrostatic test.

Many nonshatterable cylinders are identified by the words NONSHATTERABLE, NONSHAT, or SHATTERPROOF stamped (not stenciled) on the shoulder or side of the cylinder. Substitution of a “shatterable” for a “non-scatterable” cylinder is not authorized.

Personnel who handle compressed gas cylinders must be familiar with the color coding of cylinders. Color coding is provided as a hazard warning, and should not be used by itself to identify the contents of a cylinder. In the event of

conflict with other markings, or doubt as to the contents, the cylinder should be returned to the local supply activity, (non-RFI).

All carbon dioxide inflation cylinders must be painted gray, and markings must be in black letters 1/4-inch high. The information must include gross weight, tare weight, weight of carbon dioxide, and date of latest recharge. Paint and stencil the cylinder as required, and ensure that all markings are included as necessary.

Ensure that all carbon dioxide cylinders used for life raft inflation assemblies received from supply, except those used on the one-man rafts, have syphon tubes installed.

Gently tap the inverted cylinder with a small piece of wood. If any rust or other contamination falls from the cylinder, reject that cylinder, and draw another cylinder from supply; repeat the contamination check. Replace the stem in the inflation assembly valve, install a new sealing washer, and thread the inflation assembly valve onto the cylinder and tighten.

Inspection for deterioration of the cylinder will consist of a visual examination for the defects listed below.

Cylinders with defects that approximate the physical dimensions indicated in the following list will be condemned and returned to supply.

1. Corrosion pits in a general corrosion area that exceed a depth of 1/32-inch, or isolated pits not in a general corrosion area that exceed a depth of 5/64-inch.
2. Dents that exceed a depth of 1/16-inch, or whose major diameter is more than 32 times the depth.
3. Cuts or gouges more than 1/16-inch, or whose major diameter is more than 32 times the depth.
4. Visible arc or torch burns.
5. Evidence that the cylinder has been in a fire.
6. Discernible bulges.

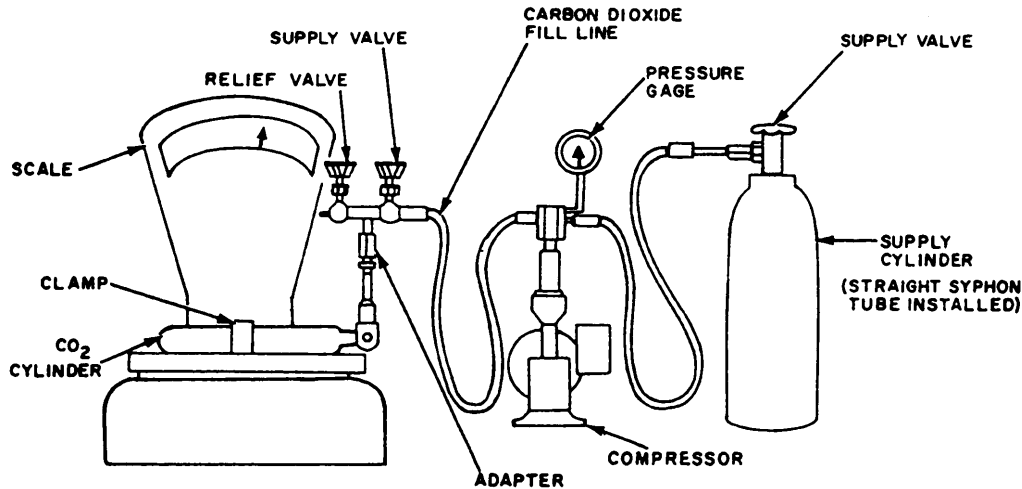

239.359

Figure 8-3.—CO₂ recharging schematic.

Now that you have inspected the CO₂ cylinder, you are ready to recharge the bottle. Figure 8-3 shows a recharging setup. Notice in the figure that you need scales, a recharge pump, a supply cylinder, and the necessary lines and valves. Proceed as follows:

1. Place the CO₂ cylinder on the scales.

NOTE: An accurate scale with a capacity of 100 pounds is necessary. The scale should have 1/100 pound graduations.

2. Weigh and record tare weight (empty weight of cylinder, valve and cable assembly) of the inflation assembly.

3. Install proper charging adapter on the inflation assembly.

4. Secure the inflation assembly to the weighing pan located on the scales before applying any pressure to the cylinder being recharged.

5. Open the supply cylinder valve, fill line valve, and relief valve. This is done to purge (get the air out of) the complete line. Once the line is purged, close the fill line valve and the relief valve. You must be careful when purging the line; you are dealing with a high pressure. If you do not secure the fill line before you apply pressure, the line may start a whipping action and damage anything or anyone that it hits.

6. After purging the line, connect the fill line to the inflation assembly. Ensure that the line is free from contact with any objects along the entire distance from the compressor to the charging

Table 8-2.—Carbon Dioxide Charge

RAFT TYPE	WEIGHT (IN Lbs) OF CO ₂
LR-1	0.49 to 0.51
LRU-7/P	0.49 to 0.51
LRU-12/A	3.21 to 3.29
LRU-13/A	4.64 to 4.76
LRU-14/A	4.74 to 4.86
LRU-15/A	9.14 to 9.26

adapter. If the line does not hang free, accurate weight reading cannot be obtained. At this time, you must zero your scales. By zeroing the scales, you will be able to recharge the exact amount of CO₂ into the inflation assembly. See table 8-2 for carbon dioxide charges.

7. Ensure that the inflation assembly valve is open. If it is closed, you cannot recharge the assembly.

8. Open the fill line valve slowly until you hear CO₂ flowing through the line and into the inflation assembly, and the scale's indicator shows the recharging cylinder is gaining weight.

9. Allow carbon dioxide to cascade (flow freely) from the supply cylinder until the scales

indicate that the cylinder being recharged isn't receiving anymore CO₂. If you haven't reached the gross weight required (tare weight plus weight of charge) start the compressor and complete charging. Stop the compressor upon reaching the proper gross weight. At this time, you have completed the recharging process, and you must secure the equipment.

10. To shut the equipment down, start by securing the inflation assembly valve, and shut off the compressor. Then secure the fill line valve. Open the relief valve; this will relieve any pressure you may have in the line between the fill line valve and the inflation assembly. Disconnect the fill line from the inflation assembly and remove the charging adapter. To secure the rest of the system, all you have to do is close the supply cylinder valve and bleed the system by opening the fill line valve.

If, during the recharging process, the cylinder being charged ceases to gain in weight, there may be one of two things wrong:

1. The supply cylinder may contain less than 10 pounds of carbon dioxide. In this case, a fully charged supply cylinder should be used and the partially charged cylinder reserved to start the recharging of an empty cylinder.

2. The connecting lines may have become stopped up with carbon dioxide snow. This may be caused by water in the supply cylinder or too small a valve passage (less than 1/8 in) in the supply cylinders. In this case, the disc assembly (disc-type valve) or the cylinder valve (seat-type valve) should be securely seated and the pump shut off. The connections should be broken and cleared of the carbon dioxide snow. The line will actually clear itself if allowed to stand for some length of time, but this can be hastened by applying a flame or torch to the tubing. The line should then be blown out with air to clear it of water or foreign matter.

MAINTENANCE FOR THE C-O-TWO TRANSFER UNIT

Once every month, inspect the level of the oil in the crankcase and see that it is within the limits specified.

Once every 6 months, lubricate the idler shaft with two or three applications of light cup grease; also, lubricate the gear teeth with a thin coating of the same grease. With a small brush, apply a

light coating of Vaseline to the piston rod. To do this, dip the brush in Vaseline and hold the brush against the piston rod while rotating the gears manually until the piston rod has been coated completely. If necessary, tighten the packing at the piston stem. A special wrench is needed for this operation. Do not tighten excessively. Because of the design of the packing, it is necessary to make only a snug adjustment to have it hold tightly.

Keep the commutator or the motor clean. Under normal operating conditions, the commutator will require only occasional cleaning with a dry piece of nonlinting cloth. Never lubricate the commutator.

Drain and refill the crankcase at least once a year. The bearing housings of the motor, which also need attention at this time, should be cleaned and regressed by a qualified electrician. Use table 8-3 for servicing intervals.

MAINTENANCE OF THE WALTER KIDDE TRANSFER UNIT

The instruction book on lubrication for the Walter Kidde transfer unit recommends inspecting the oil level in the crankcase periodically and changing it as necessary. Here, experience with pumps dictates the time of action. One can establish and maintain a schedule compatible with the experience gained through operating the equipment. The plunger packing needs no oil.

Table 8-3.—C-O-TWO Unit Servicing Intervals

ITEM CHECKED OR SERVICED	MONTHS		
	1	6	24
CRANKCASE OIL LEVEL	X		
IDLER SHAFT		X	
GEAR TEETH		X	
PISTON ROD		X	
PISTON STEM PACKING		X	
MOTOR COMMUTATOR		X	
DRAIN AND REFILL CRANKCASE			X
MOTOR BEARING HOUSINGS			X

CHAPTER 9

SEWING MACHINES

Learning Objective: Upon completion of this chapter, you will be able to identify and maintain the different types of sewing machines used in the process of repairing or fabricating survival equipment.

Sewing machines are like any other tool you use. If you don't have the correct one, the task is harder or impossible to complete. The same applies to sewing machines. You need the right machine for the job; whether it be lightweight, medium weight, or heavyweight, there is a machine designed to perform each task. You work with various types of sewing machines in the process of repairing or fabricating items in the shop. You need to have all the knowledge and skill YOU can possibly acquire about these machines to fulfill your duty as a PR. If you don't know how to operate and maintain the sewing machines, they will stand idle, not operate properly, or not work at all. When you have a job to do, you need equipment that is operational. Without the proper knowledge of sewing machines, you will not have the confidence to perform necessary sewing machine repairs.

Before you can learn to operate and maintain a sewing machine, you must learn the language of the sewing trade. Through your supervisor and this text, you should become familiar with this language. It is very important that you form a habit of referring to the parts of a sewing machine by their proper names. It would be difficult to communicate with other PRs and impossible to pass a rating exam if you do not know the proper names of the different parts of a sewing machine. Take time to study the illustrations in this chapter that show the important sewing machine parts and their names.

Sewing machines are classified as two types—OSCILLATING and ROTARY. Both types are operated by electric motors and are fitted with rheostats and special clutch arrangements that enable the operator to control the speed.

When it comes to classifying sewing machines into oscillating and rotary, the important part is

the rotary hook and oscillating shuttle. This is the device that is out of sight in the base of the machine, but does the very important job of forming each stitch after the needle has passed thread through the fabric.

Oscillating sewing machines have a sewing hook that rocks back and forth through half of one revolution to complete one stitch.

Rotary sewing machines have a hook that makes two complete revolutions to complete one stitch.

The type of stitch commonly used and made by sewing machines in repair work is the lockstitch. The lockstitch makes use of two separate threads. One comes from the spool down through the eye of the needle, the other from the bobbin. In making the lockstitch, these two threads must become interlocked, as shown in figure 9-1.

The thread passing through the eye of the needle is pushed down through the material being sewn. As the needle travels downward to the material, a spring pulls tension on the needle thread to keep it taut to prevent any slack that might tangle the thread around the needle.

After the needle reaches its lowest position and starts its upward movement, the process shown in figure 9-1 begins. A small loop of thread forms alongside the needle beneath the throat plate. The sewing hook catches this loop and carries it around the bobbin, which floats in its track in the bobbin case (view B of figure 9-1). By locking the loop of needle thread around the bobbin thread, the sewing hook forms the stitch.

As the needle completes its upward movement, the thread tension disks hold the needle thread firmly. The thread take-up lever, rising quickly, pulls on the loop that has been formed, and thus tightens the stitch. When the thread take-up lever

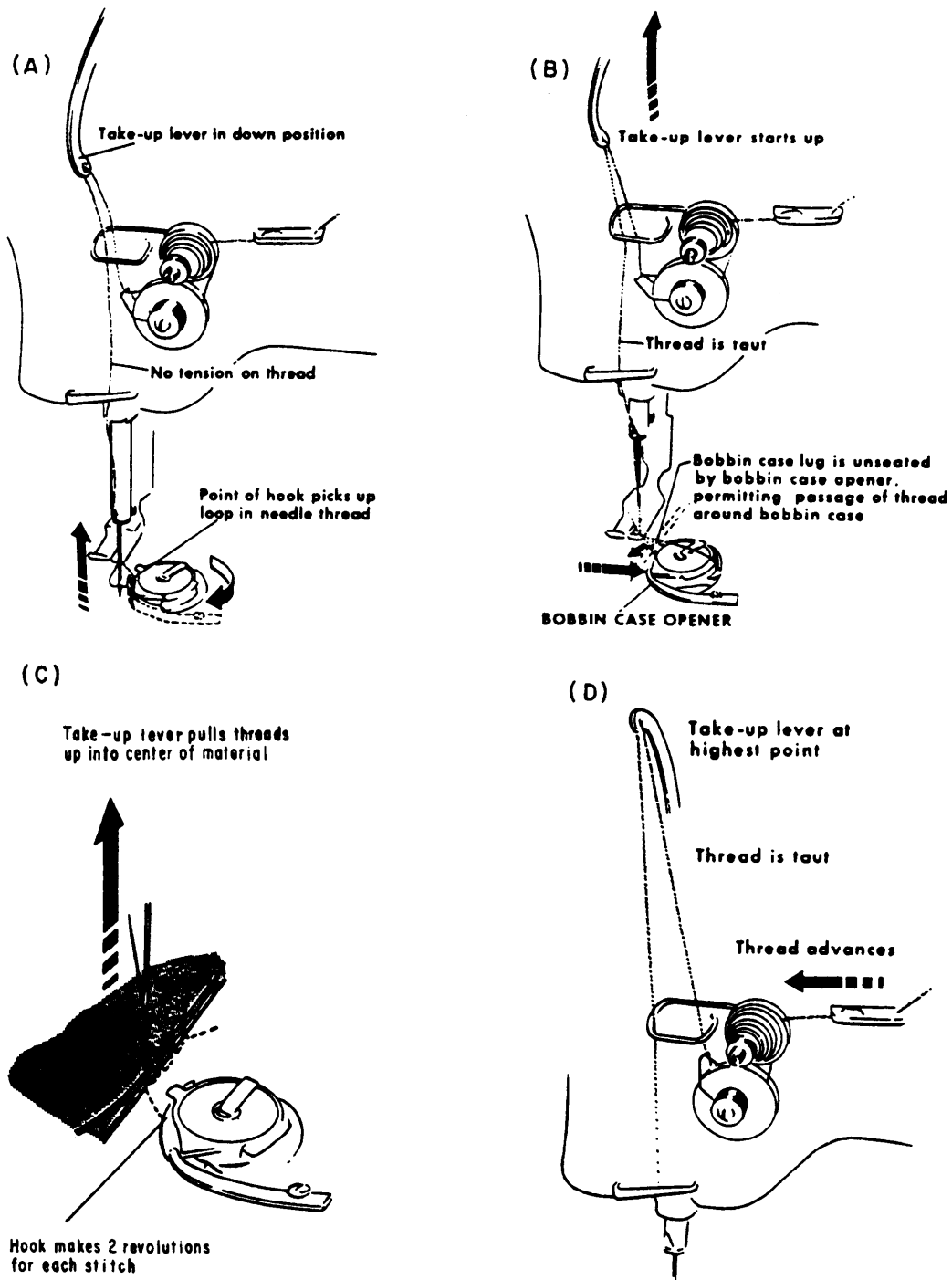

239.261

Figure 9-1.—The lockstitch.

reaches its highest position, the stitch is completed. (See views C and D of figure 9-1.)

Now look at figure 9-2. The standard sewing machine has four basic parts: bed, uprise, arm, and face. The BED (1) houses the linkage from the safety clutch pulley to the sewing hook

assembly; the UPRISE (14) houses the arm shaft connection belt; the BALANCE WHEEL (12) is connected to the arm shaft in the ARM (11), which operates the needle bar mechanism in the FACE (6) of the machine.

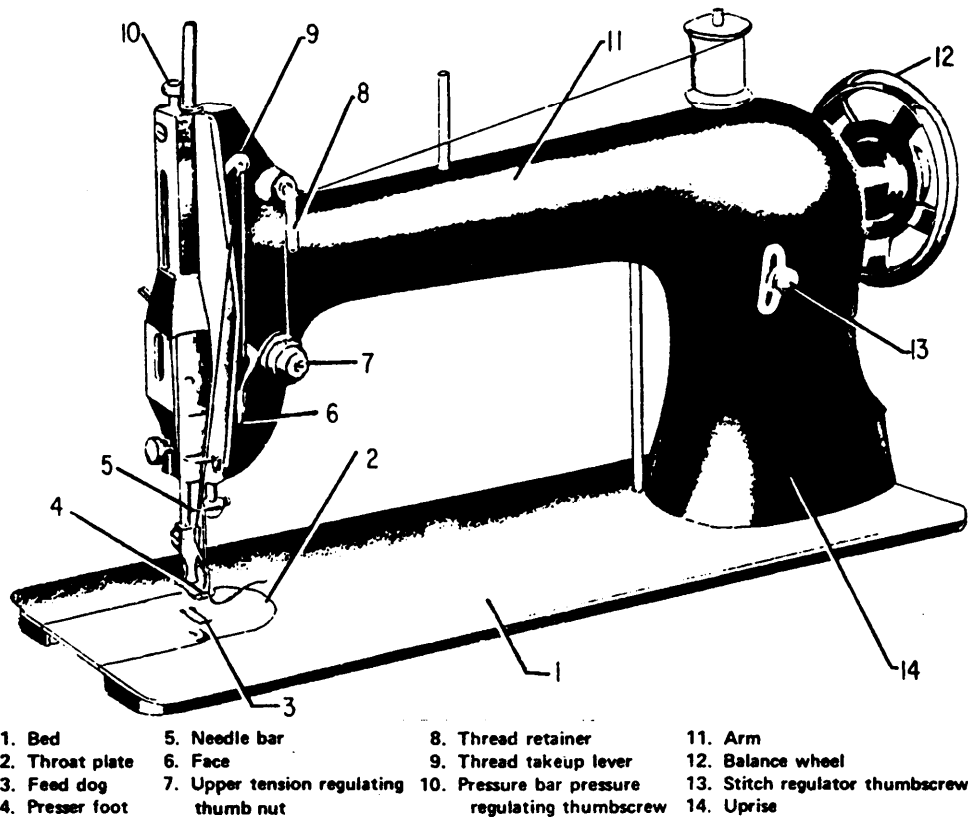

Figure 9-2.—Sewing machine 31-15.

239.262

The machine is powered by an electric motor, which is connected to the motor driving pulley by a clutch. You connect the motor to the clutch by pressing the forward part of the foot treadle. The aft part of the treadle is the brake, which acts upon the clutch.

The material to be sewn is held in position on the feed dog by the presser foot. The pressure of the presser foot upon the material enables the feed dog to push the material forward each time the needle goes up. The pressure of the presser foot on the material is released either by a knee lifter or a hand lifter. The presser foot can be raised by pushing the knee lifter to the right. The hand lifter is located behind the face of the machine. The presser foot may be lifted and locked into position by raising the hand lifter to its highest position.

OSCILLATING TYPE SEWING MACHINES

Two of the most commonly used oscillating sewing machines are the 31-15 and 7-33, both of which are discussed in this chapter.

SINGER SEWING MACHINE 31-15

When starting out as a PR, the 31-15 sewing machine will probably be the one you'll like to use. This machine is smaller and lighter than most of the other machines used in the parachute loft. The manufacturer calls the 31-15 a tailoring machine. It is used to sew and repair clothing, uniforms, shirts, flying clothing, jackets, and lightweight protective covers.

The 31-15 is an oscillating sewing machine that has a recommended speed of 2,200 stitches per minute and makes a lockstitch. It is very good for sewing nylon cloth, and can be used for sewing lightweight canvas up to 8 ounces. The number of stitches can be regulated from 7 to 32 stitches per inch.

When the 31-15 machine is in operation, the balance wheel turns over toward the operator. When hand-turning the balance wheel, always rotate it in this direction. The components of the Singer Sewing Machine 31-15 are shown in figure 9-2.

The following practices and procedures help to ensure safe and smooth operation of the sewing machine:

1. The balance wheel must always turn toward the operator.
2. Do not run the machine with the presser foot resting on the feed dog without material being under the presser foot.
3. Do not run the machine when both bobbin case and needle are threaded unless there is material under the presser foot.
4. Do not try to help the machine by pulling the material. You may bend or break the needle. If properly adjusted, the machine feeds the work without assistance.
5. The slide over the bobbin case should be kept closed when the machine is in operation.
6. Keep your head away from the thread take-up lever and needle bar at the top of the sewing machine face.
7. When running the machine, do not take your eyes away from the needle and presser foot.
8. Keep your fingers from under the needle.
9. When running the machine, keep your fingers away from the belt and pulley areas.

10. Never attempt threading the needle when the machine is turned on.

Lubrication

To ensure easy operation and to prevent unnecessary wear of the moving parts, all sewing machines need oiling. When a machine is in constant use, it should be oiled twice a day. A new machine should be oiled more frequently when in constant use. Use only one drop of oil at each oiling point. A 10W mineral oil is recommended.

Oiling points for the 31-15 machine are shown in figures 9-3, 9-4, and 9-5. Oil should be applied regularly to the shuttle bearing in the shuttle race. Occasionally, remove the faceplate and apply oil to the bearings and points that are uncovered.

Timing the 31-15

There are two distinct timing operations for the 31-15 machine. One operation times the needle with the shuttle; the other timing operation times the feed dog with the needle. Both the needle with the shuttle and the feed dog with the needle must

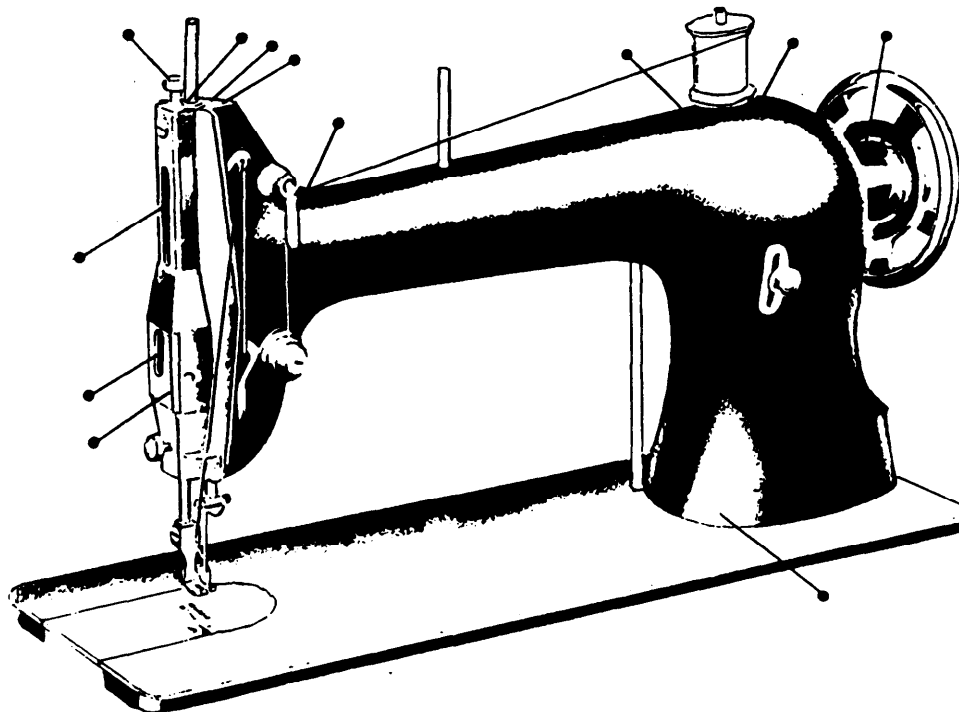
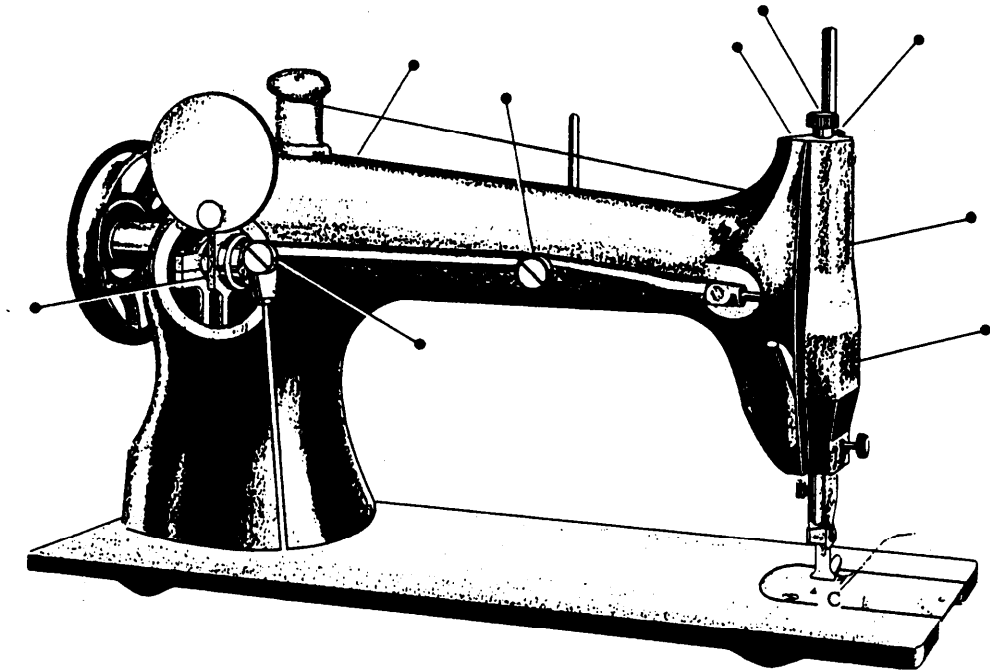

Figure 9-3.—Oiling points at the front of the machine.

239.263



239.264

Figure 9-4.—Oiling points at the back of the machine.

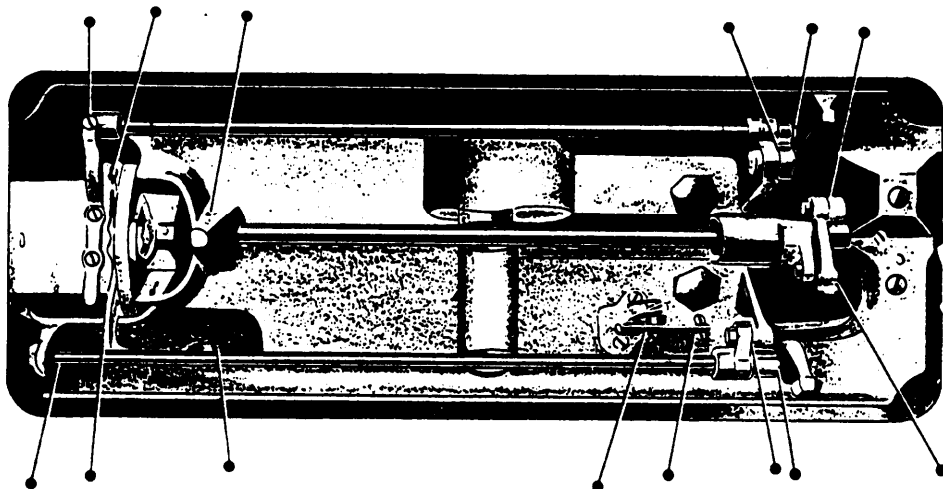

239.265

Figure 9-5.—Oiling points at the base of the machine.

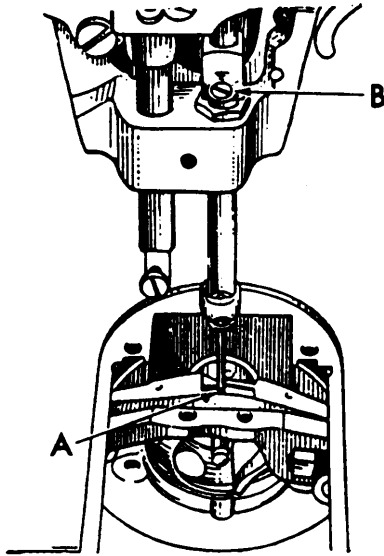

239.443

Figure 9-6.—Timing needle with shuttle.

be in proper time for the machine to function properly. See figure 9-6.

Timing the Needle with the Shuttle

If a class 31 sewing machine does not form the lockstitch, if it skips stitches, or if it frays or breaks thread, the needle is not moving in the proper relationship with the shuttle's motion. First make sure you have the right needle. Check the needle for the correct class, variety 16 x 87, and size. Insert the needle in the needle bar (long groove to the left) as far as it will go (fig. 9-6). Next compare the needle stroke to the shuttle stroke. To do this, remove the throat plate. Turn the balance wheel toward you until the point of the shuttle on its forward stroke reaches the center of the needle while the needle is on the upstroke. At this time, the needle bar should have risen 1/10 inch and the point of the shuttle should be 1/16 inch above the eye of the needle, as shown in A of figure 9-6.

NOTE: Prior to making adjustments to the sewing machine, always follow the troubleshooting chart in Table 9-1.

If the needle eye is not in this position, the following steps should be taken:

1. Loosen the needle bar connecting stud screw, as shown in B of figure 9-6.

2. Move the needle bar up or down as required; and then tighten the screw.

3. Rotate the balance wheel through the full cycle to check the timing.

4. Replace the throat plate.

Timing the Feed Dog with the Needle

The feed driving eccentric is an adjustable connection between the arm shaft (the shaft in the head) and the feed rock shaft (first shaft beneath the bed of the machine). If the feed mechanism is properly timed, the feed dog should be on its downstroke and level with the throat plate when the point of the needle reaches the material. If there is a twisted knot every 1 to 2 inches on the bottom of your material, check the timing of the needle before adjusting the feed mechanism.

To adjust the feed eccentric, first lower the stitch regulator to the lowest position so the machine forms its longest stitch. Turn the balance wheel until the feed dog is on its downstroke and is flush with the throat plate. Move to the rear of the machine and take off the arm side cover. Turn the balance wheel away from you until the feed eccentric collar setscrew is visible (fig. 9-7). Hold the collar with your left thumb. Loosen the screw and rotate the balance wheel away from you until the needle, on its downstroke, reaches the material. Tighten the setscrew. Rotate the balance wheel to check the timing. Recheck the timing of the shuttle point with the needle. When you time the feeding mechanism, you may throw the needle out of time with the shuttle.

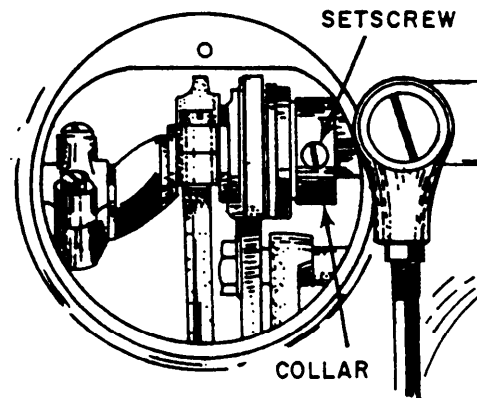

239.444

Figure 9-7.—Feed eccentric.

Table 9-1.—Troubleshooting Chart

TROUBLE	PROBABLE CAUSE	REMEDY
Needle breakage.	<p>Incorrect class and variety needle being used.</p> <p>Needle loose in clamp.</p> <p>Needle too small for fabric.</p> <p>operator pulling on the material.</p>	<p>Use correct class and variety needle.</p> <p>Tighten needle clamp screw.</p> <p>Use larger needle.</p> <p>Allow machine to feed material.</p>
Needle thread breakage.	<p>Thread too heavy for needle.</p> <p>Right twist thread being used.</p> <p>Damp or defective thread being used.</p> <p>Machine incorrectly threaded.</p> <p>Needle incorrectly set.</p> <p>Needle thread tension too tight.</p> <p>Thread take-up spring out of adjustment.</p> <p>Burr on bobbin case, Shuttle point or tension disks.</p> <p>Thread rubbing against presser foot.</p> <p>Needle has burr on eye or point, blunted or bent.</p>	<p>Use larger needle or smaller thread.</p> <p>Use left twist thread.</p> <p>Use only dry smooth thread.</p> <p>Check machine for proper threading.</p> <p>Set needle with long groove to the left.</p> <p>Loosen needle thread tension.</p> <p>Adjust thread take-up spring.</p> <p>Smooth with emery cloth.</p> <p>Adjust presser foot.</p> <p>Replace needle.</p>
Bobbin thread breakage.	<p>Bobbin tension too tight.</p> <p>Bobbin incorrectly threaded.</p> <p>Bobbin wound too full to revolve freely.</p> <p>Rounds of bobbin thread lapped over one another.</p> <p>Bobbin case is dirty.</p>	<p>Adjust bobbin tension.</p> <p>Thread bobbin to revolve clockwise.</p> <p>Remove some of the bobbin thread.</p> <p>Insure bobbin thread is straight when winding bobbin.</p> <p>Clean and lubricate bobbin case.</p>
Skipped stitches.	<p>Machine out of time.</p> <p>Thread controller spring out of adjustment.</p>	<p>Time needle to shuttle.</p> <p>Adjust thread controller spring.</p>
Drawing of seam.	<p>Needle and bobbin tension too tight.</p>	<p>Loosen needle and bobbin tension.</p>
stitches piled up.	<p>Stitch regulator out of adjustment.</p> <p>Pressure on presser foot too tight.</p>	<p>Adjust stitch regulator.</p> <p>Loosen presser foot adjustment screw.</p>
Feed dog striking throat plate.	<p>Feed dog set too high.</p>	<p>Lower feed dog to correct height.</p>

Adjusting the Feed Dog

The height at which the feed dog should be set depends on the weight and number of plies of the material being sewn. If the feed dog is set too low, the material does not feed through the machine; if it is set too high, it may cut or fray the material. The recommended height of the feed dog for sewing lightweight canopy material is slightly less than one tooth above the throat plate. If you are sewing heavier material, raise the feed dog to a height that ensures positive feeding of the material. After you have decided on the correct height for the project you are working on, adjust the feed dog accordingly, by loosening and then tightening the screw, as shown in figure 9-7. You must remember that each time the height of the feed dog is changed, the feeding mechanism may be out of time. For this reason, set the feed dog first, and then make the necessary adjustment on the feeding mechanism. Since most of your canopy repairs involve material of approximately the same weight, one-time adjustment of the feed dog is usually sufficient. Repeated changing of its height is not necessary.

Adjusting the Thread Take-up Spring

To adjust correctly the take-up spring in the tension assembly (fig. 9-8), you should first understand its normal operation. The thread take-up lever pulls the thread take-up spring down about even with the slack thread regulator while the needle is going up. While the take-up lever is coming down with the needle, the thread take-up spring pulls the slack out of the thread and keeps it from getting under the needle. If you do not have this adjusted properly, a loop can form

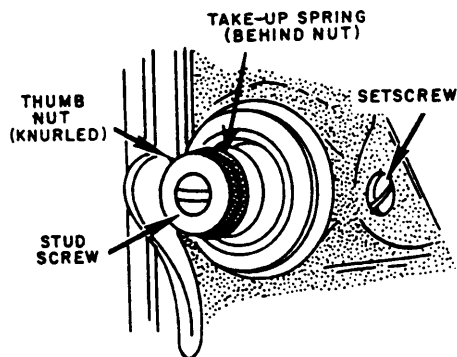

Figure 9-8.—Tension assembly.

over the needle hole in the throat plate, and the needle can split the thread as it enters the needle hole. You should set the spring about 1/4 inch above the slack thread regulator. The thread take-up spring should be set so that the spring will have completed its downward motion and be resting on the stop when the needle, on its downstroke, reaches the fabric.

To adjust the spring, loosen the setscrew, as shown in figure 9-8. To put more tension on the spring, you turn the assembly clockwise; to put less tension on the spring, you turn the assembly counterclockwise.

It may be necessary for you to replace the thread take-up spring because it can bend and become weak. Loosen the setscrew and insert a screwdriver into the slot of the tension screw stud (fig. 9-8). Turn the stud to the left until it is screwed out of the thread take-up spring regulator.

Remove thumb nut (fig. 9-8), the tension spring, and tension discs. The take-up spring is now free for removal. After replacing the old spring with a new one, assemble the parts in reverse procedure.

Replacing the Needle

While replacing a needle is a relatively simple job, you must know a few things about needles in order to decide which needle is required when a needle must be replaced. It is very important that the proper needle be used to ensure good machine operation. The selection of needles by class, variety, and size for different machines and materials is necessary to eliminate thread breakage, needle breakage, skipped stitches, and fraying of the thread.

Needles for the various machine classes are selected and ordered by needle number and size. The needle numbers consist of a class number and variety number separated by a "x"; for example, the class and variety needle 16 x 87 is used in the 31-15 sewing machine. Cloth point needles are round, sharp-pointed needles used for sewing cloth, since they do not cut the strands as they are forced between the woven threads of the fabric. Many different varieties of cutting point needles are available, but they are used only for sewing heavy leather. Figure 9-9 shows the shape of the openings made in material by the cloth point (view A), twist point (view B), and the diamond point (view C). Figure 9-9 illustrates why it is important that a round-pointed needle be used in cloth; views B and C show how cutting point needles can cut the warp and filler threads.

239.445

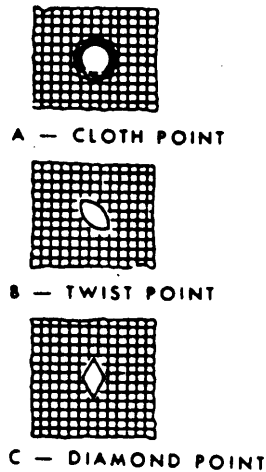

239.446
 Figure 9-9.—Shapes of needle points.

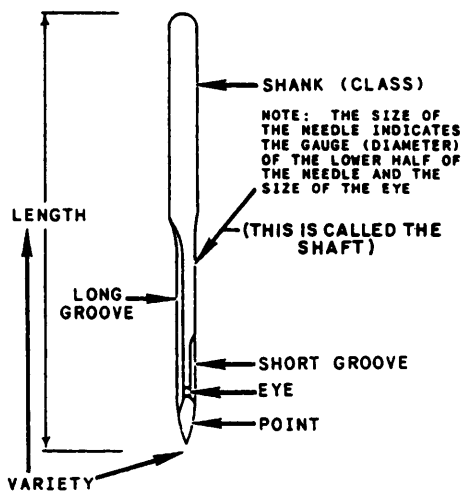

239.447
 Figure 9-10.—Sewing machine needle.

Machine needles have long groove on one side, and either a short groove or a scarf on the opposite side, as shown in figure 9-10. The purpose of the grooves is to allow the thread to fall back into the needle when it enters the material to prevent the thread from breaking or fraying; therefore, it is important that the long groove be placed in the machine properly. On different class machines, the direction varies with the position of the bobbin assemblies. On class 31 machines, the long groove is placed to the left. The scarf is to prevent the oscillating shuttle from striking the needle as it passes close to the needle to pick up the thread loop to form the lockstitch.

Needles are sized by the diameter or gauge of the needle and the needle eye. The selection of the correct size needle is determined by the size and type of thread and material used. The thread must pass freely through the eye of the needle to prevent thread fraying or breaking. The sizes of the class 16 x 87 needles used for most sewing will range from size 18 through size 22. The needle size number increases with the diameter of the needle; therefore size 18 needles are used for lighter weight materials than size 22. Listed below are some of the needle sizes you will be working with and their uses:

1. Size 18. For sewing two to four plies of thin material, such as silk, nylon, or rayon, with size E thread.
2. Size 20. For sewing five or more plies.
3. Size 21. For sewing two to four plies of medium weight materials, such as aircraft cloth, 12-ounce duck, light leather, and artificial leather.
4. Size 22. For sewing two to four plies of medium weight material, such as heavy duck, lightweight and medium weight webbings, and russet leather.
5. Size 24. For sewing elastic or rubberized materials.

You should check the condition of the needle's point before you start to sew. A dull or rough round needle acts the same as a cutting needle. It cuts or pulls threads and may weaken the seam. The condition of a needle may be checked by sliding the fingernail over the point. If it scratches or catches the nail, the needle should be replaced with a new one. A dull needle may be sharpened by placing it in the chuck of a drill press, and the drill operated at high speed while holding a fine grain sharpening stone lightly against the side of the needle at the proper angle. The point is then polished with a piece of russet leather.

Having selected the proper needle, turn the balance wheel toward you until the needle bar moves to its highest point. Loosen the needle clamp screw and put the shank of the needle up into the groove as far as it will go. Turn the long groove so that it faces to the left and is directly in line with the arm of the machine. Then tighten the clamp screw, and check to see that the needle does not turn or slip. For troubleshooting, refer to table 9-1.

Threading the Machine

Threading a machine is a very simple job. The procedure may vary slightly with different models; but after working with the various machines in the loft, the task becomes automatic.

The component parts used in threading the 31-15 sewing machine are shown in figure 9-11. Use this figure in studying the procedures that follow. Pass the thread from the thread stand to the thread post on top of the machine, right to left through the bottom hole, and then right to left

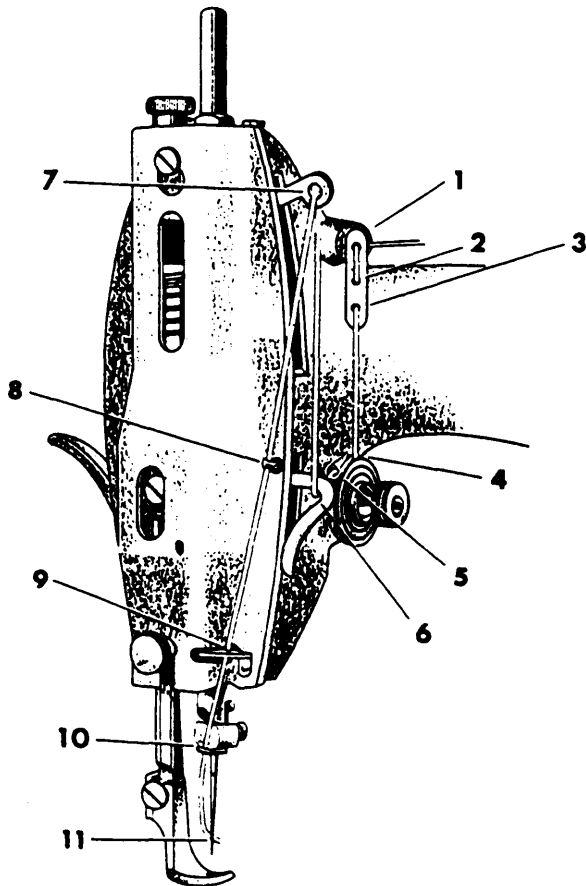

1. Top hole of thread retainer
2. Middle hole of thread retainer
3. Bottom hole of thread retainer
4. Tension disks
5. Thread takeup spring
6. Tension thread guard
7. Thread takeup lever
8. Thread guide
9. Thread guide
10. Thread guide
11. Needle eye

239.268

Figure 9-11.—Threading the 31-15 sewing machine.

through the top hole. Pass the thread from right to left through the top hole in the thread retainer (1). Pass the thread from left to right through the middle hole in the thread retainer (2). Pass the thread from right to left through the bottom hole in the thread retainer (3). The thread is then passed down and under from right to left between the tension disks (4). Draw the thread up into the thread take-up spring (5), drawing the thread up and beyond the spring end so that it comes out in the center of the spring. The thread is then placed under the tension thread guard (6). Pass the thread up and from right to left through the hole in the thread take-up lever (7). The thread is now drawn down through three thread guides (8), (9), and (10). Pass the thread from left to right through the eye of the needle (11). Draw about 2 inches of thread through the eye of the needle to begin sewing.

Removing the Bobbin Case

Before attempting to remove the bobbin case, turn the balance wheel toward you until the needle moves upward to its highest position.

Remove the slide in the bed of the machine so you can see what you are doing. Reach under the table with your left hand, and, using your thumb and forefinger, open the bobbin case latch (fig. 9-12) and lift out the bobbin case.

While the latch is held open, the bobbin is retained in the bobbin case. Release the latch, turn the open end of the bobbin case down, and the bobbin will drop out.

Winding the Bobbin

The bobbin winder is fastened to the table with its driving pulley in front of the sewing machine

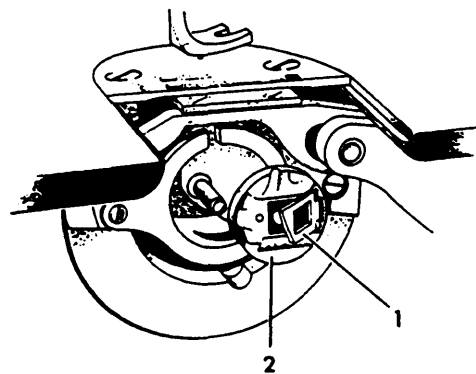

1. Bobbin case latch
2. Bobbin case

239.269

Figure 9-12.—Removing bobbin case.

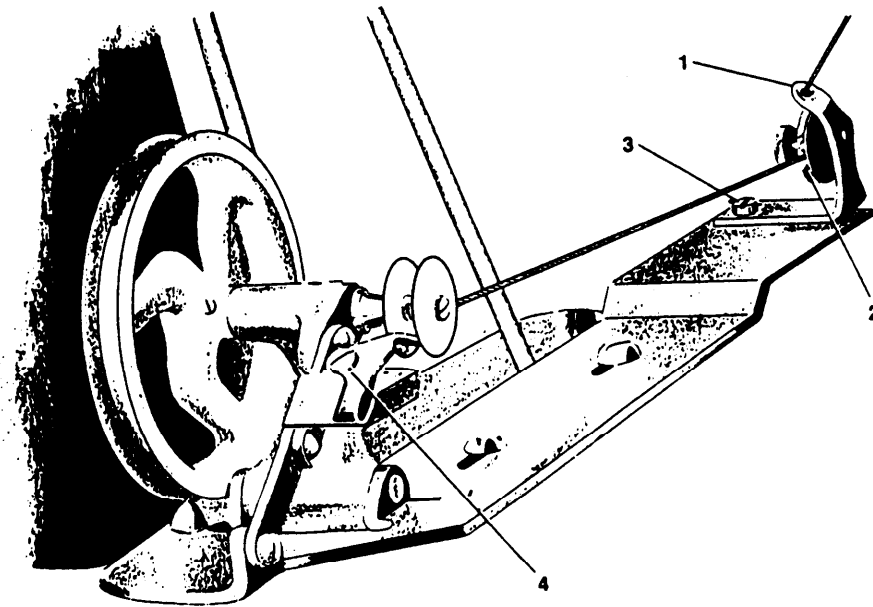

- | | |
|-----------------|-----------------------------------|
| 1. Thread guide | 3. Setscrew |
| 2. Tension disk | 4. Bobbin winder stop latch screw |

239.270

Figure 9-13.—Winding the bobbin.

belt. The bobbin winder is so positioned to allow the pulley to drop away from the belt when sufficient thread has been wound on the bobbin.

Figure 9-13 illustrates the bobbin-winding operation. The procedure is as follows: Place the bobbin on the bobbin winder and push it on the shaft as far as it will go. Pass the thread from the spool down through the thread guide. Loop the thread around back and through the tension disks.

The thread is then wound around the bobbin a few times and the pulley pushed up against the machine belt. The bobbin can be wound while the machine is being used for sewing. If there is no material under the presser foot, make certain that the presser foot is raised and not riding on the feed dog while winding the bobbin.

When sufficient thread has been wound on the bobbin, the pulley on the bobbin winder drops back from the machine belt automatically. If the thread does not wind evenly on the bobbin, loosen the setscrew in the tension bracket and move the bracket to the right or left as required; then tighten the bobbin winder stop latch screw. The amount of thread wound on the bobbin is regulated by the bobbin winder stop latch. To wind more thread on the bobbin, turn the screw to the right; to wind less thread on the bobbin, turn this screw to the left.

Threading the Bobbin Case

Hold the fully wound bobbin between the thumb and forefinger of the right hand with the thread end running over the top toward the right, as shown in figure 9-14, view A. With the left

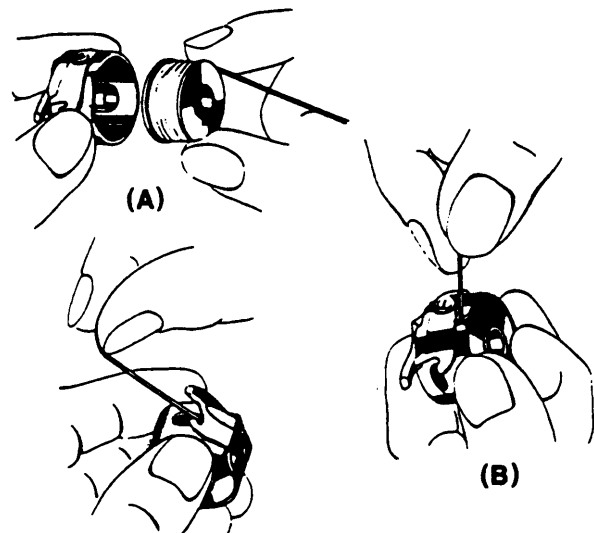

239.271

Figure 9-14.—Threading the bobbin case.

hand, hold the bobbin case as shown, with the thread slot near the top.

Place the bobbin into the bobbin case and pull the thread into the slot in the edge of the bobbin case (view B). Draw the thread down under the tension spring and into the delivery eye at the end of the tension spring (view C). When the free end of the thread is pulled, the bobbin will rotate clockwise if the bobbin case has been threaded properly.

Replacing the Bobbin Case

Hold the latch open on the threaded bobbin case with the thumb and forefinger of the left hand, with the latch in a horizontal position. Place the bobbin case on the center stud of the shuttle body. Release the latch and press the bobbin case back until the latch catches the groove near the end of the stud.

Preparing for Sewing

With the left hand, hold the end of the needle thread, leaving it slack from the hand to the needle. Turn the balance wheel toward you until the needle moves down and catches the bobbin thread. Continue to turn the balance wheel forward until the needle comes up and brings the bobbin thread up with the needle thread.

With the thread take-up lever at its highest position, lay both threads back under the presser foot .

Commencing to Sew

Place the edge of the material beneath the presser foot, lower the presser foot, turn the balance wheel by hand until the needle is in the material, and press lightly on the treadle. To prevent fouling the needle thread in the bobbin case, hold the ends of both threads until the first few stitches are made.

While sewing, hold the work flat, but do not pull or push on the material. Let the feed dog carry the work evenly under the presser foot and needle. If the operator pulls on the material, the needle bends, strikes the throat plate, and is either dulled, or more likely, broken. When the needle is about to cross a seam or other unusually thick or uneven place in the work, disengage the clutch, and hand-turn the machine over the rough place; otherwise, the needle may be broken or thrown out of time.

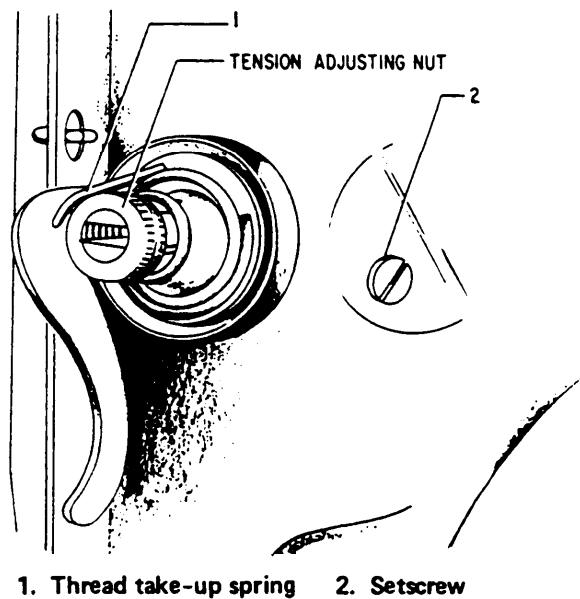

1. Thread take-up spring 2. Setscrew

239.272

Figure 9-15.—Adjusting the machine thread tension.

Regulating the Tension

The tension on the needle thread should be regulated only when the presser foot is down. If the tension of the machine thread is not correct, it should be adjusted by turning the tension adjusting nut, as shown in figure 9-15. To INCREASE THE TENSION, turn the nut clockwise; to DECREASE THE TENSION, turn the nut counterclockwise.

The tension on the bobbin thread is regulated by the small screw in the bobbin case tension spring. To increase the tension, turn the screw clockwise; to decrease the tension, turn the screw counterclockwise.

This screw is very small and is easily lost if extreme care is not exercised in backing it out when the tension is decreased. If the screw is tightened excessively or is slightly too long, it will penetrate into the inside of the bobbin case and prevent removal of the bobbin.

When the tension on the bobbin thread has been properly adjusted for a particular size of thread, it is seldom necessary to change it. A correct stitch can usually be obtained by varying the tension on the needle thread, which is an easier adjustment.

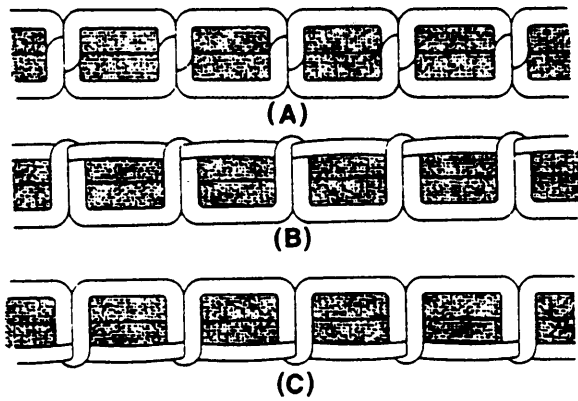

239.273

Figure 9-16.—Properly and improperly adjusted tensions.

For ordinary stitching, the needle and bobbin threads should be locked in the center of the thickness of the material, as shown in figure 9-16, view A. When adjusting the tensions, you will not have a cross section of the stitch.

If the tension on the needle thread is too tight, or if the bobbin tension is too loose, the thread will lie straight along the upper surface of the material and appear as small loops, as shown in figure 9-16, view B.

If the tension on the bobbin thread is too tight, or if tension on the needle thread is too loose, the bobbin thread will lie straight along the underside of the material, as shown in figure 9-16, view C.

Regulating the Length of a Stitch

The length of a stitch can be checked at the time the tension of the stitch is checked, as a trial run of stitches is necessary during both procedures.

The length of a stitch is regulated by the thumbscrew in the slot on the front of the uprise of the machine. To LENGTHEN the stitch, loosen the thumbscrew and move the lever DOWN. To SHORTEN the stitch, loosen the thumbscrew and move the lever UP. When the desired length of stitch has been obtained by test running the machine on scrap material, tighten the thumbscrew.

Regulating the Pressure on the Material

Pressure on the material is regulated by the pressure-regulating thumbscrew on top of the

machine face. To increase the pressure, turn the thumbscrew clockwise. The pressure should be just heavy enough to enable the feed dog to move the work along evenly.

Removing Work

Hand-turn the balance wheel toward you until the thread take-up lever is at its highest position. Raise the presser foot, either by the hand lever or by the knee lift, and draw the work and threads straight behind the presser foot. Cut the threads close to the material, leaving free about 2 inches of bobbin and machine thread.

Adjusting the Thread Take-up Spring

The thread take-up spring (fig. 9-15) should be set so that when the eye of the needle reaches the material on the downward stroke of the needle bar, the spring will be through acting on the thread, and will rest against the stop of the thread take-up spring regulator.

If the thread take-up spring is not correctly set, loosen the setscrew (2) in the arm of the machine and turn the tension adjusting stud to the right for more movement of the spring, or to the left for less movement. When the spring is correctly set, retighten the setscrew.

The tension on the thread take-up spring should be just sufficient to take up the slack of the needle thread until the eye of the needle reaches the material on its descent. To increase the tension on the thread take-up spring, loosen the tension adjusting stud and move the take-up spring from the recess in the regulator to the right between the regulator and the tension disks. When the required tension is obtained, securely tighten the tension adjusting stud and move the spring back into its position in the regulator recess. To decrease the tension, move the spring to the left between the regulator and the tension disks.

SINGER SEWING MACHINE 7-33

The class 7-33 sewing machine is a lockstitch heavy duty machine, and is intended for use in sewing heavy canvas, webbings, and other material not adaptable to the lighter duty sewing machines. The only difference between the 7-31 and the 7-33 is that the 7-33 has the clutch on the motor, while the 7-31 has the clutch on the balance wheel. The operation and maintenance techniques are identical. The procedure for operating the 7-33 sewing machine is the same as for the 31-15 sewing machine.

As on any Singer sewing machine, the balance wheel of the 7-33 should always turn toward the operator.

Lubrication

The 7-33 machine is oiled at all the oiling points shown in figures 9-17 and 9-18. The machine should be oiled twice daily when it is in

constant use. Use a castor base oil as recommended by the manufacturer.

Needles and Thread

The procedure for ordering needles is the same for the 7-33 machine as for the 31-15 sewing machine. Refer to table 9-2 for the relative sizes of needles and thread.

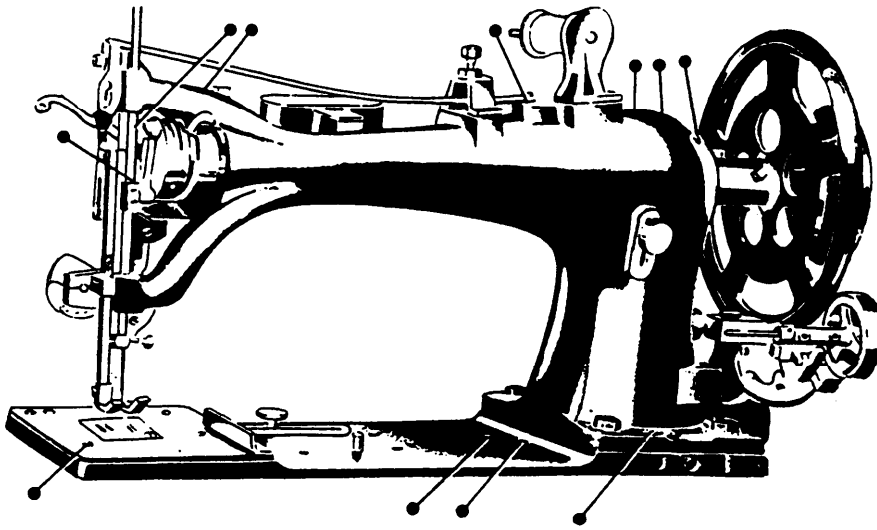

Figure 9-17.—Oiling points at the front of the 7-33 sewing machine.

239.274

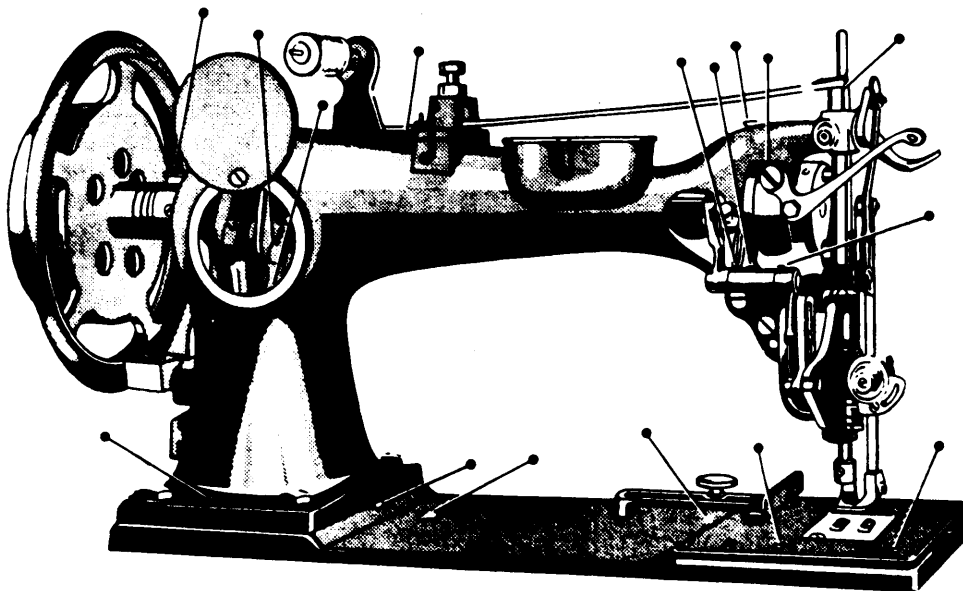

Figure 9-18.—Oiling points at the back of the 7-33 sewing machine.

239.275

Table 9-2.—Relative sizes of needles and thread

Machine	Needle class and variety	Needle sizes	Classes of work	Needle size	Cord size
7-31 or 7-33	7 x 1	19, 21, 22, 23, 24 25, 26, and 27.	Medium to heavy canvas.	24	3-cord
7-31 or 7-33	7 x 5	28, 29, 30, and 31.	Heavy canvas and webbing.	28	6-cord

Setting the Needle

The same procedure may be followed with this machine as for the 31-15 sewing machines.

Threading the Machine

Turn the balance wheel toward you until the thread take-up lever (7) moves up to its highest position (fig. 9-19). Pass the thread from the thread stand to the thread post, right to left

through the bottom hole, then right to left through the top hole. Pass the thread through the two thread guides (1) and (2). Continue the passage of thread between the retainer disks (3), down and under the tension disks (4). Pass the thread into the loop of the thread take-up spring (5), under the wire loop (6), up, and from back to front through the hole in the thread take-up lever (7). Now pass the thread down through the thread guide (8), into the slot in the vibrating presser bar (9), and on down through the thread

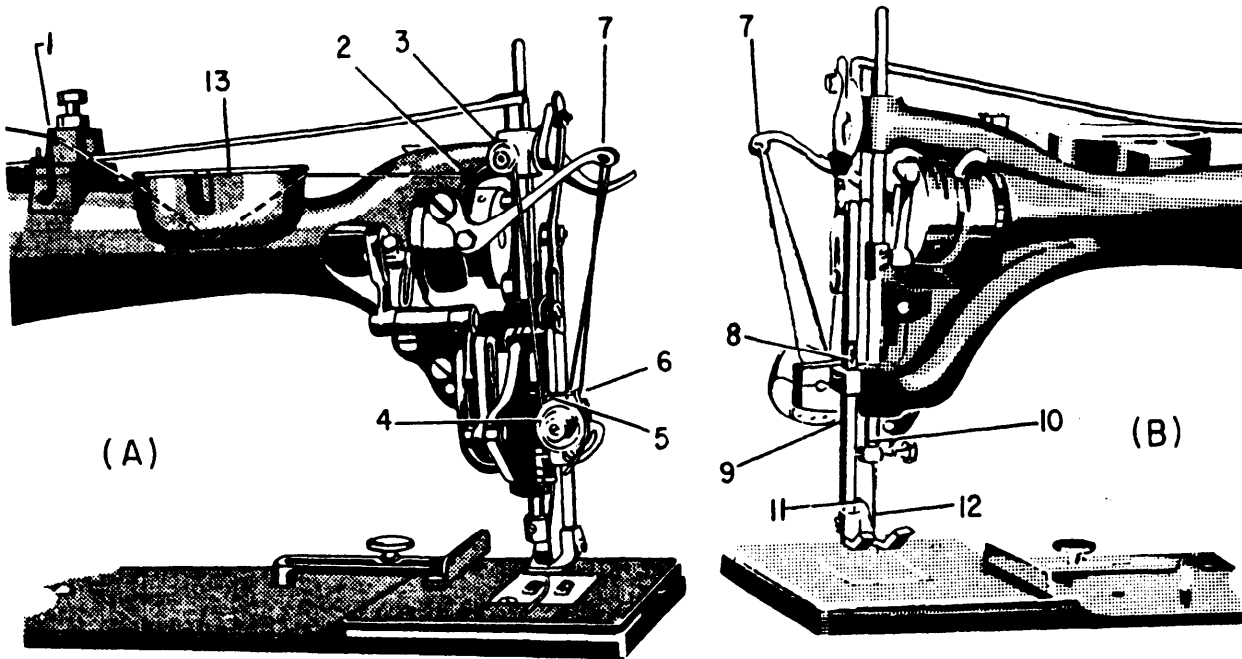

- 1. Thread guide
- 2. Thread guide
- 3. Retainer disks
- 4. Tension disks
- 5. Thread takeup spring

- 6. Wire loop.
- 7. Thread takeup lever
- 8. Thread guide
- 9. Slot in the vibrating presser bar
- 10. Thread guide on the needle clamp

- 11. Eye of the needle
- 12. Hole in the lifting presser foot
- 13. Lubricating cup

Figure 9-19.—Threading the 7-33 sewing machine.

239.276

guide (10), which is located on the needle clamp. The needle is now threaded from left to right through the eye of the needle (11). After the needle is threaded as shown in figure 9-19, pass the thread down through the hole in the lifting presser foot (12). Draw about 4 inches of thread through the hole in the lifting presser foot with which to begin sewing.

Notice that the lubricating cup has been bypassed. No lubricant is used on the threads and cords used in the manufacture or repair of parachutes.

Removing the Bobbin

Turn the balance wheel forward to bring the needle bar and thread take-up lever to its lowest position. With the aid of the shuttle opening tool or a small screwdriver, insert the blade end in the slot in the spring latch beneath the shuttle cylinder (fig. 9-20). Press the latch away from the cylinder and it will swing out. The bobbin will then slide out of the shuttle cylinder.

Winding the Bobbin

Place the bobbin on the bobbin winder spindle and push it up closely against the shoulder. The small pin in the shoulder must enter the slot in the bobbin.

Pass the thread from the thread stand through the hole in the left side of the bobbin from the inside. Push the bobbin winder pulley up against the balance wheel, and place the bobbin winder

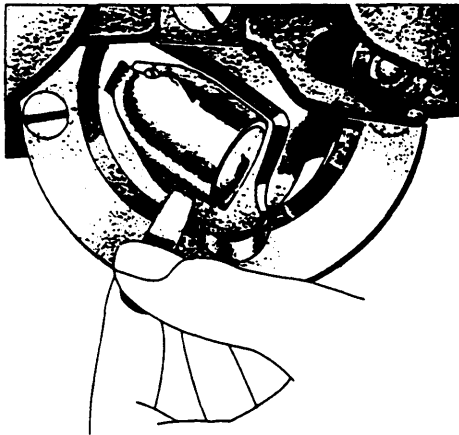

239.277

Figure 9-20.—Removing the bobbin from the shuttle cylinder.

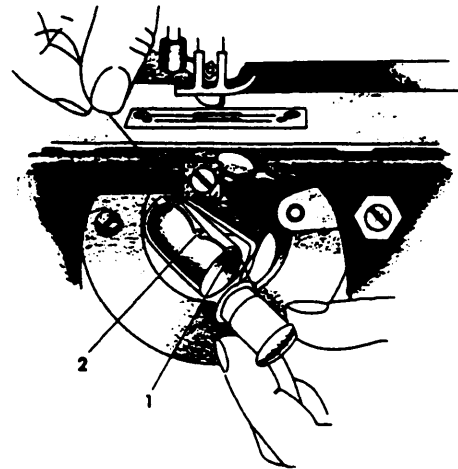

1. Thread slot in the cylinder
2. Delivery eye and tension spring

239.278

Figure 9-21.—Replacing the bobbin.

latch in position. Raise the presser foot and start the machine. The end of the thread should be held until a few turns are wound on the bobbin to prevent slipping. When sufficient thread has been wound on the bobbin, the bobbin winder will stop automatically.

Replacing the Bobbin and Threading the Shuttle

Take the bobbin between the thumb and forefinger of the left hand, as shown in figure 9-21. The free end of the thread should be drawn off from the underside toward the right. Place the bobbin in the shuttle cylinder as far as it will go. Draw the thread into the slot in the cylinder and under the tension spring into the delivery eye. Push the shuttle cylinder in until it is locked by the spring latch. There should be about 3 inches of thread hanging free from the shuttle with which to begin sewing.

Regulating the Tension

The tension on the needle thread is regulated by the thumb nut at the front of the thread retainer disks. The tension on the thread retainer disks should be just enough to cause the tension wheel to turn when the thread is taken from the spool.

The tension on the bobbin thread is regulated by the small screw that holds the tension spring to the shuttle cylinder. To increase the tension,

turn the screw clockwise. To decrease the tension, turn the screw counterclockwise.

The tension on the machine and bobbin threads should be checked by test-running a row of stitches on scrap material. The lockstitch should lock in the center of the material, as described for the 31-15. When sewing webbings with the 7-33 sewing machine, the specifications for webbing sewing should be checked to determine at what ply of the webbing the stitch should lock.

Regulating the Length of Stitch

The procedure for regulating the stitch on the 7-33 sewing machine is the same as for the 31-15.

Regulating the Pressure on the Material

The pressure on the material is regulated by means of the hexagon head screw (1). (See figure 9-22.) Loosen the hexagon head locknut (2) and turn the adjusting screw clockwise to increase the pressure, or counterclockwise to decrease the pressure on the spring (3). When the desired pressure has been obtained, hold the adjusting screw with a wrench to keep it from turning while

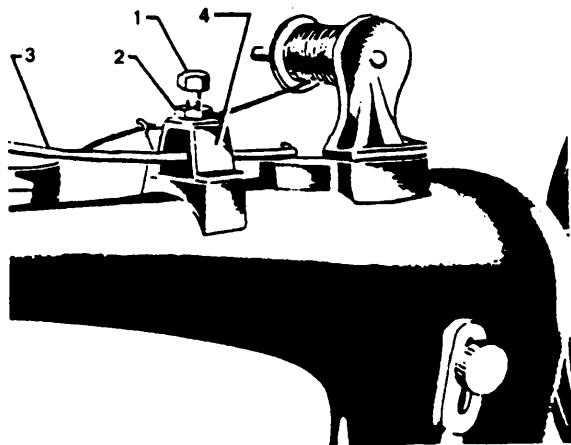

- | | |
|---------------------------------|------------|
| 1. Hexagon head adjusting screw | 3. Spring |
| 2. Hexagon head locknut | 4. Bracket |

239.279

Figure 9-22.—Regulating the pressure on the material.

the locknut is being tightened against the bracket (4).

The pressure should be just heavy enough to enable the feed dog to move the work along evenly, and to prevent the work from rising with the needle.

Preparing the Sewing

The same sewing preparatory procedures are used for the 7-33 as for the 31-15 sewing machine, except there is no knee lifting device. The hand presser bar lifter is the only device provided for lifting the presser foot on the class 7-33 sewing machine.

Removing the Work

Stop the machine and raise the thread take-up lever to its highest position. Draw about 3 inches of thread through the thread retaining disks. Raise the presser foot and draw the work back, cutting the threads close to the material. Leave the ends of the threads under the presser foot .

Modification of Presser Foot for Webbing Sewing

The modification of a presser foot is illustrated in figure 9-23. The presser foot should be cut

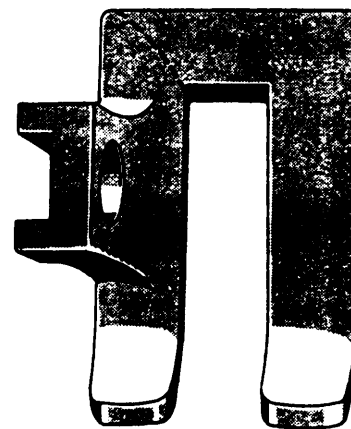

239.280

Figure 9-23.—Modification of presser foot for webbing sewing.

along the dotted line, removing the right portion of the foot. After cutting, the edges should be filed down to a smooth round finish.

Parachute harness and webbing sewing is classified as a major repair. However, there are various other sewing projects requiring webbing sewing.

ROTARY SEWING MACHINES

Some of the most commonly used rotary sewing machines are the class 111 W series. They are the type used to teach basic sewing in PR "A" school, and can be found in almost any PR shop.

CLASS 111 SEWING MACHINES

The class 111 sewing machines are one line (single needle) lockstitch machines designed to sew

medium weight and heavyweight material. They are capable of sewing at a speed of approximately 3,000 stitches per minute (spin). The lockstitch is formed in the bobbin assembly by the rotary hook on the 111 machines. The class 111 machine is commonly used for sewing aircraft protective covers, upholstery, and soundproofing.

DIFFERENT MODELS OF THE 111 W SEWING MACHINE

The following text discusses the various models of the 111 W sewing machine.

111 W 150 Sewing Machine

The 111 W 150 sewing machine is a high-speed, single-needle, lockstitch, compound feed machine employing a gear-driven rotary hook with a vertical axis. It is designed for sewing medium weight fabrics such as

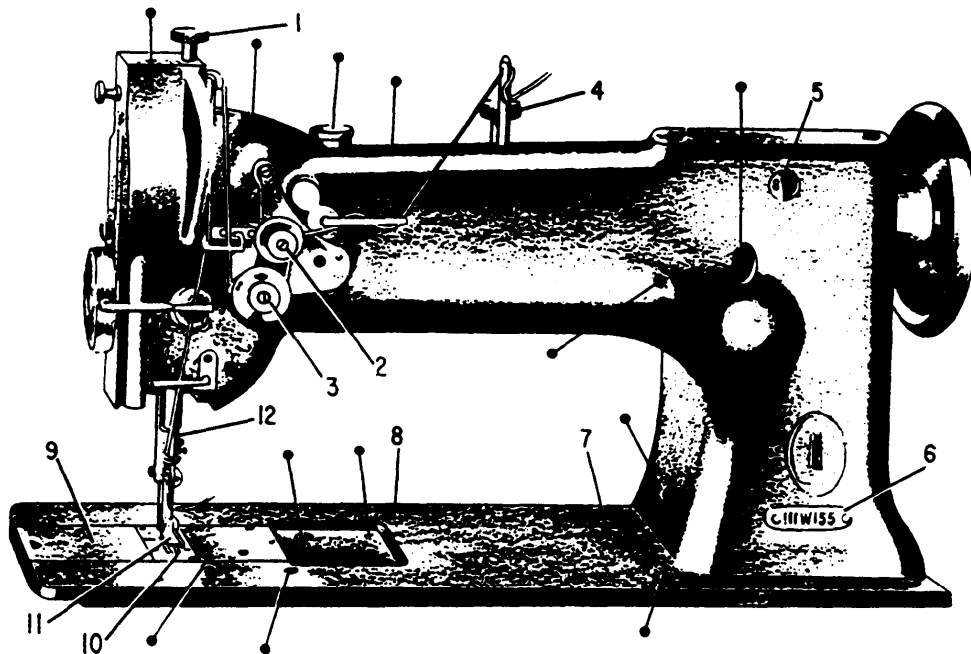

- | | |
|--|-----------------------------------|
| 1. Vibrating presser bar thumbscrew | 7. Hook driving shaft lock stud |
| 2. Tension thumb nut | 8. Feed regulating stud (plunger) |
| 3. Thread controller stud thumb nut | 9. Bed slide |
| 4. Presser bar spring regulating screw | 10. Throat plate |
| 5. Stitch indicator disk view hole | 11. Presser foot |
| 6. Model number | 12. Needle bar |

Figure 9-24A.—Class 111 sewing machine, front view showing oiling points.

239.281

flight clothing, nylon, twills, and lightweight canvas.

111 W 151 Sewing Machine

The 111 W 151 sewing machine is also a single-needle, lockstitch, rotary hook machine, intended for high-speed straight stitching of medium heavy materials.

The 111 W 151 sewing machine differs from other models of the class 111 machines in that it has a single presser foot instead of the alternating presser foot.

111 W 152 Sewing Machine

The 111 W 152 sewing machine is a single-needle, lockstitch, compound feed machine with a vertical axis sewing hook. This machine has alternating pressers with a 3/8-inch lift. It has a safety clutch that prevents the hook from being damaged or getting out of time due to accidental strain.

111 W 153 Sewing Machine

The 111 W 153 sewing machine is similar to the 111 W 152, but it is used for sewing heavy work such as automobile and truck upholstery, tents, awnings, and leather flight jackets.

111 W 154 Sewing Machine

The 111 W 154 sewing machine is also similar to the 111 W 152, but its alternating pressers have a lift of 1/2 inch, and the machine is designed for stitching upholstery work, leather coats, and binding heavy materials such as felt padding.

111 W 155 Sewing Machine

The 111 W 155 sewing machine is similar to the 111 W 154 except that its minimum stitches per inch is 3 1/2, and it has an adjustable lifting eccentric for instantly setting the alternating pressers to the minimum amount of lift required for the work to be sewn.

FUNCTIONAL FEATURES

The oiling parts for class 111 sewing machine are shown in figure 9-24A. Figure 9-24B identifies

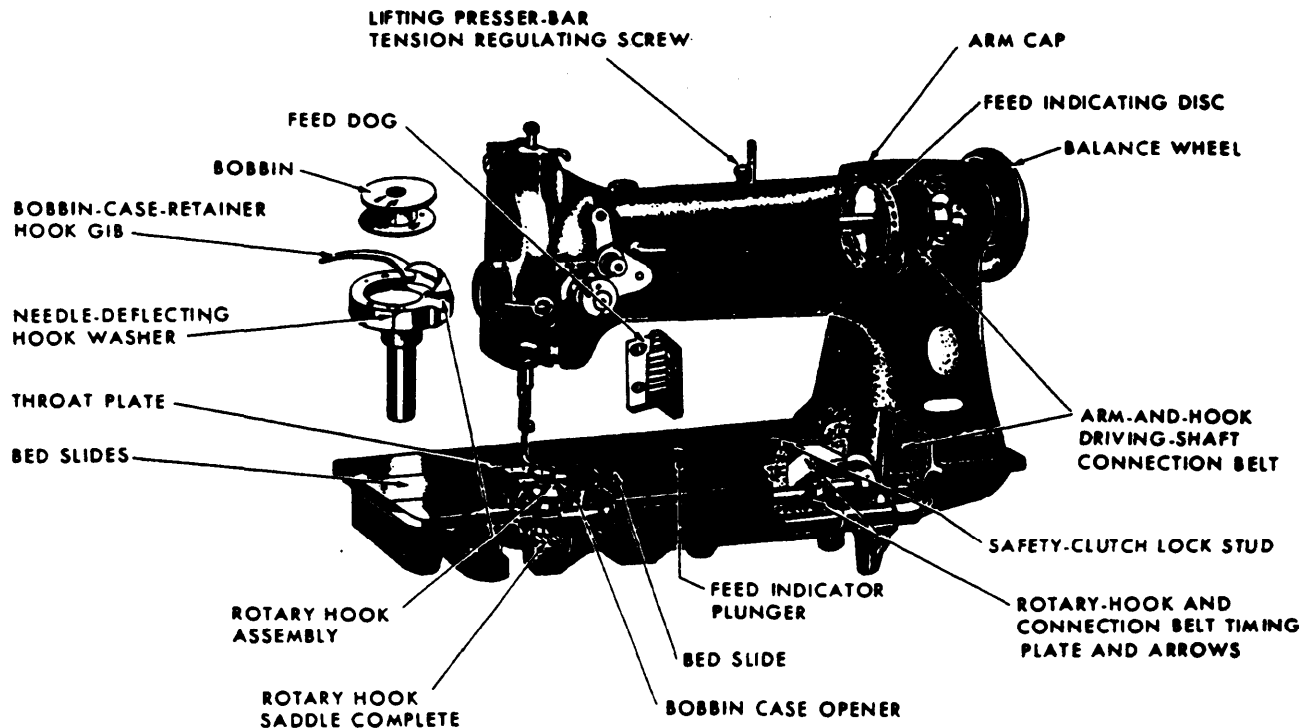

239.448

Figure 9-24B.—Class 111 sewing machine, front view showing components and parts.

the component parts. The primary feature of each component is explained in the following text:

- **Lifting Presser Bar Tension Regulating Screw.** Regulates the pressure on the alternating presser foot.

- **Feed Indicating Disc.** Indicates the number of stitches per inch which are being made by the machine.

- **Balance Wheel.** Provides a connection between the driving unit and the sewing machine head.

- **Arm-and-Hook Driving Shaft Connection Belt.** Connects the upper arm shaft with the hook driving shaft.

- **Feed Dog.** Feeds the material from the under side.

- **Rotary Hook Assembly.** Contains the mechanism that forms the lockstitch by using the needle and bobbin threads.

- **Bobbin.** Contains the lower thread used in forming the lockstitch.

- **Bobbin Case Retainer Hook Gib.** Holds the bobbin case in the bobbin race.

- **Needle-deflecting Hook Washer.** Deflects the needle so the rotary hook will not strike the needle.

- **Throat Plate.** Surrounds the feed dog and keeps the material from slipping after the feed dog has been adjusted to the proper height.

- **Bed Slides.** Covers the feed eccentric and rotary hook assembly on each side of the throat plate.

- **Feed Indicator Plunger.** Used in connection with the feed indicator to regulate the number of stitches per inch desired.

- **Safety-clutch Lock Stud.** Re-engages the needle with the hook driving assembly after clearing a thread jam.

- **Bobbin Case Opener.** Prevents thread from jamming underneath the throat plate on the bobbin case base.

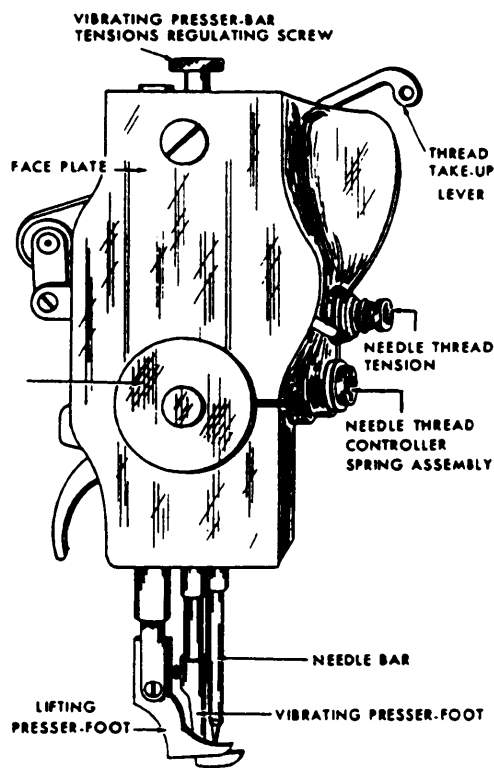

239.449

Figure 9-25A.—Class 111 sewing machine, side view.

- **Rotary Hook Saddle Complete.** The rotary hook is operated by the spiral driving pinion gear, which, in turn, is operated by the hook driving gear located on the hook driving shaft.

- **Rotary Hook and Connection Belt Timing Plate and Arrows.** Used to time the arm shaft with the hook driving shaft.

The following parts are shown in the side view of the Class 111 sewing machine (figures 9-25A and 9-25 B).

- **Thread Take-up Lever.** Pulls the needle thread against the tension disc after the lockstitch is formed at the rotary hook and pulls sufficient thread from the spool to make the next stitch.

- **Vibrating Presser Bar Tension Regulating Screw.** Regulates the pressure on the presser foot. Only sufficient pressure to hold the material securely is needed.

- **Face Plate.** Covers and protects the mechanism of the two presser feet and needle bar.

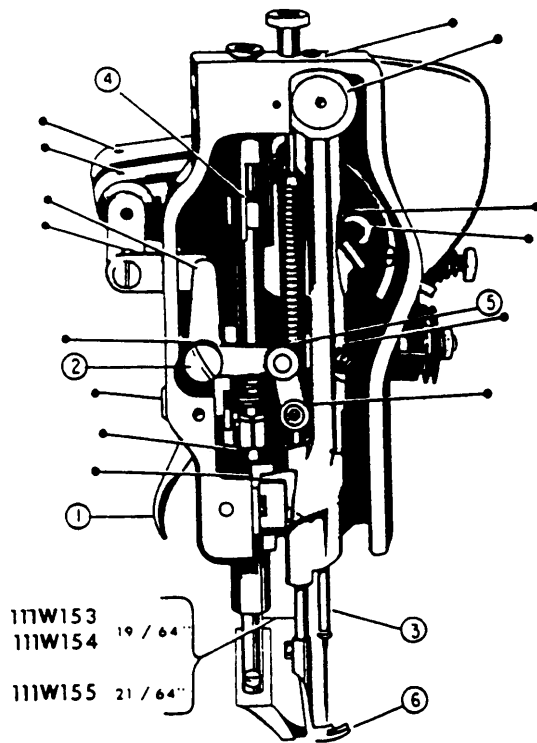

1. Hand lift for presser foot
2. Vibrating presser bar thumbscrew
3. Needle bar
4. Vibrating presser bar
5. Presser bar
6. Presser foot

239.282

Figure 9-25B.—Class 111 sewing machine, side view showing oiling points.

● **Needle Thread Lubricator.** Lubrication of the thread when sewing leather. Lubrication of the thread prevents it from fraying, and prevents the needle from becoming hot when sewing at high speed.

● **Needle Thread Tension.** Regulates the tension on the needle thread so that the lockstitch may be adjusted properly.

● **Needle Thread Controller Spring Assembly.** Removes sufficient slack from the needle thread when the needle is descending to prevent the needle from splitting the thread.

● **Needle Bar.** Holds the needle and carries the thread to the rotary hook where the lockstitch is formed.

● **Vibrating Presser Foot.** Holds the material in place while the alternating presser foot rises to make another stitch.

● **Lifting Presser Foot.** Holds the material in place while the vibrating presser foot and feed dog go forward to get material for the next stitch.

The class 111 machine is a compound feed machine. This means that the feed dog, vibrating presser foot, and needle move together to feed the material. Some class 111 machines are equipped with a compound feed only, such as the 111 W 151; and others are equipped with a combination of the compound feed and alternating presser foot that holds the material while the needle and vibrating presser foot are moving into position for the next stitch, such as the 111 W 155.

Perhaps the description of the feed mechanism gave you a hint that the class 111 sewing machine is a more complicated machine than the class 31. It is indeed.

Timing the 111 W Class Sewing Machines

The first step in timing the 111 W machine is to set the feed driving eccentric on zero stitches per inch (0 spi). Set the needle bar. With the needle bar in its lowest position (needle bar crank in the horizontal position, the rounded portion on the top and driving stud at the bottom), the connecting link will be vertical. Set the needle bar with the upper timing mark just visible at the base of the needle bar rock frame, and tighten the needle bar pinch screw. The needle bar is then properly set.

To set a needle bar that has no mark, set the feed eccentric for eight stitches to the inch. Then set the needle bar so that when it rises $\frac{3}{32}$ inch from its lowest position and the point of the sewing hook is at the center of the needle, the needle eye will be about $\frac{1}{16}$ inch below the hook point.

The next step is to time the arm shaft with the hook drive shaft. With the connection belt removed, rotate the balance wheel toward the operator until the thread take-up lever is at its highest point, then align the arrow on the hook drive shaft collar with the timing plate arrow, and replace the connection belt. Rotate the balance wheel and check. The next step is to center the feeding action. For this step the feed driving eccentric must be set on zero spi. With the needle entering the feed dog, center the needle in the hole

in the feed dog with a distance of $17/32$ inch between the needle bar and the presser bar.

In centering the feeding action, the following sequence should be followed: Hold the needle centered in the feed dog with a $17/32$ -inch space between the needle bar and presser bar. Tighten the feed driving crank and feed driving rockshaft crank pinch screws, making sure that the crank is flush with the end of the feed driving rockshaft and parallel with the bed. Next, tighten the needle bar rock frame rockshaft crank pinch screw in the back of the uprise. **The shank of the presser foot is $17/32$ inch wide and may be used for measuring the space.**

The next step is to set the sewing hook to or from the needle. This is done by moving the hook saddle left or right as necessary; the hook should pass the needle as closely as possible without touching. When this is done, retighten the hook saddle screws. Next, set the sewing hook with the needle. With the needle bar on the upstroke, the lower timing mark on the needle bar should be just visible at the base of the needle bar rock frame. Set the point of the sewing hook in the center of the needle $1/16$ inch above the eye. To advance the sewing hook, move the hook drive gear to the right; and to retard, move the hook drive gear to the left.

NOTE: The first screw in the hook pinion gear and the second screw in the hook drive gear are splined screws. The hook drive gear must be centered in relation to the sewing hook shaft at the bottom of the hook saddle. "

Lubrication of The Class 111 Sewing Machines

Figures 9-24A, 9-25B, and 9-26 show the various lubrication points on class 111 sewing machines. Oiling points are indicated by the unnumbered arrows. Familiarization with the nomenclature of the machines may also be accomplished by studying these illustrations.

To lubricate the class 111 machine, swing back the top cover and oil the bearings, then replace the cover.

Loosen the thumbscrew in the upper end of the faceplate, turn the faceplate upward, and oil the wick and bearings, as shown in figure 9-25B. After oiling, turn down the faceplate and tighten the thumbscrew.

Turn the machine back on its hinges and apply oil at the places designated by the arrows in figure 9-27. All contacting parts on the bottomside of the machine should also be oiled.

To lubricate the hook, remove the bed slide and place oil in the oil well (fig. 9-26). This

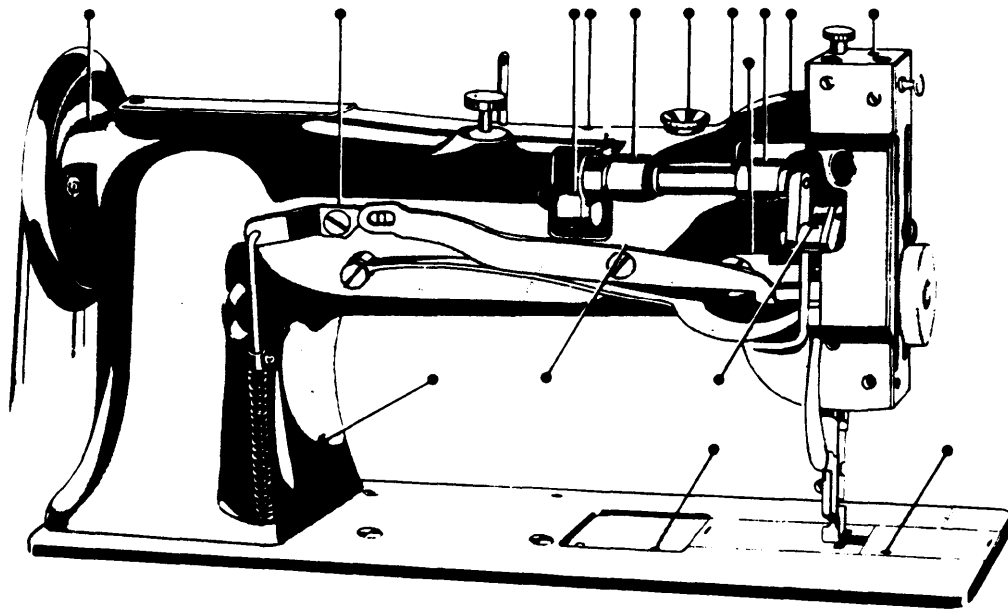
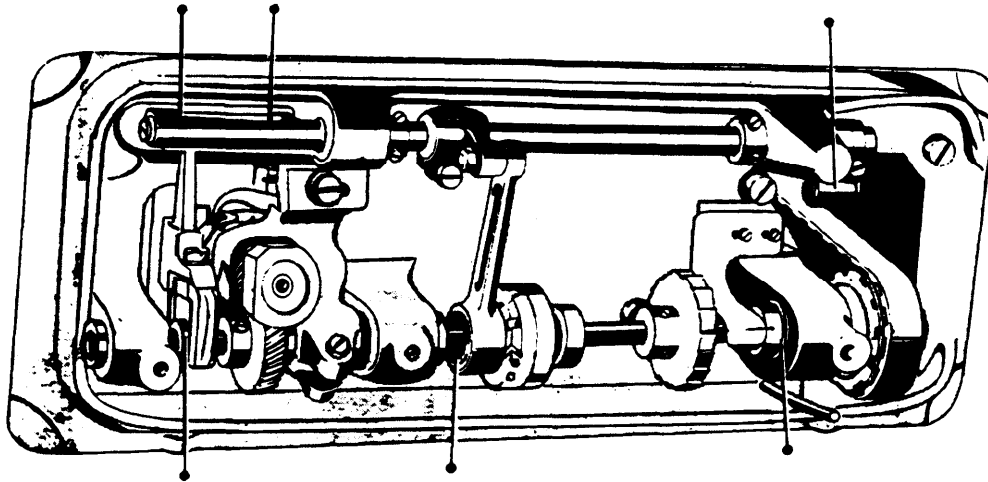

Figure 9-26.—Rear of machine, showing oiling points.

239.283



239.284

Figure 9-27.—Base of machine, showing oiling points.

lubricates the upper hook bearing and the mechanical opener mechanism.

The small, green felt pad on the side of the bobbin case should be kept wet with oil to lubricate the hook race. When this pad is wet, it appears nearly black; when it appears light green, it indicates that it is dry. When a machine is new, oil should be applied to this felt pad EACH TIME A BOBBIN IS REPLACED.

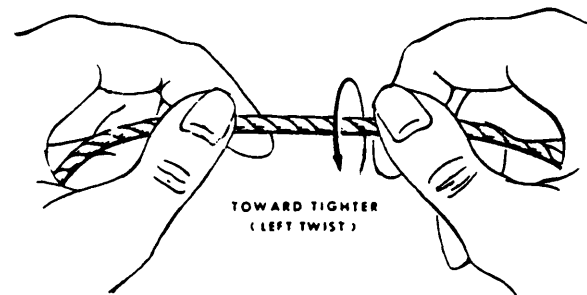

239.267

Figure 9-28.—How to determine the twist of thread.

Needles and Thread

The thread used on rotary sewing machines is left twist. To determine the twist of thread, refer to figure 9-28.

Table 9-3 lists the class and variety of needles and the needle size range for each of the class 111 machines.

The size of needle to be used is determined by the size of the thread and material used. The thread must pass freely through the eye of the needle. If rough or uneven thread is used, or if it passes with difficulty through the eye of the

Table 9-3.—Data for Class 111 Sewing Machine

Sewing Machine	Stitches per minute	Stitches per inch	Needle class and variety	Needle size range
111 W 150	3,500	5 to 32	135 x 7	7 to 24
111 W 151	3,500	5 to 32	135 x 17	14 to 26
111 W 152	2,900	5 to 32	135 x 17	12 to 24
111 W 153	2,900	5 to 32	135 x 17	12 to 24
111 W 154	2,900	5 to 32	126 x 11	22 to 27
111 W 155	3,500	3 1/2 to 32	135 x 17	12 to 24

needle, the machine will not function properly.

Needles used on rotary sewing machines are ordered the same way as those for oscillating sewing machines.

The needles for rotary sewing machines have seven parts. This is one more part other than the needles for the oscillating machines. The additional part is the SCARF, which is a small indentation just above the short thread groove. The purpose of the scarf is to permit the point of the sewing hook to come close enough to pick up the needle thread without striking the needle.

Operation

Operation of rotary sewing machines is the same as for the oscillating sewing machines.

Setting the Needle

Turn the balance wheel toward you until the needle bar moves up to its highest position. Loosen the setscrew in the needle bar and slip the needle up into the bar as far as it will go. The needle must be inserted with its long thread groove toward the left, the eye of the needle being directly in line with the machine bed. Retighten the setscrew.

Threading the Machine

Pass the thread from the thread stand from back to front (fig. 9-29) through the lower hole (1) in the thread post on top of the machine, then from right to left through the upper hole (2) in the post. Pass the thread down through hole (3), up through hole (4), and down through the hole (5) in the thread guide on the front of the machine. Continue the thread over from right to left between the tension disks (6), and down, from right to left, around the thread controller (7). Then the thread should go up into the fork (8) in the thread controller disk against the pressure of the wire controller. The thread is then passed up through the thread guide (9), and from right to left through the hole in the thread take-up lever (10).

Pass the thread down through the thread guide (11), and between the felt pad and the felt pad retainer finger (12). (If the machine you are threading does not have the felt pad and retainer

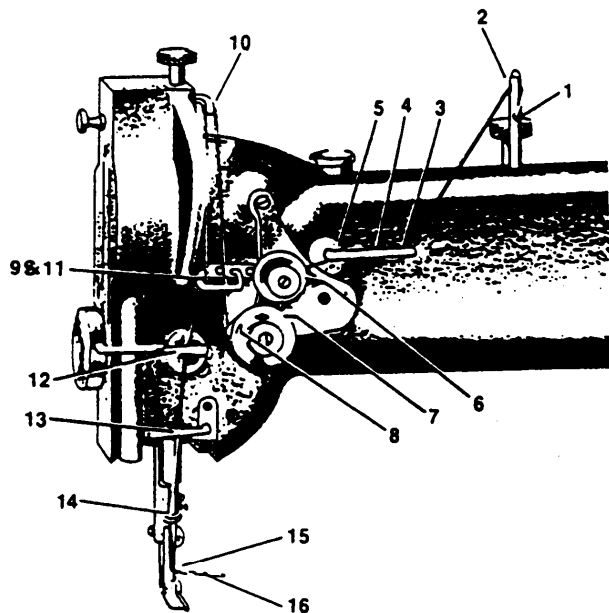

1. Lower hole in thread post
2. Upper hole in thread post
3. Hole in thread guide
4. Hole in thread guide
5. Hole in thread guide
6. Tension disks
7. Thread controller
8. Fork in the thread controller
9. Thread guide
10. Thread takeup lever
11. Thread guide
12. Felt pad and retainer finger
13. Thread guide
14. Thread guide
15. Eye of needle
16. Free end of thread

239.285

Figure 9-29.—Threading the class 111 sewing machine.

finger installed, bypass this component.) Finish the threading by passing the thread down through the thread guide (13), through the thread guide (14) at the bottom of the needle bar, and from left to right through the eye of the needle (15). Always thread a needle toward the bobbin.

Removing the Bobbin

To remove the bobbin, draw out the right-hand slide plate in the bed of the machine. Insert the fingernail of the forefinger under the latch; raise the latch and lift the bobbin out. (See figure 9-30).

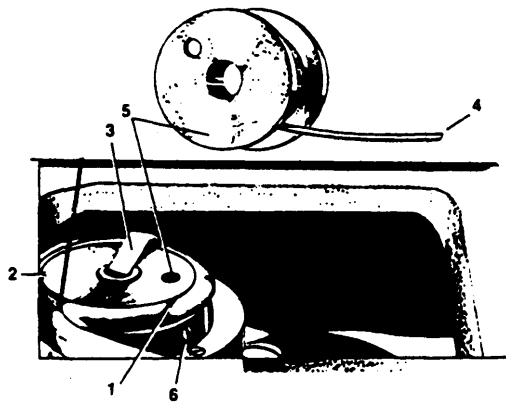

1. Slot in the bobbin case
2. Projection on the bobbin case
3. Bobbin case latch
4. End of bobbin thread
5. Bobbin
6. Tension adjusting setscrew

239.236

Figure 9-30.-Bobbin case threaded.

Winding the Bobbin

To wind the bobbin and adjust the bobbin winder, follow the procedure given for the 31-15 sewing machine.

Replacing the Bobbin and Threading the Bobbin Case

Hold the bobbin between the thumb and forefinger of your right hand with the thread drawn out on the bottom from left to right. Place the bobbin on the center stud of the bobbin case; then push down the latch.

Draw the thread into the slot (1), and under the back of the projection (2). Leave a loose end of thread about 2 inches long above the slide. When closing the slide plate, leave just enough space for the thread to pass through when it is first picked up by the needle.

Regulating the Tension

The tension on the needle thread is regulated by the tension thumb nut located at the front of the tension disks on the front of the machine. To increase the tension, turn this thumb nut clockwise. To decrease the tension, turn the thumb nut counterclockwise.

The tension on the bottom (bobbin) thread is regulated by means of the small screw nearest the

center of the tension spring in the outside of the bobbin case (1), as shown in figure 9-30. To increase the tension, turn this screw clockwise. To decrease the tension, turn the screw counterclockwise.

Regulating the Length of Stitch

The number of stitches per inch is stamped on the stitch indicating disk, which can be seen through the hole on the uprise.

To change the length of stitch, press down the feed regulating stud (plunger), located in the bed of the machine. At the same time, turn the balance wheel slowly until the plunger enters a notch in the adjustable feed eccentric disk. Continue to hold the plunger and turn the balance wheel forward or backward until the number of stitches per inch desired can be seen through the hole in the front of the uprise. Disengage the plunger by releasing it.

Regulating the Pressure on the Material

The pressure on the material is regulated by the presser bar regulating screw at the back of the sewing machine. The screw acts on a flat spring. To increase the pressure, turn this screw downward. To decrease the pressure, turn this screw upward. The pressure should be only heavy enough to enable the feed to move evenly along whatever thickness of material you are using.

Preparing for Sewing

With the left hand, hold the end of the needle (machine) thread, leaving it slack from the hand to the needle. Turn the balance wheel over toward you until the needle moves down and up again to its highest position. If the sewing machine is properly timed, this will bring the bobbin thread up with the machine thread through the hole in the feed dog. Lay the threads back under the presser foot and close the slide.

Place the material under the presser foot. Lower the presser foot either by hand or by the knee lift, and begin to sew. Start the sewing by turning the balance wheel over toward you as you depress the treadle.

Removing the Work

After the machine has stopped, move the thread take-up lever to its highest position. Raise

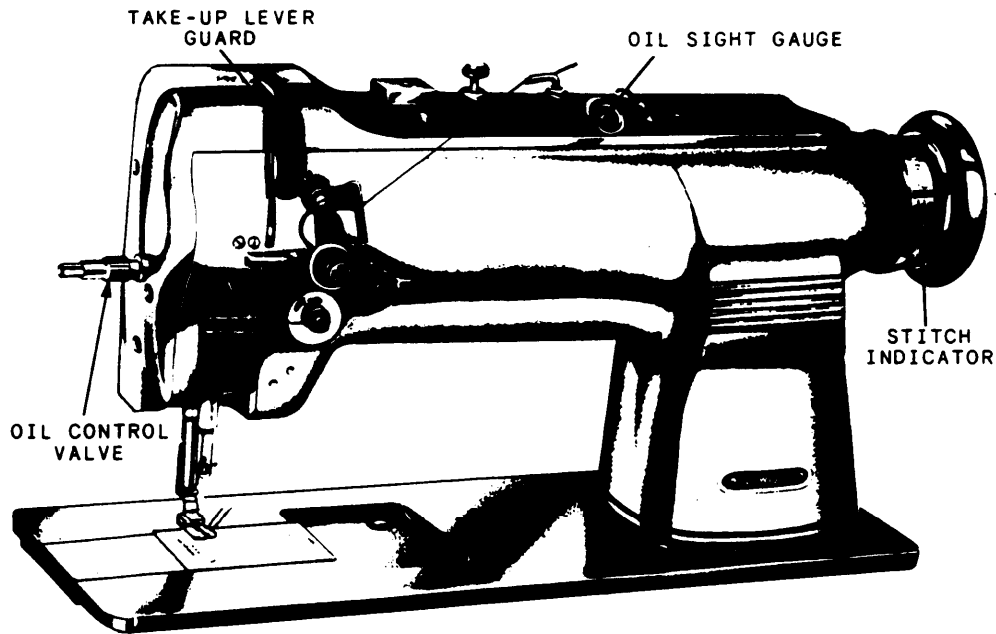

240.80

Figure 9-31.—The 211 W 151 sewing machine.

the presser foot, draw the work back, and cut the threads close to the material. Lay the ends of the threads back under the presser foot.

SINGER SEWING MACHINE 211 W 151

This machine performs the same functions as the 111 W 151. It is a newer model, more streamlined and modern in appearance, and has some design features not found in the 111 W 151 machine. (See figure 9-3 1.) These features include a new lubrication system, a thread take-up lever guard, a thread lubricator, and a new stitch indicator.

The 211 W 151 sewing machine is a high-speed (4,000 rpm maximum), single-needle, lockstitch-type machine, designated for sewing medium to heavyweight fabrics. It is belt-driven and has a rotary hook on a vertical axis, which makes two revolutions for each stitch.

It has a safety clutch (fig. 9-32) that is adjustable to suit the sewing conditions; this protects the sewing hook from damage. If the hook is obstructed by foreign matter, the clutch will disengage and re-engage only after the area has been cleared. The feeding mechanism is a compound drop and needle feed with the longest stitch at five stitches per inch.

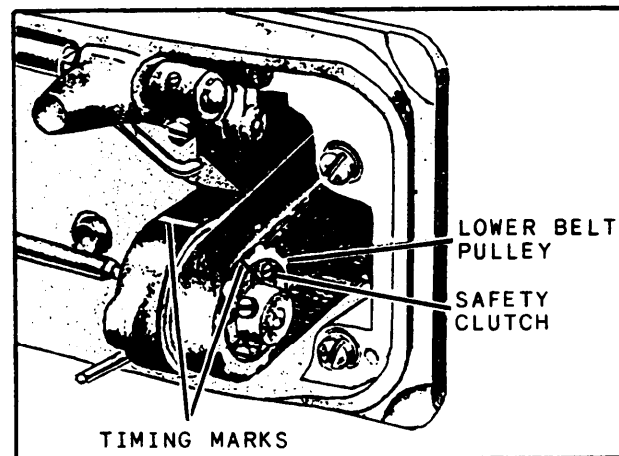

240.81

Figure 9-32.—Safety clutch and lower belt pulley.

Other features of the machine include a hinged presser foot, a presser bar lift of 1/4 inch, a needle bar stroke of 1 5/16 inches, a bed that is 20 3/8 inches long by 7 inches wide, and a space of 10 1/2 inches to the right of the needle.

Needles

The needles used in this machine vary according to the clearance under the presser foot.

Use 135 x 7 needles with machines set with 1/4-inch clearance under the presser foot, and 135 x 17 needles with those set with 3/8-inch clearance (lift).

Adjustments

Adjustments to the 211 W 151 are basically the same as for 111 W 151. These adjustments are discussed in the following text.

SETTING THE NEEDLE BAR.— Place the needle bar up into the needle bar holder as far as possible. Hold in this position and turn the balance wheel toward the operator until the needle bar is at its lowest position. When in this position, set the bar so the upper timing mark is just visible below the needle bar frame, and tighten the needle bar connecting stud pinch screw.

In case the needle bar does not have timing marks, set the machine to zero stitches per inch and place the needle bar up in the holder as far as possible. Turn the balance wheel by hand until the bar is at its lowest position. After reaching the lowest position of the needle bar, continue turning the balance wheel toward the operator until it reaches 3/32 inch above its lowest point, then set the eye of the needle 1/16 inch below the point of the sewing hook.

SETTING THE NEEDLE.— To set the needle, insert the needle shank as far as possible into the needle bar with the long groove of the needle to the left and tighten the screw. (See figure 9-33.)

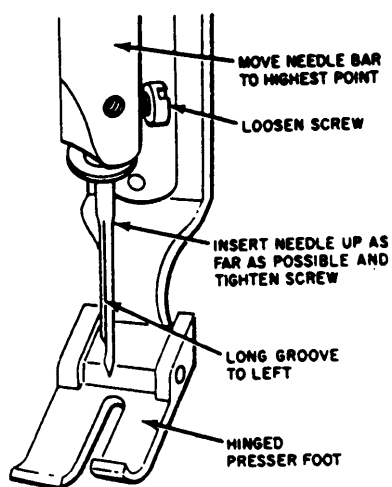
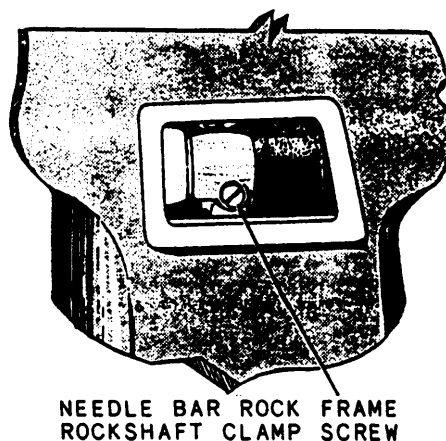

Figure 9-33.—Setting the needle.

240.82



240.83

Figure 9-34.—Needle bar rock frame rockshaft damp screw.

RELATIVE POSITION OF NEEDLE BAR AND PRESSER BAR.— To set the relative position of the needle bar to the presser bar, loosen the needle bar rock frame rockshaft clamp screw, which is located behind the cover plate on the front upright position of the arm (fig. 9-34). Set the needle bar so the distance between the needle bar and presser bar is 17/32 inch. Retighten the clamp screw.

NOTE: A handy tool for this adjustment can be manufactured locally from a thin piece of metal stock filed to exactly 17/32-inch width. This gauge should be placed between the two bars while the clamp screw is being tightened. This enables the operator to keep pressure on the loose needle bar.

ADJUSTMENT HEIGHT OF SEWING HOOK.— Before attempting to adjust the height of the sewing hook, it is necessary to make a feeler gauge for testing the height. This gauge can be made of 0.032-inch shim stock, or a regular feeler gauge can be cut or trimmed down so it will fit in the small groove in the throat plate, which retains the bobbin case stop finger.

If, after testing, the hook height is unsatisfactory, turn the balance wheel so the two setscrews in the bottom of the hook are accessible; loosen them with an Allen wrench. Remove the cloth washer from the bobbin case and turn the hook until the height adjusting screw is directly

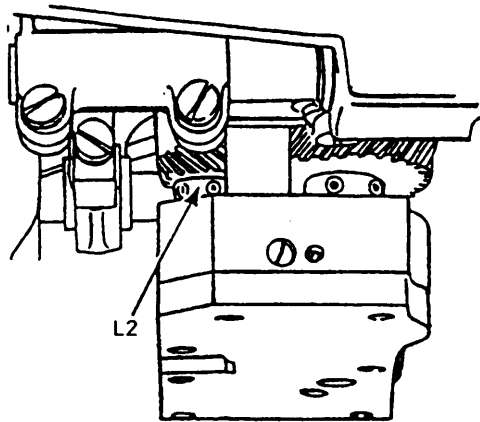

239.450

Figure 9-35.—Timing the sewing hook.

under the hole in the bobbin case. (See figure 9-35.) Turn the screw into raise the hook, and out (while pressing down on the hook) to lower it. The gauge should barely pass between the throat plate and bobbin case stop finger. Retighten the Allen setscrews and turn the adjusting screw in so that a slight tension is left on the screw.

SETTING SEWING HOOK TO OR FROM NEEDLE.— To set the relative position of the

hook saddle to the needle, loosen the hook saddle adjusting screws (fig. 9-36) and slide the hook saddle to the right or left, as necessary, to set the point of the hook as close to the needle as possible (without actually touching). After setting the hook saddle, check the clearance between the hook drive gear and the face of the hook saddle. This clearance should be 0.008 inch; if it is not, reset it by loosening the screw and setscrew in the hook drive gear, and move the gear to the right or left to get the proper clearance.

TIMING BOBBIN CASE OPENER.— To set the bobbin case opener, turn the balance wheel toward the operator until the lower timing mark on the needle bar is barely visible below the needle bar frame on its upward stroke. Tip the machine back and loosen the two Allen screws in the bobbin case opener drive gear; then line up the timing marks by turning the opener shaft with a screwdriver. The timing marks are located as follows: one on the flange of the opener, and the other on the hook saddle (fig. 9-35). Adjust the opener so it lightly touches the bobbin case and turns it enough to make a sufficient opening for a free passage of thread between the bobbin case stop finger and the throat plate. Tighten the screws in the bobbin case opener drive gear.

RAISING OR LOWERING THE FEED DOG.— To raise or lower the feed dog, remove

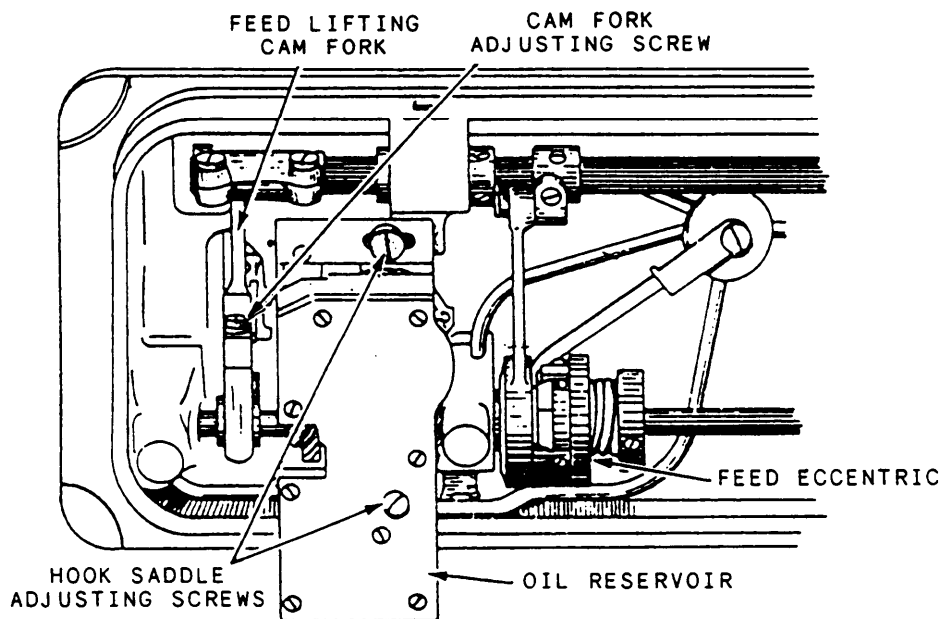

240.85

Figure 9-36.—Hook saddle assembly showing bobbin case raceway oil reservoir.

the throat plate and clean all lint and dirt from between the grooves and teeth of the feed dog. Tip the machine back and turn the balance wheel toward the operator until the feed dog is in its highest position. Loosen the screw in the feed lifting cam fork and raise or lower the dog as desired; then retighten the screw. A properly set feed dog will show a full tooth above the throat plate when at its highest position.

After adjusting the feed dog, check to see that the needle is properly set in the hole in the feed dog. If adjustment is needed, loosen the pinch screws in the feed driving rock frame, and set the needle so that when it is all the way down, it will be slightly forward of center in the hole. Retighten the pinch screws. The feed adjustment points are illustrated in figure 9-37.

ADJUSTING FEED ECCENTRIC.— The feed eccentric (fig. 9-38) may occasionally need adjustment to remove play caused by wear of the gib, or by looseness between the feed eccentric and the eccentric body. To adjust the gib, loosen the two locking screws, then turn inward on the adjusting screws until all play is eliminated and the eccentric fits in the slot properly.

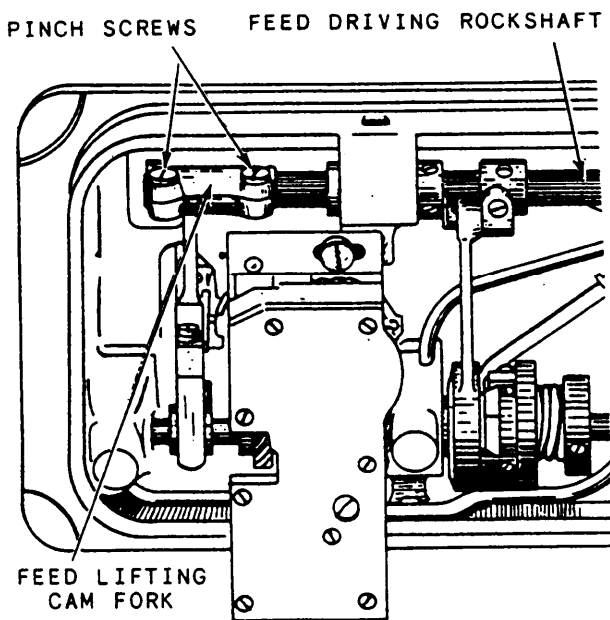

240.86

Figure 9-37.—Feed adjustment for the 211 W 151 sewing machine.

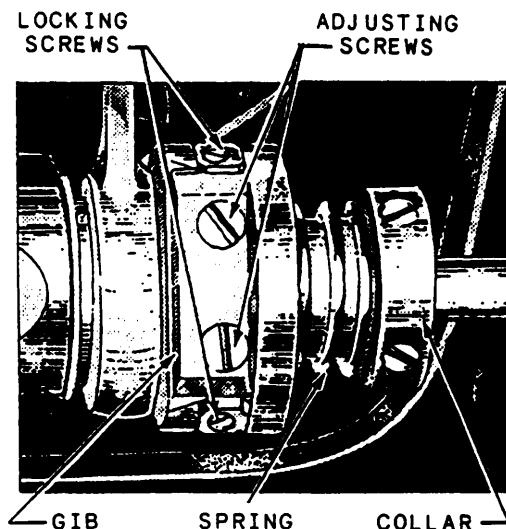

240.87

Figure 9-38.—The feed eccentric.

CAUTION

LOCKING SCREWS MUST BE LOOSENED BEFORE ATTEMPTING TO LOOSEN ADJUSTING SCREWS. RETIGHTEN THE LOCKING SCREWS AFTER ADJUSTMENT IS MADE.

The feed eccentric collar may be moved to the right or left to change spring tension, but it is ordinarily set flush with the hub of the eccentric body.

CHANGING THE LENGTH OF THE STITCH.— TO change the length of stitch, stop the machine. Turn the balance wheel, by hand, toward the operator until the button drops (clicks), then turn the machine pulley until the number representing the desired stitches per inch is lined up properly and then release the button.

CAUTION

DISENGAGE THE BUTTON BEFORE ATTEMPTING TO SEW. DO NOT ENGAGE THE BUTTON WHILE THE MACHINE IS IN OPERATION.

Removing Components

To remove the hook, takeoff the presser foot, throat plate, and feed dog; then loosen the two

Allen screws in the hub of the hook and lift the hook off the hook shaft. To remove the bobbin case from the hook assembly, loosen the hook gib screws, lift off the gib, and then lift out the bobbin case.

Removing the Arm Shaft Connection Belt

When the arm shaft connection belt is disconnected for any reason, the machine will be completely out of time. Therefore, the needle should be removed before removing the belt to prevent damage. To remove the belt, slide it off the lower belt pulley, loosen the screws in the machine pulley, and remove the pulley and ball bearing, which come out through the end of the arm.

Replace the belt by reversing this procedure. Remove the end play from the shaft by lightly setting the setscrews and tapping the balance wheel into position with the palm of the hand and then securely setting the setscrews. Place the belt over the upper belt pulley and line up the timing marks on the lower belt pulley and on the bed of the machine. While holding the lower belt pulley in position, turn the balance wheel toward the operator's position until the thread take-up lever is at its highest position, then slide the belt onto the lower belt pulley. The arm shaft connection belt and the lower belt pulley are illustrated with the safety clutch in figure 9-32.

CAUTION

DO NOT TAMPER WITH THE SAFETY CLUTCH. ITS TORQUE IS PRESET AT THE FACTORY.

Lubrication

The hook saddle is equipped with an oil reservoir (fig. 9-36), which contains oil to be pumped to the bobbin case raceway. The flow of this oil is controlled by a control valve screw located just aft of the bobbin case opener in the hook saddle. For more oil, turn the valve screw clockwise; counterclockwise for less oil.

CAUTION

DO NOT ADJUST FLOW OF OIL WITHOUT FIRST LOOSENING THE

LOCKING SCREW LOCATED ON THE SIDE OF THE HOOK SADDLE JUST ABOVE THE CAM SHAFT GEAR. AFTER ADJUSTING THE CONTROL VALVE SCREW FOR PROPER FLOW, RETIGHTEN THE LOCKING SCREW.

SINGER SEWING MACHINE 143 W 2 AND 3

This type of machine is not as common as those previously described, but it has unlimited uses in the repair and maintenance of parachutes and survival equipment.

The 143 W 2 is a high-speed sewing machine that has an aluminum alloy vibrating needle bar frame and a rotary hook. It is intended for overseaming and zigzag stitching on fine and general fabrics and lightweight leather. It has ball bearings on the rear end of the arm shaft and hook driving shaft. The needle bar has a maximum throw of 3/16 inch, vibrating both sides of a centerline.

The 143 W 3 sewing machine is similar to the 143 W 2 except that the needle has a maximum throw of 5/16 inch.

The maximum speed recommended for machine 143 W 2 is 3,500 stitches per minute, and for machine 143 W 3, 3,000 stitches per minute, the speeds depending on the material being sewn.

Needle and Thread

The needles for the 143 W 2 and 143 W 3 sewing machines are of class and variety 135 x 7; the sizes from 7 to 24.

Left twist thread should be used on these machines. To make a smooth even stitch with the sewing machine, use good, firmly twisted and smoothly finished thread. The thread should pass freely through the eye of the needle.

Setting the Needle

Push the needle up in the needle bar as far as it will go, with the LONG THREAD GROOVE TO THE FRONT, and secure it firmly with the setscrew. It may be necessary to turn the needle slightly to the right or left for some threads if stitches are missed.

Bobbin and Bobbin Case

The procedure for removing the bobbin case, winding the bobbin, threading the bobbin case, and replacing the bobbin case is the same as for the 31-15 sewing machine. The only exception to this is that when the bobbin case is threaded, the thread should be drawn from the **BOTTOM** from left to right, instead of from the top as given for the 31-15.

Threading the Needle

These machines are threaded in the same way as the 111 series machines, described earlier in the chapter. When threaded up to the needle, thread the needle from the front through the eye to the back. The long thread groove should be in front when the needle is properly set in the needle bar.

Regulating the Length of Stitch

To adjust the length of stitch, depress the stitch regulator lever (fig. 9-39) on the uprise and, at the same time, turn the balance wheel forward until the lever engages in the notch in the stitch

regulator flange. Hold the lever in the notch and turn the balance wheel backward or forward (as necessary) until the desired number of stitches per inch is shown opposite the arrow on the stitch regulator.

Regulating the Width of the Zigzag

The extreme width of the zigzag (needle throw) on the 143 W 2 is $\frac{3}{16}$ inch; it is $\frac{5}{16}$ inch on the 143 W 3. The width of bight is regulated by turning the knurled knob on the needle vibrator regulating spindle head (fig. 9-39) at the front of the machine. To increase the width of the stitch, turn the regulating spindle head to the left, and to the right to decrease.

Setting the Needle Bar

The two adjustment marks on the needle bar are $\frac{3}{32}$ inch apart. To set, insert the needle bar up into the needle bar frame so the upper mark is just visible at the lower end of the needle bar frame with the bar at its lowest position. The eye of the needle should be $\frac{1}{16}$ inch below the point

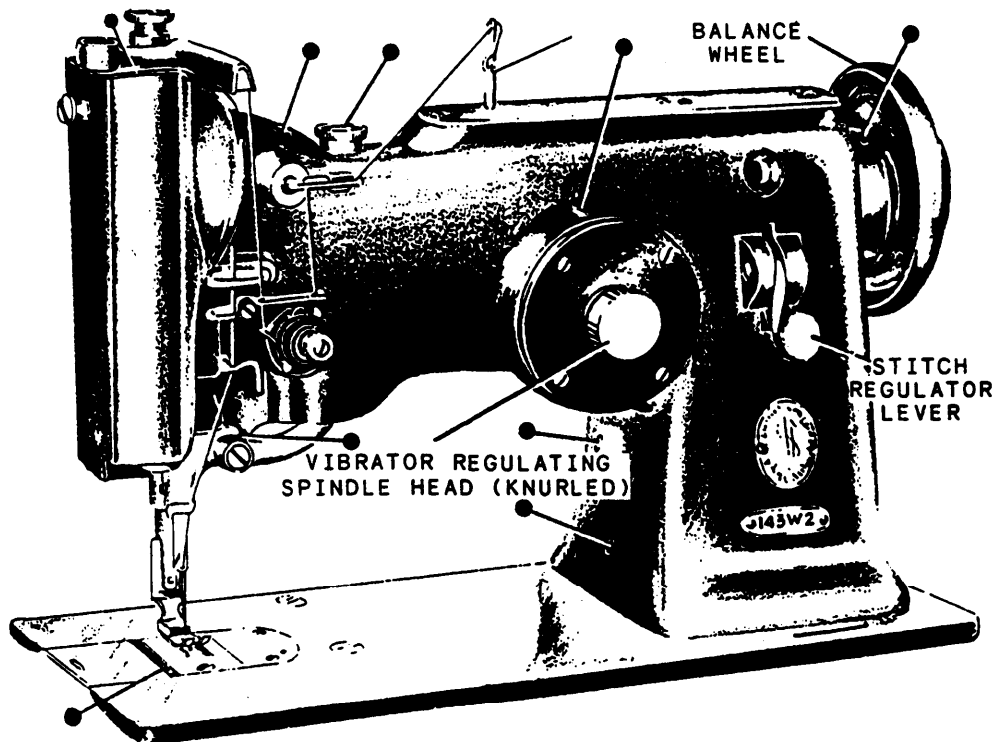

Figure 9-39.—Oiling points at the front of the 143 W 2.

239.293

of the hook, and the long thread groove toward the operator.

Setting and Timing the Needle Bar Frame

Turn the regulating spindle head all the way to the right. This will cause the machine to sew a straight stitch. The needle should be centered in the hole in the throat plate. If not, loosen the setscrew that holds the eccentric stud (1) and turn the stud until it is centered (fig. 9-40.) Turn the needle regulating spindle head (5) to the extreme left for the widest throw. Turn the balance wheel forward until the needle is at its lowest position. The needle bar should start to move in a sideward movement as the needle starts to rise. If it does not, you must advance or retard the vibrator pinion gear (2), shown in figure 9-40.

Timing Sewing Hook

Turn the balance wheel toward the operator's side until the needle bar is all the way down and has risen until the lower timing mark is just visible below the needle bar frame. Loosen the setscrews (10) in the lower belt pulley (fig. 9-41) and set the hook point to the center of the needle eye. Retighten the setscrews.

Setting the Hook Distance To or From Needle

Loosen the two hook shaft retaining screws (8) (fig. 9-41) and the two screws in the hook pinion gear (7), and slide the hook to the correct position. Retighten the hook shaft retaining screws. Set the gear in the proper place on the shaft—gear aligned with hook drive gear—and

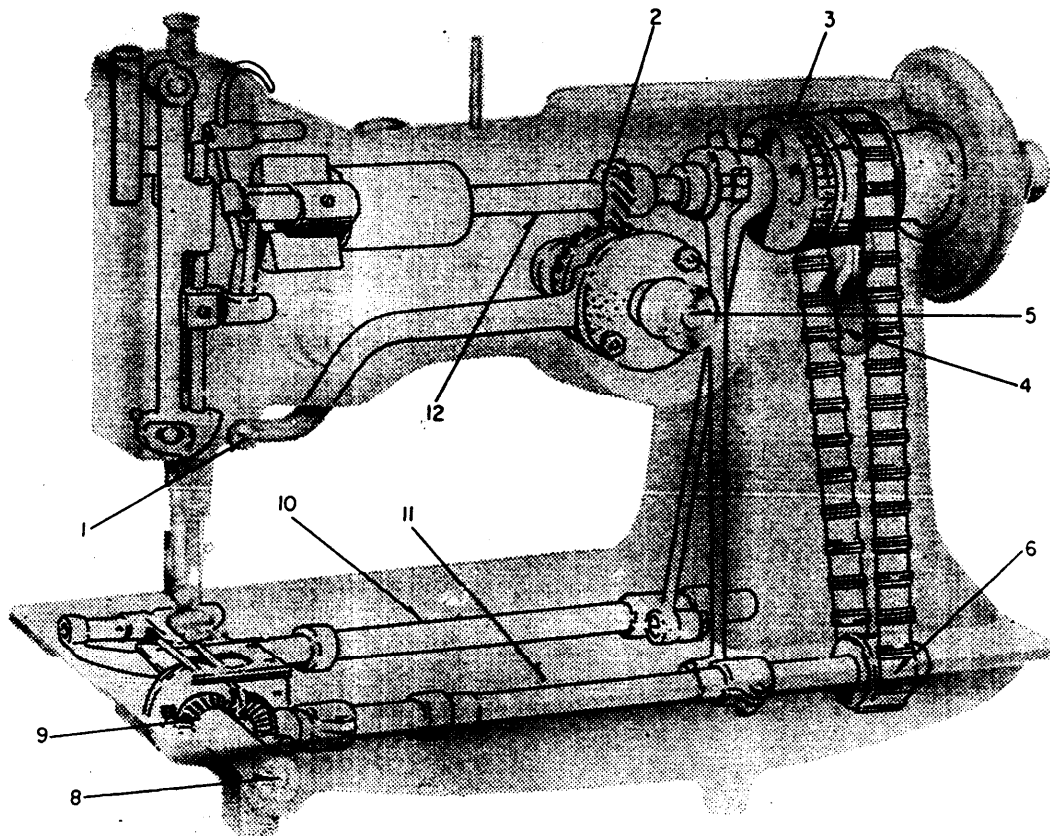

- 1. Eccentric stud
- 2. Vibrator pinion gear
- 3. Stitch regulator
- 4. Stitch regulator lever

- 5. Regulating spindle head
- 6. Lower belt pulley
- 7. Hook drive gear
- 8. Hook spindle screw

- 9. Hook pinion gear
- 10. Feed driving rockshaft
- 11. Hook drive shaft
- 12. Arm shaft

Figure 9-40.-X-ray view of zigzag sewing machine.

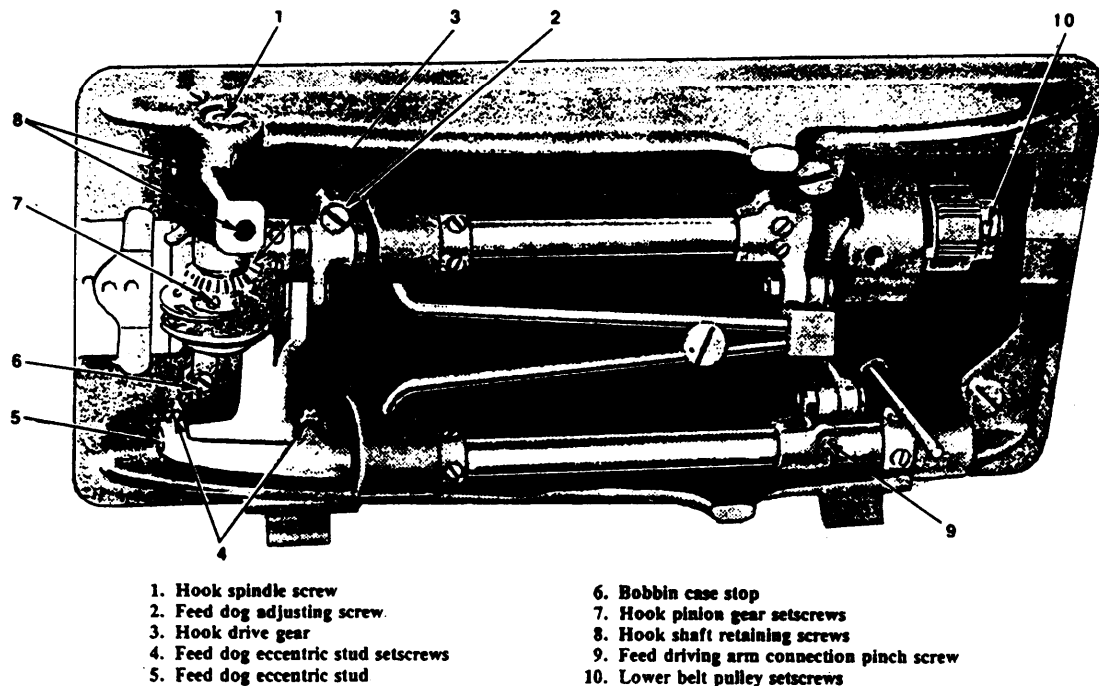

Figure 9-41.—Adjustments in the bed of the machine.

240.93

retighten the two setscrews to hold the hook in position.

Raising or Lowering the Feed Dog

The feed dog should show a full tooth above the throat plate when at its highest position. To adjust the dog, remove the throat plate and make sure all lint, dirt, or other obstruction is removed, then replace the throat plate. Turn the balance wheel forward until the feed dog is at its highest position; then loosen the feed dog adjusting screw (2) (fig. 9-41), and raise or lower the feed dog as required. Retighten the adjusting screw to hold the feed dog in position.

To prevent the feed dog from striking either end of the slots in the throat plate, loosen the pinch screw (9) (fig. 9-41) and move the feed dogs forward or backward (as necessary) until the longest stitch can be taken without striking the throat plate.

Sewing Techniques

In this chapter we pointed out the need to let the machine feed the material being sewn, and

other techniques to obtain a good seam. At first you will find it very difficult to turn corners when using a sewing machine. If you will follow these instructions you will find it very easy to make a turn and not lose your stitch.

Stop the machine while the needle is rising, but before it is out of the material, raise the presser foot and turn the work. This method uses the needle as a pivot. When the material lies in the new position, lower the foot and continue sewing.

Removing the Work

Raise the presser lifter and turn the machine by the balance wheel until the take-up lever is at its highest position. Draw the work out away from you. If the threads do not draw out easily, the take-up lever is not in the right position. If the machine is stopped as directed, the needle will not be unthreaded when you start to sew, even if only a short end is left through the eye of the needle.

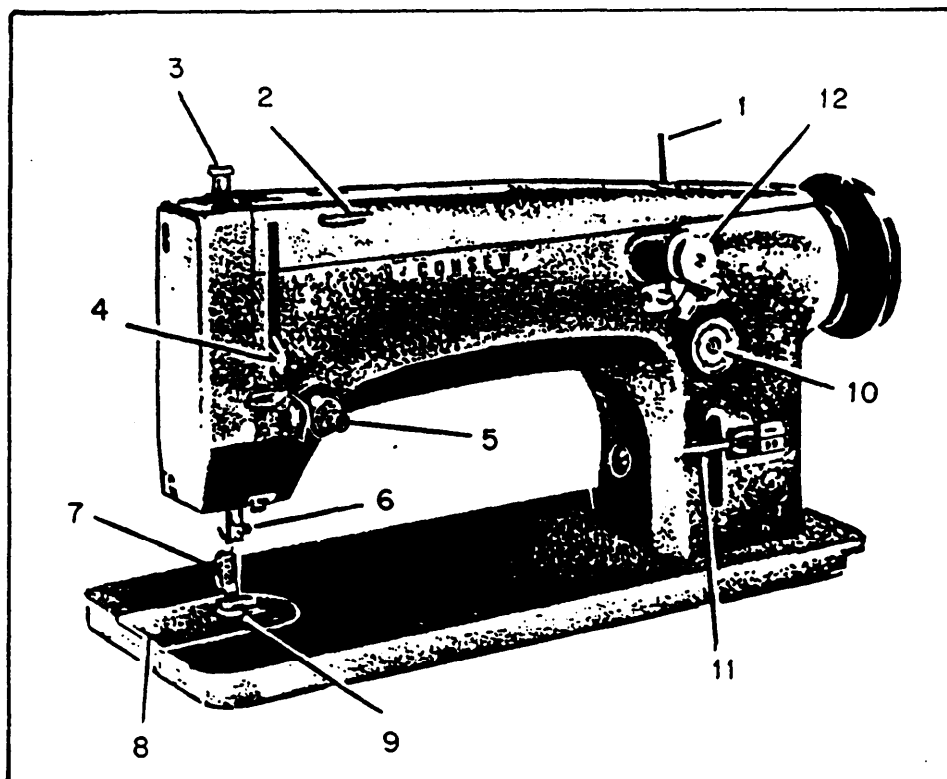

- | | |
|-----------------------|--|
| 1. Spool pin | 7. Presser foot |
| 2. Thread guide | 8. Slide plate |
| 3. Pressure regulator | 9. Needle Plate |
| 4. Take-up lever | 10. Stitch length regulator |
| 5. Tension regulator | 11. Feed direction lever (for tacking) |
| 6. Needle bar | 12. Zigzag width regulator |

Figure 9-42.-Consew 99R.

239.451

CONSEW 99R and 99R-3 SEWING MACHINE

The Navy has recently acquired new model zigzag sewing machines (fig. 9-42), model 99R-3 is not shown, capable of the rope sewing needed to install the four-line release system. Two models are available-the 99R and the 99R-3. Both models are rotary hook-type machines. They are fairly conventional machines, and the operation of both is very similar to that of the machines we have already discussed.

Models 99R and 99R-3 machines are identical in outward appearance; the difference is in the type of stitch they make. In model 99R, every successive stitch forms a symmetrical zigzag pattern stitch, type 304. In

model 99R-3, a zigzag pattern is formed by successive pairs of stitches, type 308.

Threading the 99R and 99R-3 Machines

Follow the instructions below when threading the needle and bobbin on the 99R and 99R-3 sewing machines:

1. Turn the balance wheel toward you until you are able to position the needle so you can place the thread through its eye. Remember, always thread the needle toward the bobbin. In this case, you run the thread from front to back.

2. Hold the loose end of the needle thread in your left hand, turn the hand wheel toward

you with your right hand until the needle moves down and up again to its highest position.

3. Pull the needle thread gently and the bobbin thread will come up with it through the hole in the needle plate.

4. Place both ends of the thread beneath and in back of the presser foot.

5. With the needle at its highest point, place the material to be sewn beneath the presser foot and fully lower the presser foot lifter lever.

6. Start sewing.

Regulating the Tension

Tension is the key word to good sewing. For perfect stitching, the tension of the upper and lower threads should be balanced and just sufficiently tight to lock both threads in the center of the material (look again at figure 9-16).

The machine is correctly adjusted to make a perfect stitch before leaving the factory. When adjustments do become necessary, the problem is more likely to be caused by the upper thread tension, so always begin there. To adjust the upper thread tension, proceed as follows:

1. Lower the presser foot. Remember upper thread tension adjustments must be made with the presser foot down.

2. Check the upper thread tension. If it is loose, turn the tension nut (A in fig. 9-43)

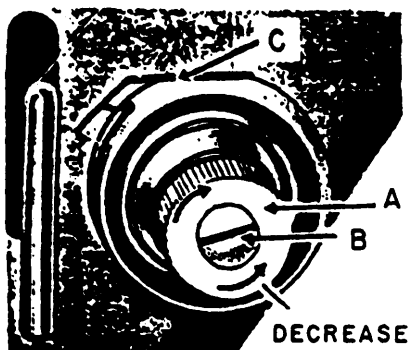

239.452

Figure 9-43.—Upper thread tension.

clockwise to increase the tension; if the upper thread tension is tight, turn the tension nut counterclockwise to loosen it.

Adjusting the Bobbin Thread Tension

When you find it necessary to adjust the bobbin thread tension, turn the tension screw (T of fig. 9-44) on the bobbin case clockwise to increase the tension, and turn the screw counterclockwise to decrease the tension.

Regulating the Pressure of the Presser Foot

The pressure of the presser foot should be adjusted according to the type of material being sewn. The heavier the material, the heavier the pressure. The lighter the material, the lighter the pressure. The pressure should be only heavy enough to prevent the material from rising with the needle and to enable the feeder mechanism to move the work along evenly. The pressure becomes tighter as the regulating thumbscrew is turned clockwise, and looser as the thumbscrew is turned counterclockwise (fig. 9-45).

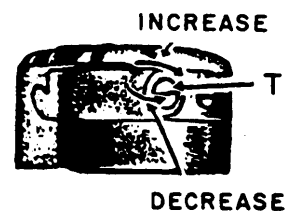

239.453

Figure 9-44.—Bobbin thread tension.

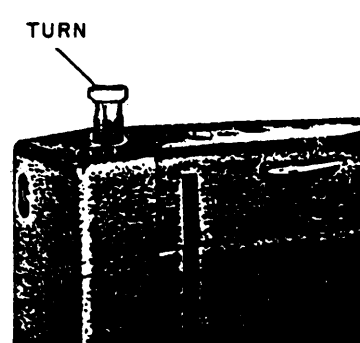

239.454

Figure 9-45.—Adjusting the presser foot pressure.

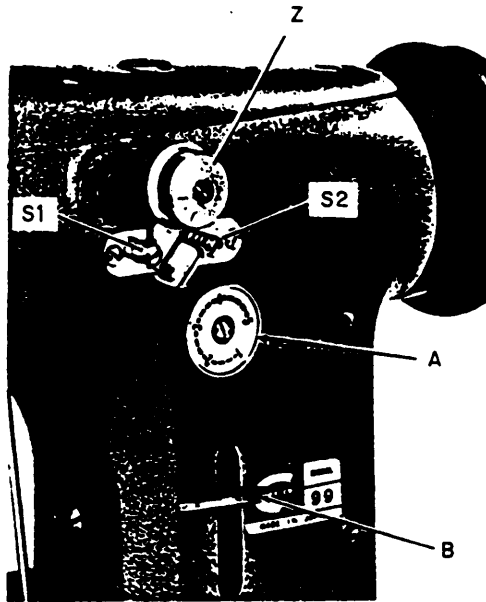

239.455

Figure 9-46.—Stitch regulator.

Stitch Regulator and Reverse Sewing and Tacking

For reverse sewing and tacking, proceed as follows:

1. When the number 1 on dial A of figure 9-46 is set uppermost on a vertical line, the feeder does not move the material.
2. When the dial (A) is turned counterclockwise and lever (B) is raised as far as it will go, the machine makes forward stitches, increasing in size as the dial knob is turned toward the larger numbers.
3. For reverse sewing, lower the lever (B) as far as it will go.
4. By moving the lever up and down during sewing, you can easily make forward or reverse stitches continuously and at will. You can make use of this feature for locking the thread at the start or end of seams.

Straight and Zigzag Sewing

Be sure that stops S1 and S2 are set at the extreme ends of their slot. If not, use a screwdriver to loosen them about one turn, and then tighten them in their extreme positions. Turning the zigzag regulating knob Z clockwise as far as it will go causes the machine to sew with a straight stitch. Turning this knob counterclockwise produces a

zigzag stitch. The zigzag becomes wider the more this knob is turned in a counterclockwise direction. The widest zigzag stitch is sewn when knob Z cannot be turned any further. This occurs when the pointer at the underside of knob Z points at the largest number on the dial and is stopped by stop S2.

When you want to control the width of the zigzag between certain minimum and maximum limits between the numbers on the dial, use a screwdriver to set stops S1 and S2 to the selected widths. Be sure to set stop S1 as far to the left as possible when a straight stitch is desired.

NOTE: The zigzag regulating knob can be moved into any desired position while the machine is operating. Do not turn the zigzag regulating knob when the machine is at rest and the needle is in the material. If you do you may bend or break the needle. Turn the handwheel toward you to raise the needle out of the material before operating the regulating knob.

Preparing the Machine for Rope Stitching (Model 99R-3 only)

For rope stitching, the standard combination of presser foot, feed dog, and (throat) needle plate is replaced with a special set of components designed specifically for this purpose. To do this, move slide plate (S of fig. 9-47) as far to the left

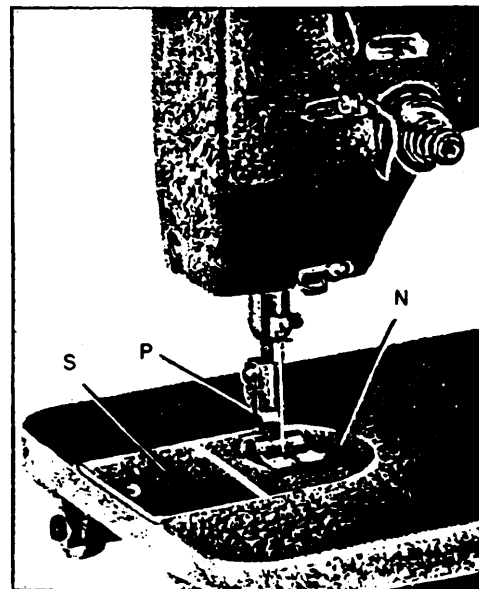

239.456

Figure 9-47.—Rope stitching.

as it will go. Using a screwdriver, remove the two screws holding the needle plate (N) to the bed of the machine. Remove presser foot (P) from the presser bar and lift the needle plate off the bed. Now the feed dog becomes exposed. Loosen the two screws that attach the feed dog to its carrier, and remove the feed dog.

Proceeding in reverse order, first install the special rope-sewing feed dog on the feed dog carrier, making certain that the two screws are tightened well. Next, put in place the special (throat) needle plate, and then the special presser foot, tightening all their screws securely, and close the slide plate.

Adjust the stitch length and the width of zigzag to suit the rope to be sewn.

Setting the Needle Bar at the Correct Height

Before adjusting the height of the needle bar, make sure that the needle is pushed up into the needle bar as far as it will go. Now, remove the faceplate from the machine. Set the zigzag control knob for straight sewing and turn the handwheel toward you until the needle reaches the lowest point of its downward stroke. See that the needle enters the needle slot in the throat (needle) plate at the very center. When the needle is centered, proceed in the following manner:

Remove the slide plate, needle (throat) plate and feed dog. Continue turning the handwheel toward you until the needle bar has risen approximately $\frac{3}{32}$ inch above its lowest position. The point of the sewing hook should now be at the center of the needle at a distance approximately $\frac{3}{32}$ inch above the eye.

If adjustment should be required, loosen the setscrew (B of fig. 9-48) in the needle bar connecting stud to raise or lower the needle bar as may be necessary. Be sure to tighten the setscrew after making this adjustment.

Centering the Needle in the Throat (Needle) Plate

If the needle needs centering within the needle slot in the needle (throat) plate, set

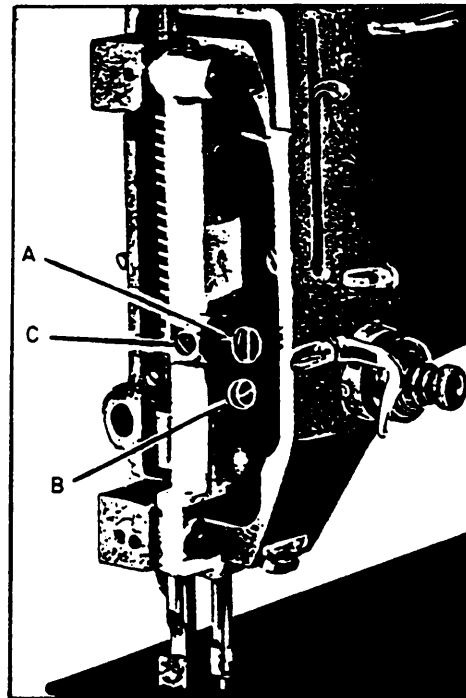

239.457

Figure 9-48.-Setting needle bar.

the machine for straight sewing and turn the handwheel toward you until the needle bar reaches the lowest point of its downward stroke. Loosen setscrew (C of fig. 9-48) and turn eccentric stud (A of fig. 9-48) until the needle is centered correctly. Retighten setscrew (C).

Set the zigzag knob to the widest stitch position and turn the handwheel toward you. Observe the passage of the needle through the needle (throat) plate. It should pass at about an equal distance from either end of the needle slot when making the left and right zigzag stitch. If necessary, readjust the eccentric stud (A of fig. 9-48) as described before.

Timing the Sewing Hook

Remove the presser foot, slide plate, throat (needle) plate and bobbin case. Also remove the feed dog. With a new needle in the machine, turn the handwheel toward you until the needle bar reaches its lowest point. Continue turning and allow the needle bar to rise about $\frac{3}{32}$ inch while on its upward stroke. With needle bar in this

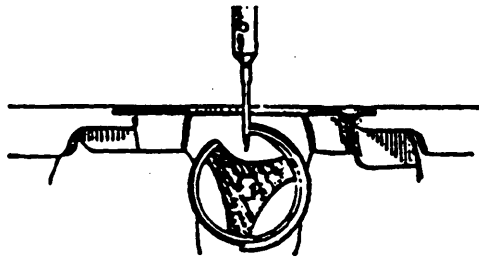

239.458

Figure 9-49.—Timing sewing hook.

position, the point of the sewing hook should be at the center of the needle (fig. 9-49).

If the sewing hook is not timed correctly, loosen the three setscrews in its hub. Turn the hook on its shaft to align the point with the center of the needle, as shown in figure 9-50. Tighten the three setscrews.

To Remove and Replace the Sewing Hook

Remove the needle, slide plate, and bobbin case. Take out screw (D of fig. 9-50) and remove hook retainer (E of fig. 9-50). Loosen the three setscrews in the hub. Turn the handwheel until the thread guard (widest part) of the hook is at

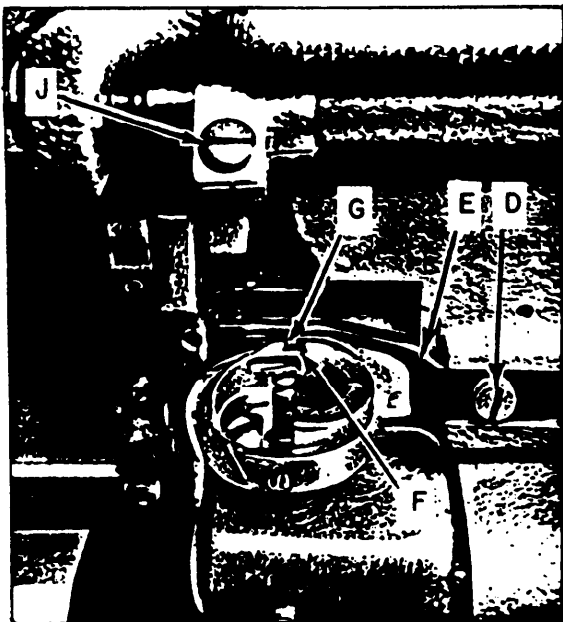

239.459

Figure 9-50.—Sewing hook.

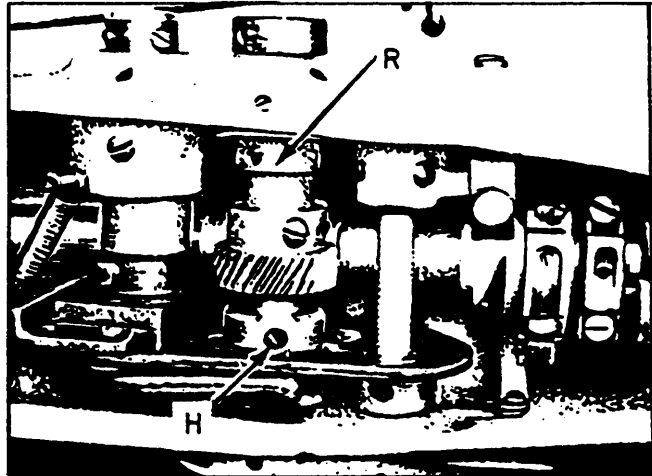

239.460

Figure 9-51.—Removing sewing hook.

the bottom, then remove the sewing hook from its shaft (fig. 9-5 1).

When installing a new sewing hook, have the thread guard at the bottom. Now turn the bobbin case holder until the notch (F) is at the top. Replace the hook retainer (E) watching that the projection (G) near its end (fig. 9-50) enters notch (F) in the bobbin case holder. Fasten the hook retainer to the underside of the bed by means of its screw. Replace the needle and time the sewing hook as described in the preceding paragraph. Reinstall the bobbin case, throat plate, and slide plate.

Timing the Feeding Mechanism

The feeding mechanism is timed at the factory for average stitching performance. Normal timing is such that the feed dog teeth, rising from their lowest position, should be just flush with the surface of the throat (needle) plate after the needle point has traveled about 5/16 inch above the plate while on its upstroke.

To adjust the feeding mechanism, remove the top cover from the machine. Turn the handwheel toward you until the two setscrews, which lock the feed eccentric into the main shaft, come into view (fig. 9-5 1). Loosen both setscrews; lightly tap the feed eccentric toward you to advance the feed timing. To retard the feed timing, tap the eccentric to rotate it toward the rear of the machine.

NOTE: Rotate the eccentric no more than about 1/16 inch, then tighten its setscrews and check for results.

Timing the Movement of the Needle Bar Frame

Set the zigzag knob for straight stitch. Turn the handwheel and observe the travel of the needle into and out of the needle slot in the throat (needle) plate. If the needle is not centered in the slot, make the adjustments that have been described.

Now adjust the needle to produce the widest zigzag stitch. Turn the handwheel toward you and observe vibration (sidewise movement) of the needle bar. The needle bar, on its upward movement, should begin to vibrate when the point of the needle is no less than about 3/32 inch above the throat plate, and should stop vibrating when the needle has reached approximately the same position on its downward movement. To adjust the vibration of the needle bar on model 99R, loosen the setscrews (H of figure 9-51) in the vibrator cam and slightly turn this cam on its shaft. Tighten the setscrews and check for results.

On model 99R-3, the vibration of the needle bar is produced by a plate cam located at R on figure 9-51. Loosen its setscrews and slightly turn the cam on its shaft, following the same procedure as outlined in the preceding paragraph. Be sure to retighten the setscrews.

To Raise or Lower the Feed Dog

When at its highest position, the feed dog should usually rise above the throat (needle) plate the full depth of the teeth.

To adjust the position of the feed dog, loosen screw (J of fig. 9-50) and raise or lower the feed dog; then tighten the screw. When raising or lowering the feed dog, be careful that its underside does not drop so low that it strikes the hook.

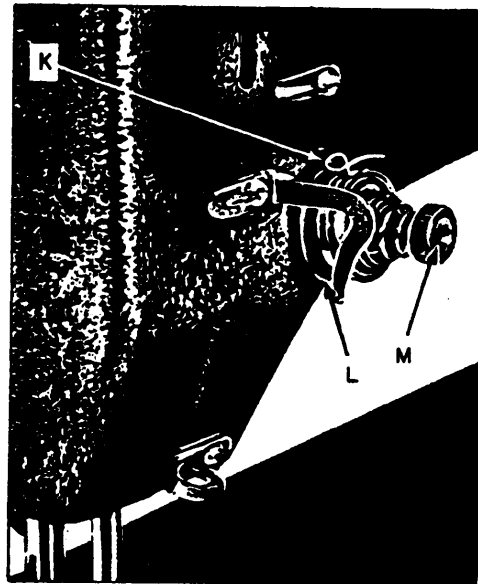

239.461

Figure 9-52.—Adjusting thread take-up spring.

Adjustment of the Thread Take-up Spring

The thread take-up spring (K of fig. 9-52) should be set so that when the eye of the needle reaches the material on the downward stroke, the spring has completed its action and rests against the top of the thread take-up spring regulator.

If the thread take-up spring is not correct, loosen setscrew (L of fig. 9-52) and turn the tension stud (M) to the left for reduced movement of the spring, or to the right for more movement. After the take-up spring is set correctly, tighten setscrew (L).

Regulation of the tension of the thread take-up spring (K) is done by turning the tension stud (M) to the right to increase tension or to the left to decrease it. Tension of the spring should just be enough to take up the slack of the needle thread until the eye of the needle reaches the material on its downward movement.

CHAPTER 10

FABRICATION AND MANUFACTURE

Learning Objective: Upon completion of this chapter, you will be able to identify and understand the tools, equipment, and procedures used to cut, layout, and fabricate specified projects.

As an Aircrew Survival Equipmentman, you need to know what materials are best suited for the job at hand if you are to be considered a master craftsman of your trade. Therefore, to lay the groundwork to aid you in becoming a skilled PR, this chapter discusses the textile materials, tapes, webbing, thread, cards, knots, and seams you will use.

Many of the repairs you will be required to make can be accomplished by replacing missing or worn hardware. There are occasions when minor repairs require hand sewing because machine sewing is impractical or impossible. For instance, it might be advisable to make minor repairs to aircraft upholstery by hand sewing the repair in the aircraft rather than by bringing the item to the shop. On the other hand, most sewing is done by a sewing machine. A seam is usually constructed faster, and is more durable, when a sewing machine is used. The use of a sewing machine gives the seam a better appearance. To do your job right, you must know the types of handmade and machine-made seams and how to make them.

TEXTILE MATERIALS, TERMS, AND MEANINGS

When a PR talks about warp, he doesn't mean something's out of shape; and when he talks about filling, he isn't referring to teeth. He's using terms textile manufacturers use, terms that are standard throughout the textile industry. The Navy uses these standardized textile terms to identify and classify materials on Navy stock lists. Aircrew Survival Equipment Changes and Bulletins also contain some of these terms. To comply with these repair instructions, you must first understand the terms used in them.

FIBER AND FILAMENT

Fiber is the basic unit used in the fabrication of textile yarns and fabrics. Vegetable, animal, and mineral fibers are natural fibers; nylon, dacron, and rayon are synthetic fibers. A filament is an individual strand of material, and can be any length. *Filament* is also another word for fiber, usually used when indicating or referring to synthetic fibers. A fiber, or filament, is the smallest unit in any type of cloth. An example is a silk filament, which may vary in length from 300 to 1,000 yards. Synthetic filaments may be several miles long.

Staple

The staple is the smallest unit of a naturally occurring fiber, or a synthetic filament cut in short lengths to be combined with other fibers in the manufacture of a variety of materials. When used in reference to the naturally occurring fibers, it denotes quality or fineness, such as "long staple" cotton.

Yarn

Yarns are continuous strands of textile fibers or filaments, in a form suitable for manufacturing textile materials. The strength of the yarn is influenced by fiber strength, size, and length; size of the yarn; and tightness of twist. The strength of textile fabrics is determined by yarn strength and weight. You may form yarn by any of the following processes: a number of fibers twisted together, a number of filaments laid together without twisting, or a number of filaments twisted together. Yarns formed by twisting a number of filaments together are referred to as multifilament (many filament) yarns. Ply yarn is two or more single yarns twisted together.

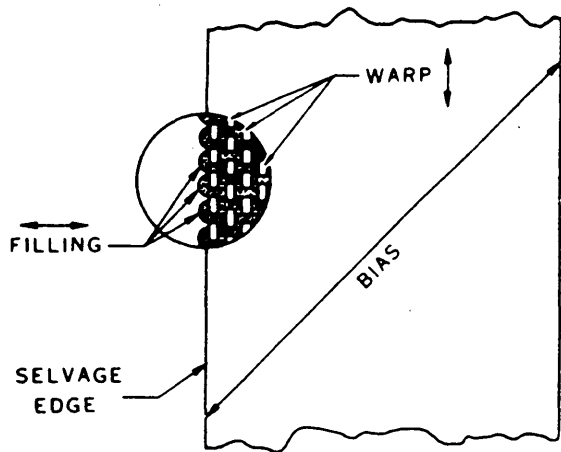

239.367A

Figure 10-1.—Textile terms.

Selvage and Raw Edges

The selvage edges of material, as shown in figure 10-1, are the edges of cloth, tape, or webbing that are woven to prevent raveling. When the material is cut, the resulting edge at the cut is referred to as a raw edge.

Warp

There are threads that run lengthwise of the cloth parallel to the selvage edge. If there is a difference in the strength of the warp and filling threads, the warp threads are usually stronger, because they form the framework for the material and support most of the strain during the weaving process. Figure 10-1 shows both warp and filling threads.

Filling

Filling is also referred to as a *woof*, *weft*, or *pick*. It is the threads that run crosswise to the cloth as it comes from the loom. This term is not to be confused with *filling* in the sense of sizing, which means the addition of substances that give body or decrease porosity of the material. Warp and filling threads must be determined in pattern layout because patterns (unless otherwise stated) are always cut with the warp and filling.

Weave

The weave is an interlacing of two sets of threads (warp and filling) to form a specific

pattern. The manner in which the material is woven or constructed affects many of the cloth properties, such as tensile strength, air permeability, and elongation.

Bias

A bias is a diagonal line of a cut, a fold, or a seam across a piece of textile material at an angle of 45 degrees to the direction of the filling threads in the material. Bias construction is used to save material, prevent tearing between sections, and provide elasticity where it is a requirement for a satisfactory performance of the article. The bias direction of the fabric has a greater stretching quality than the straight direction. A bias cut is shown in figure 10-1.

Tensile Strength

The force required to break a material is called tensile strength. The tensile strength of a fabric is stated in pound-per-inch width for warp and filling. The tensile strength of webbings and tapes is stated for the full width.

Cloth Weight

The cloth weight is the weight of a cloth, or fabric, in ounces per square yard. All fabrics have a designated cloth weight. For instance, a square yard of cotton duck may weigh 8 ounces; therefore, it is called 8-ounce duck.

CONSTRUCTION FEATURES AND USES OF VARIOUS TEXTILE MATERIALS

If a cigar ash burns a hole in your tweed jacket, you will not patch it with a piece of velvet material. If a life raft needs repair, you will not use tweed fabric to repair it. Or, if an NES 12 canopy needs repair, you won't use 7.25-ounce nylon duck. If a repair is to make an item usable, must use like material.

In the not too distant past we were limited to natural fibers as a source for our fabrics and associated materials; but today, with the advent of synthetic fibers, we can enjoy their improvements in some respects over the natural fiber. Currently the natural and synthetic fibers have their respective advantages and disadvantages. Because you cannot use synthetic or natural fiber materials exclusively, you must decide which one best serves your purpose. There

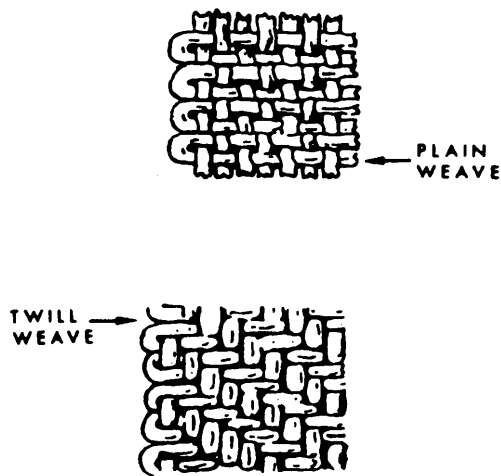

239.367B

Figure 10-2.—Basic weaves.

are many, many different types of fabrics, or cloth. When we say cloth, we mean any textile material over 12 inches wide from selvage to selvage.

The construction of cloth is determined by many factors, such as tightness of yarn twist, number of threads per inch, porosity of the yarns, and the type of weave used in its formation. The weave is one of the most important factors. The two basic weaves are plain and twill (as shown in figure 10-2). The plain weave is the simplest method of weaving and gives the smoothest surface of the fabric. It consists of the filling threads passing over one warp thread and under the next warp thread. The twill weave is a more complicated weave in which the filling threads pass over and under more than one warp thread, thereby producing a surface on the fabric that is generally recognized as a diagonal pattern.

Cotton

Cotton is a natural plant fiber, usually white. The fibers or "staples" are between 3/8 and 2 inches in length. Chemically, it is almost pure cellulose. Cotton fabrics, webbing, and tapes absorb water readily unless treated. They dry more slowly than the synthetic fabrics and are more susceptible to mildew and fungus growth. One should never ignore the presence of mildew because it seriously affects the tensile strength of cotton and other fabrics. Heat is less damaging to cotton than to the synthetics. Insect damage

should, however, always be considered because cotton is a food for certain cellulose-eating insects, and cotton makes good nesting or cocoon-spinning material for rodents and insects.

Nylon

This is a synthetic fiber of extreme toughness and elasticity. It absorbs very little water, dries quickly, is mildewproof, and is not affected by most ordinary oils, greases, or cleaning fluids. It is also mothproof. It is sensitive to some chemical fumes, excessive heat, and direct rays of sunlight. Nylon melts and drips when it is subjected to fire. This characteristic requires that precautions be taken when nylon is worn where there is a risk of fire. Melted nylon on the skin can cause the most serious of burns.

NOMEX Fabric

NOMEX is the trade name for a fabric that is used in the construction of flight suits. NOMEX fabric is a high-temperature resistant and inherently flame-retardant synthetic fabric. This fabric has no melt point or drip characteristics when it is subjected to fire. NOMEX material is light in weight, does not support combustion, but begins to char at 700° to 800 °F. The fabric, similar to nylon, is abrasion resistant, and is also nonabsorbent.

Duck

This is a comparatively firm, coarse, plain-weave, cotton fabric with weight per square yard from 6 to 50 ounces. Duck is frequently called canvas. It is primarily used in the construction of protective covers because of its durability and wearing characteristics.

Rubber and rubberized fabrics are used in the manufacture of exposure suits and flotation equipment because they are watertight. Rubberized materials are susceptible to deterioration if subjected to heat and mildew. Foam rubber is thick and resilient and is used for padding in upholstery and aircraft crash pads.

Leather

Cowhide or horsehide may be used for reinforcing patches where heavy wear occurs. It is used for reinforcing patches for grommets and chafing strips on seat belts. Artificial leather has replaced the natural product, and is used to a large extent for seat pad, crash pad, and upholstery covering.

Vinyl

Vinyl is a plastic material and is used in many instances in the fabric shop. Vinyl is available in various thicknesses, depending on its intended use. It may be used for seat covers or ventilating clothing. The type used for ventilating clothing consists of two layers of flexible vinyl film. Vinyl is vaportight and has a smooth surface. Soap and water can be used to clean it. Do not use ammonia detergents for cleaning because this bleaches the vinyl.

WEBBINGS AND TAPES

You already know that cloth is fabric wider than 12 inches. Any fabric less than 12 inches, from selvage to selvage edge, is called webbing or tape. The dividing line between webbing and tape is determined by the respective weight.

Webbings

The heavier of the two is webbing. Webbing weighs over 15 ounces per square yard and is less than 12 inches wide. As you would expect, webbings are used for the toughest holding and reinforcing jobs. Slings, harnesses, safety belts, reinforcing and securing straps are made of nylon, with a wide variety of tensile strength. The personnel parachute harness has a tensile strength range of 6,000 to 8,700 pounds. Some nylon webbings are of tubular construction, which makes them very strong. Tubular webbings are 1/2 to 1 inch wide, with tensile strengths ranging from 1,000 to 4,000 pounds.

Tapes

In addition to webbings, there are the lightweight tapes of a twill weave construction. You can use tapes for reinforcement on many types of fabric covers. Tapes can weigh up to 15 ounces per square yard. Cloth tapes are woven in the same manner as fabric. Some are bias,

which, because of the bias cut or construction, aid the binding of curved edges where stretching qualities are desired. These bias tapes are sometimes referred to as binding tapes.

Velcro tape is commonly used in many shops as a fastening or closing device. Velcro tape consists of two parts—the hook and the pile or loop tape. The hook tape is made of nylon, which consists of a series of small hooks. The nylon pile or loop tape has many small loops. When the two parts of the tape are joined, the hooks engage with the loops holding the two tapes together.

DIFFERENCE BETWEEN THREADS AND CORDS

The difference between threads and cords is discussed in the following text.

Threads

Filaments (nylon) or staples (cotton) are twisted together to form yarns, and two or more yarns are twisted together to form a thread or ply yarns, as the yarn by itself is too small for practical use. The strength of a thread depends upon the size and number of yarns used to make up the thread. The thread numbers on spools indicate the size of the yarn and the number of yarns that are piled (or twisted) together to give the necessary strength to the thread. For example, a 16-4 thread indicates that the thread was made from a single yarn, size 16, and that four of these single yarns were twisted together to make a thread. The finer the yarn used, the higher its size number. Silk and nylon thread sizes, however, are indicated by letters, such as A, B, etc.; A is finer than B; the farther down the alphabet, the coarser the thread.

Thread is twisted to the left or twisted to the right, depending on its use. Left-twist thread is always used in the sewing machine because the action of the stitch-forming mechanism tends to ravel or break right-twist thread. Left- or right-twist thread may be used for hand sewing. The terms that designate left-twist threads are machine, machine twist, left twist, and Z twist. A cord or thread has left (or Z) twist if, when held in a vertical position, the twist of the yarn follows the slope of the central portion of the letter Z; and right (or S) twist, if it follows the slope of

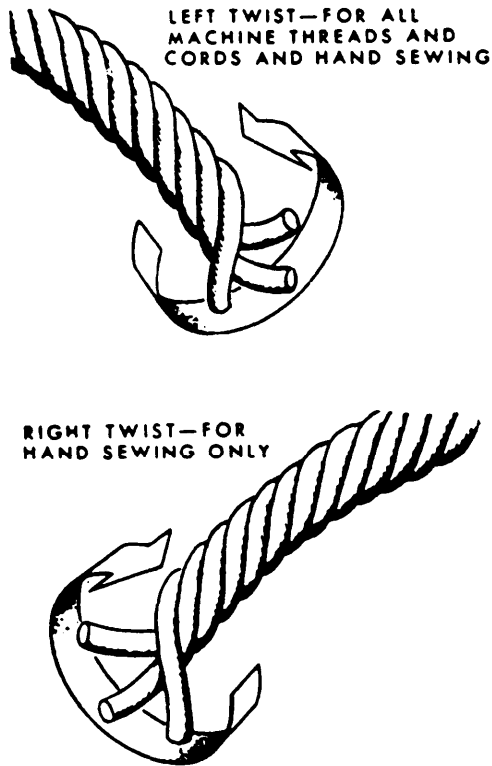

Figure 10-3.—Thread twist.

239.368

the central portion of the letter S, as shown in figure 10-3.

Cords

Unbraided and braided cords are covered in the following paragraphs.

UNBRAIDED CORDS.- Unbraided cord is twisted together in the same manner as thread, as shown in figure 10-3. The difference between threads and cords is that cords are stronger and larger in diameter than threads.

Nylon cords play an important part in the repairing of life support items. To identify nylon cord, you must remember that the larger the number, the larger and stronger the cord.

BRAIDED CORDS.- You know that a braid is three or more strands of material entwined together. Cords also come braided, and in two types: a solid woven cord or a cord with a hollow channel center, as shown in figure 10-4. Solid woven cords are flat. Hollow channel cords sometimes contain several straight, individual

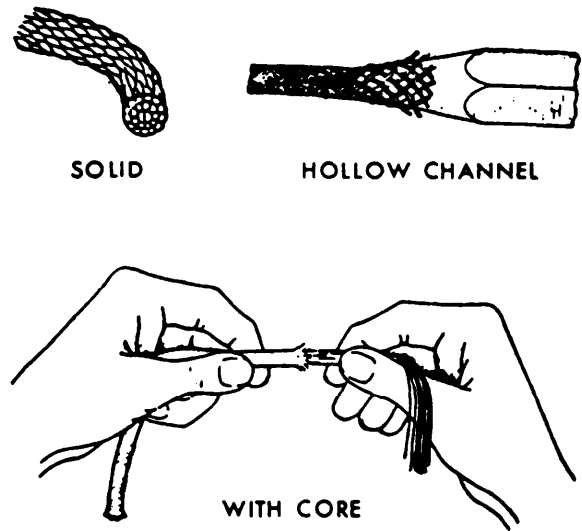

239.369

Figure 10-4.—Braided cords..

threads, known as a core. This core increases the strength of the cord and keeps the outer braided cover round. Parachute suspension lines are made from this type of cord.

STORAGE OF TEXTILE MATERIALS

It is necessary to know the general principles of care and storage of materials because they differ greatly in their resistance to damage such as moisture, heat, mildew, fungus, insects, and rodents. There are certain insects, however, that will eat almost anything; mice build nests in almost any kind of stored fabric material; and there are hundreds of fungus growths that thrive under moist tropical atmospheric conditions. Conditions in various parts of the world vary widely in regard to humidity, heat, or cold, and the presence of insects. Such conditions must be taken into account when you are storing and protecting materials. The following ideal storage conditions should be attained as nearly as possible: a dry room with temperature of 70°F, absence of direct sunlight, a storage room construction that affords protection against insects and mice, wooden shelves for storage, and air conditioning or some other method of humidity control.

Now let's consider some of the characteristics of materials that you should know if you are to be responsible for keeping them in storage. Nylon absorbs very little water, dries quickly, is

mildewproof, and is not affected by most ordinary oils, greases, or cleaning fluids. It is mothproof, and, because it is not an animal fiber like wool or silk, does not offer food to hungry insects. However, if insect larvae develop from eggs laid inside the folds of stored fabrics, they may eat their way out. Soiled or greasy spots in a fabric attract insects.

Soot and certain chemical fumes are highly injurious to nylon, and direct heat and exposure to the sun's rays seriously weaken it.

Rayon has many of the characteristics of nylon. It is more easily damaged by direct heat or the sun's rays and is more combustible than nylon. Rayon fabrics "take a set" (form a crease) more easily than other fabrics, and if left stored in folds for too long, they will form permanent creases.

Cotton fabrics, webbings, and tapes, unless treated, absorb water readily. They dry more slowly than synthetic fabrics and are more susceptible to mildew and fungus growth. Mildew should never be ignored because it seriously weakens cotton or other fabrics. Heat is less damaging to cotton than to the synthetics. Bugs or their larvae will eat cotton or use it to make cocoons or nests.

In all cases, fire is a constant threat to fabrics. Smoking should not be permitted where fabrics are handled or stored. The rayons are almost explosive when set afire. Nylon, although harder to ignite, will bum, but does not explode in the process. You should be careful to learn the storage problems peculiar to any specific locality or climatic conditions to ensure safe storage of these materials.

The construction and characteristics of various fabric products has been explained to give you some basis for the intelligent use and storage of these materials. Besides textile materials, you are required to use dopes, cements, and solvents in the daily performance of your duties as a fabrication and parachute specialist.

ENGINEERING REQUIREMENTS FOR FABRICS

If a parachute is to serve its purpose, it must be reliable. To be reliable, parachutes must meet certain engineering requirements.

At this point you may be wondering why you should be concerned with engineering requirements. After all, you are not designing parachutes. You service parachutes. Here is where the difference shows up between just a parachute

packer and a good parachute rigger. Almost anyone can learn to pack a parachute. But a good parachute rigger needs to understand the 'why' that determines maintenance procedures. When you have learned the engineering and aerodynamic principles that affect parachute reliability, you will know why it is so important to be a conscientious and precise worker. And, you will see to it that those who work for you do their job exactly right. First, the engineering requirements for parachutes are listed and explained below. Then you will learn why the textile most often used in parachute construction is nylon.

Air Permeability

The term *air permeability* refers to the measured volume of air in cubic feet that flows through 1 square foot of cloth in 1 minute at a given pressure. If a material gets wet and shrinks, it has less air permeability, because the weave draws together and less air gets through. This is the reason for that very important rule: DO NOT, FOR ANY REASON, PACK A WET PARACHUTE. Also, a wet parachute assembly can freeze at high altitudes. Air permeability affects the reliability, opening time, opening force, canopy drag, and stability of the parachute assembly.

The proper ratio of air entering a parachute canopy to air passing over the canopy gives a parachute good performance. The greater the airflow through a canopy, the slower the opening time. This is why canopy designs differ. A quick opening time is required for personnel parachutes, but a slower opening time is desired for deceleration and cargo parachutes. The braking force in deceleration and cargo parachutes is built up over a longer period of time, which enables the parachute assembly to withstand and decelerate greater loads.

Strength

The term *strength* refers to a fabric's ability to resist strain or rupture by external forces. Strength is expressed as *tensile strength* (a term you already know) and is measured in pounds per square inch. The strength of the fabric determines the strength of the parachute. Remember the old saying about the chain being only as strong as its weakest link. Strength is a very important requirement for a safe, reliable parachute. Refer to table 10-1 for tensile strengths of fabrics, webbings and tapes.

Table 10-1.—Tensile Strengths

Threads	Tensile Strength	Textile
A	2.75 lbs	Nylon
B	5.50 lbs	Nylon
E	8.50 lbs	Nylon
F	11.00 lbs	Nylon
FF	16.00 lbs	Nylon
Cords		
3	24 lbs	Nylon
6	50 lbs	Nylon
Tubular Webbing		
1/2"	1000 lbs	Nylon
9/16"	1500 lbs	Nylon
3/4"	2300 lbs	Nylon
1"	4000 lbs	Nylon
Webbing		
I 9/16"	525 lbs	Nylon
II 1"	600 lbs	Nylon
III 1 1/4"	800 lbs	Nylon
IV 3"	1800 lbs	Nylon
V 5"	3000 lbs	Nylon
VI 1 3/4"	1800 lbs	Nylon
VIII 1 3/4"	3600 lbs	Nylon
X 1 3/4"	8700 lbs	Nylon
XII 1 3/4"	1200 lbs	Nylon
XIII 1 3/4"	6000 lbs	Nylon
XIX 1 3/4"	10000 lbs	Nylon
Tapes		
II 3/8"	18 lbs	Nylon
II 1"	900 lbs	Nylon
II 2"	1700 lbs	Nylon
III 3/8"	200 lbs	Nylon
III 1/2"	250 lbs	Nylon
III 3/4"	400 lbs	Nylon
III 1"	525 lbs	Nylon
IV 1"	1000 lbs	Nylon
IV 1 1/8"	1100 lbs	Nylon
IV 1 1/2"	1500 lbs	Nylon
VI 3/4"	425 lbs	Nylon
Shroud Line		
I	100 lbs	
III	550 lbs	

Elongation

The term *elongation* describes deformation, lengthening, or stretching caused by a tensile force. It's what you do when you stretch a rubber band. The ability to elongate gives stretch to a fabric. Elongation is expressed as the percentage of stretch over the original length. For instance, if a tape has 10 percent elongation, a 10-inch piece will stretch to 11 inches before it breaks. Parachute specifications call for 20-25 percent elongation.

Elasticity (or Elastic Recovery)

The term *elasticity* describes the ability of a fabric to elongate (or stretch) when tension is applied, and to recover its original shape when the tension is released. If you stretch a rubber band and then let it go, it comes back to its original size. To test the elasticity of a material, stretch it 4 percent and then measure to see how closely it returns to its original length. A fabric that returns to within 75 to 95 percent of its original length after being stretched is said to

have satisfactory elasticity. A parachute made from fabric with good elasticity is stronger and gives less opening shock.

Weight

Lightweight fabric is an absolute necessity for all parachute canopies. A canopy of lightweight material opens faster. Can you imagine a pilot walking around wearing anything as heavy as a canvas beach umbrella? Lightweight cargo and deceleration parachutes enable the aircraft to carry more weight in cargo and fuel.

Resistance to Abrasion

This refers to a fabric's ability to withstand wear and rubbing. In its lifetime, a parachute is subjected to a great deal of abrasion. When you pack a parachute, you pull the canopy down the table. A deceleration parachute slides along the runway. For this reason, deceleration parachute riser webbings and personnel parachute harnesses and risers are treated with Merlon (brand name) to make them more resistant to abrasion damage.

Resistance to Mildew and Insects

Moths and other insects love to feast on fabrics; mildew and other fungi thrive on them in warm, damp climates. Parachutes damaged by mildew or insects would be unsuitable for Navy use. Therefore, it is necessary that parachute fabric be as resistant as possible to this type of damage.

Moisture Regain

The term *moisture regain* refers to the percentage of moisture that a bone-dry fiber absorbs from the air under standard conditions of temperature and humidity (65 percent relative humidity and 70 °F). Less than 5 percent moisture regain means that the fibers build up static electric charges when rubbed. If static electricity builds up, the parachute assembly is more difficult to service. Static electricity also adversely affects the opening time of a parachute assembly.

The ability to take on dye (color) is another important consideration when selecting parachute fabrics. The percentage of moisture regain possible in a fabric determines whether it can be successfully dyed. Dyeing gives the fabric color, which is important for a parachute canopy. Rescue teams can easily spot multicolored

canopies from the air. Pickup crews can quickly identify colored deceleration canopies on runways. Also, yellow dye in a canopy makes it more resistant to ultraviolet damage from sunlight, which relates to the next engineering requirement on this list.

Resistance to Sunlight

Ultraviolet light, which is found in sunlight, reduces the strength of fabrics. Ultraviolet rays give you a painful sunburn when you're out on the beach too long. All parachutes are exposed to some sunlight. Military specifications for parachute materials state fabrics should not lose more than 25 percent of their original strength after 50 hours exposure to sunlight. Investigations into causes of deceleration parachute failures have shown strength loss of more than 50 percent after 50 hours of exposure to sunlight.

Resistance to Heat

In addition to sunlight, heat and friction are natural enemies of a parachute. In case of fire on an aircraft, personnel and deceleration parachutes may be exposed to great amounts of heat. Friction and heat are generated when the deceleration parachute comes in contact with the runway. Line-overs cause friction and burn holes in parachute canopies. Line-overs happen when an improperly stowed suspension line is drawn over the canopy during deployment.

Resistance to Chemicals

Because parachute assemblies are exposed to various chemicals, it is important to know which chemicals are harmful and which are not. Most damaging are mineral-type acids, such as the type used in batteries.

You have studied a long list of engineering requirements that are important to know when you service parachutes. You already know that nylon is the most widely used fabric in the parachute shop. In the following text, we examine the good and bad characteristics of nylon in parachute construction.

There is no fabric known to man that measures up perfectly to all the engineering requirements for parachute construction. But nylon comes closer, by far, than any other fabric. Nylon, when properly handled by the parachute

rigger, has more good than poor qualities. First, we will review the good characteristics of nylon:

1. Strength. Nylon is one of the strongest synthetics made.
2. Elongation. Nylon stretches from 18 to 40 percent, which is well above military specifications of 20 to 25 percent.
3. Elasticity. Nylon returns to 100 percent of its original length.
4. Weight. Nylon fibers are very strong for their weight; therefore, the fabrics manufactured of nylon fibers are lightweight fabrics.
5. Resistance to abrasion. Nylon doesn't have enough resistance to last forever under all the rugged use parachutes get, but it is better than any other material tested for parachute use.
6. Resistance to mildew and insects. Nylon has no food value. This makes it unappetizing to moths and other insects. It cannot support the growth of mildew. This isn't true, however, when a cup of coffee is accidentally spilled on a parachute assembly, or other edible foreign matter comes in contact with it. What we really mean is clean nylon has no food value.

We warned you that nylon is not the perfect fabric. Where possible, improvements have been made in manufacturing nylon. The limitations you must keep in mind when handling nylon are as follows:

1. Moisture regain. Remember, we said that if the percentage of moisture a fiber absorbs from the air is less than 5 percent, the fiber is difficult to dye and builds up static electricity when rubbed. The moisture regain of nylon is only 4.2 percent, so you can expect static electricity to develop as you service the assembly.
2. Resistance to sunlight. We mentioned earlier that yellow dye improves resistance to ultraviolet light damage. That is why yellow dye is added to deceleration canopy material. In addition, a chemical known as Chemstrand "R" has been developed, which, when added to nylon fiber as the yarns are manufactured, makes nylon more resistant to ultraviolet light.
3. Heat resistance. Nylon has a relatively low melting point, 482 °F, which makes it very susceptible to damage from heat. This is why it is so important that suspension lines be stowed properly. In the rapid deployment sequence, lines crossing each other will break from the friction heat generated.

In short, there are several natural enemies to be aware of when you handle parachute textiles of any type. These are the hazards of sunlight, abrasion, heat, chemicals, insects, and fungi on parachute components.

Keep in mind the natural enemies of textiles you have learned. Then it is easy to see which elements are to be avoided when you store parachute fabrics.

SPECIAL HAND TOOLS

When working in the fabric shop, you will find that you have a need for tools that are not commonly stocked in the average tool room. Therefore, we must discuss some of the specific tools used in the fabric shop. The tools used for fabric and rubber maintenance are not highly complicated, but they are designed for a specific purpose. In your hands these tools can help produce a finished product of which you can be proud.

SHEARS

A scissor-type tool that you often use for fabric work is known as shears, as shown in figure 10-5. A pair of shears consists of two cutting edges so hinged that, when closed, the cutting edges cross each other in close contact. This shearing action is used for cutting fabrics. The large loop in the handle is for two or three fingers and the small loop is for the thumb. The blades are not straight, but are slightly curved toward each other so that, inclosing, the two cutting edges are held firmly together by the spring action of the blades.

Always keep the shears sharp. If the shears are not sharp enough to effectively cut the material, they must be sharpened. A more

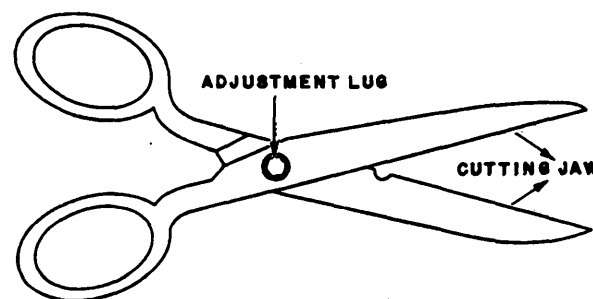

239.370

Figure 10-5.—Shears.

effective job can be done by disassembling the shears and sharpening one shear at a time. The bottom shear has a more blunt angle than the upper, so exercise care in the cutback or angle of sharpening. Also in sharpening, start at the point or toe of the shear and move toward the heel of the shear. This drives the heat, generated in grinding, to the heel of the shear where there is more metal to radiate the heat. To grind toward the toe or point drives the heat to the lesser metal, and it can result in burning the metal and drawing the temper out. After grinding the shear, reassemble it loosely at first so that, on the first closing, the wire edge resulting from the grinding is removed.

Another type of shears you will use is known as pinking shears. This tool is used for cutting a series of Vs along fabric edges to prevent fraying. If pinking shears become dull, they should be returned to the manufacturer for sharpening.

Remember, always keep the shears sharp. Don't drop your shears, as this springs the blades and reduces their cutting ability. DON'T use them to puncture metal objects or to pry things open. DON'T use shears as a knife to remove stitching; you may injure yourself or damage the stitches you are cutting. (For this job, use an upholsterer's knife or a stitch cutting tool.) When shears are beyond shop maintenance capabilities, return them to supply for a replacement.

FOOT-OPERATED GROMMET PRESS

With the foot-operated grommet press, as shown in figure 10-6, you can install grommets by mass production. The press itself stores the two parts of the grommet, leaving your hands free to position material while your foot applies the needed pressure. The important parts of this press are the chuck and die. For each type and size of grommet, there is a corresponding chuck and die. The chuck is the upper tool; the die is the lower tool. Use the adjustment screw, located either at the top or bottom of the foot-operated press, to prevent pressure damage to the chuck and die. When set correctly, this adjustment screw will set the clearance of the chuck and die to 1/32 inch, about the thickness of bond typing paper, which is adequate for most grommets. Some foot-operated presses have been in service for as many as 25 years and still require only the replacement of the chuck and die. The foot press may also be used in the shop to install glove fasteners. However, if a portable glove fastener installation tool is needed, you can use the hand press.

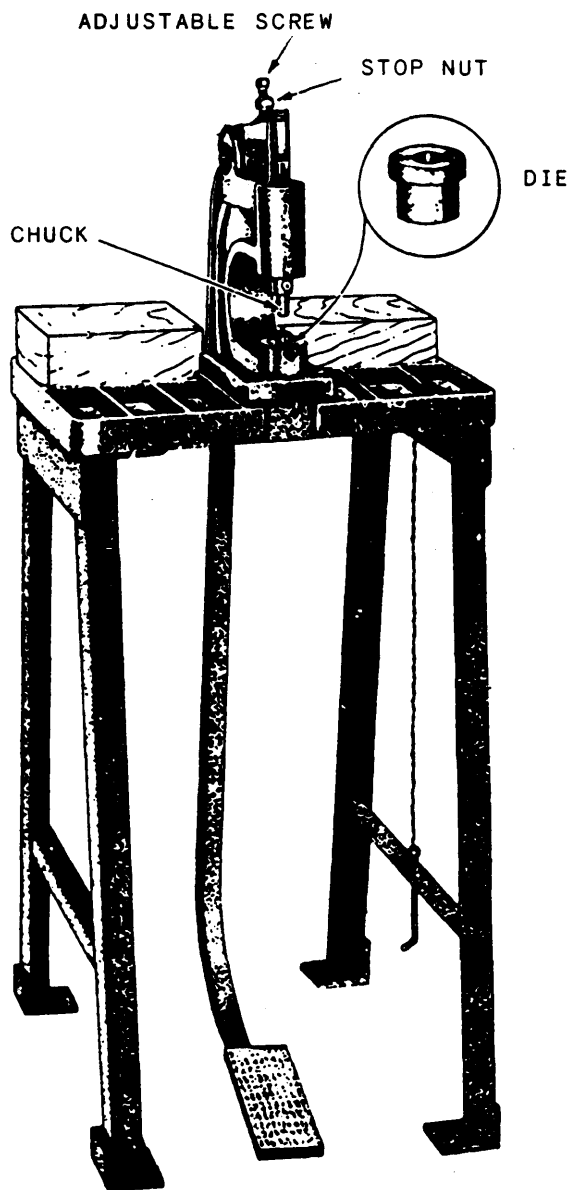

Figure 10-6.-Foot-operated press.

HAND PRESS

The Durable Fastener hand press, as shown in figure 10-7, mates the two female portions of the fastener (socket and button) and the two female portions (stud and eyelet). You will use this often as you replace Durable Fasteners on soundproofing, cushions, or other related items where a portable installations tool is required.

KNIVES

A knife, because of its familiarity, can be one of the most abused tools. At its best, a knife has

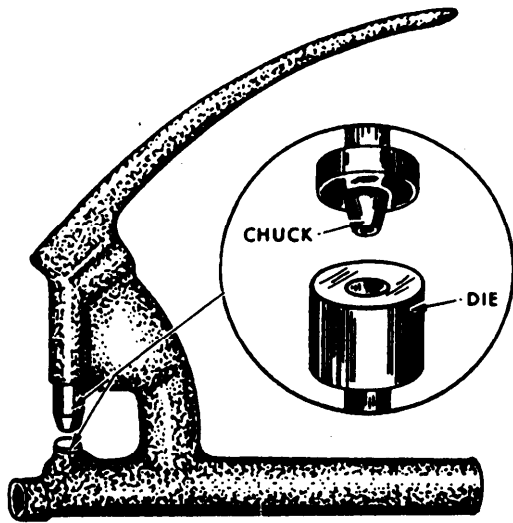

Figure 10-7.-Hand press.

239.372

a well-sharpened blade and a secure handle. DON'T use any knife as a screwdriver, a punch, or a pry to open can lids. Always cut away from you, and keep your hands out of the way of the blade.

To sharpen a knife, use an oilstone and apply the same basic principle as that used for sharpening shears. Do NOT sharpen a knife blade on a grinding wheel because the metal is too thin. Too much heat is generated for the thickness of the metal. To sharpen a knife, clean the oilstone of all gum and dirt accumulation. Put two or three drops of medium-light oil on the stone. Lay the knife on the stone with the back of the knife slightly raised. Draw the knife toward you with a diagonal stroke from heel to toe with the cutting edge advancing. Turn the knife over and move the blade away from you, cutting edge advancing, moving from heel to toe. Repeat these steps several times. The edge is sharp if you feel a decided drag when passing it lightly over a wet thumbnail. No drag indicates the edge is not sharp.

MEASURING DEVICES

The ruler, tape measure, and carpenter's square, as shown in figure 10-8, are used often during the repair of fabric and rubber articles. These may become special tools by adding a special mark to show a commonly used scale or measurement. To comply with technical directive specifications, be sure to exactly measure items

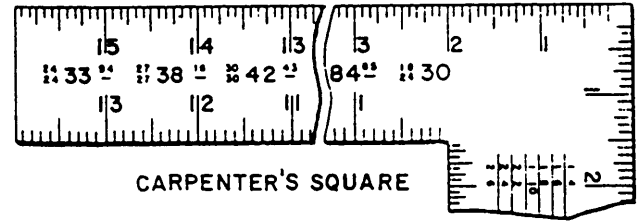

CARPENTER'S SQUARE



RULER

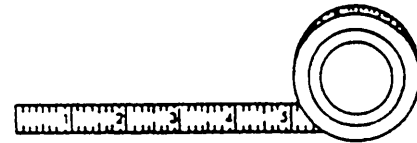

TAPE MEASURE

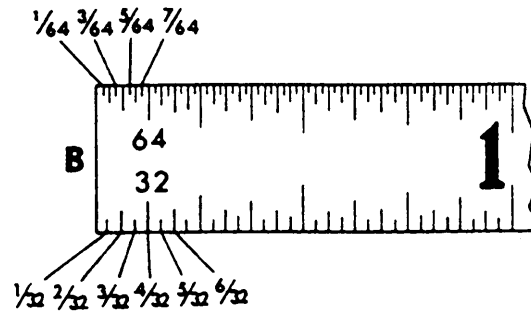
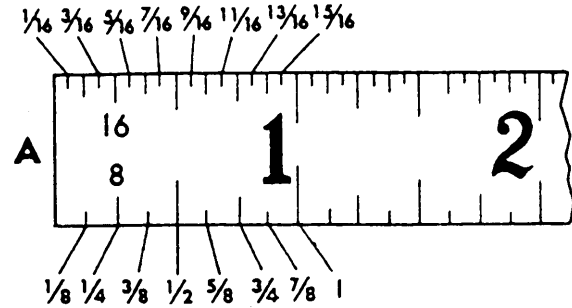

239.373

Figure 10-8.-Measuring devices.

such as the patch overlaps, length of lines on life rafts, and every other job you do that requires special measurements.

The 12-inch, plain steel rule is used for laying out and measuring small work. One side of the rule, shown in view A of figure 10-8, has one edge graduated in sixteenths of an inch and the other edge graduated in eighths of an inch. This is indicated on the rule by the numbers 16 and 8, which are stamped into the metal. The opposite

side of the same rule may have one edge graduated in sixty-fourths of an inch and the other edge graduated in thirty-seconds of an inch, as shown in view B of figure 10-8.

The carpenter's square is a steel tool in the form of a right angle. One arm is 24 inches long, and the other is 18 inches long. It is used by the carpenters to lay out the framework of buildings and to square off wood materials. The fabrication and parachute worker uses it for layout work and measuring.

The tape measure is a convenient tool. It is used to measure large objects, yet it is portable and can be carried in a pocket. The tape measure is flexible and allows you to measure curved objects. These measuring devices (ruler, tape measure, and carpenter's square) are used to achieve accurate and professional results.

SAILMAKER'S PALM

The sailmaker's palm has a small metal disk insert set in rawhide and stitched into a leather glove-type device. It is designed to be worn in the palm of the hand, and it is used to aid in pushing a sail needle through the material being sewn or tacked (fig. 10-9).

AWL

The awl is another instrument used as an aid in sewing heavy material where pushing the sail or hand sewing needle through the material becomes difficult. It is a sharp-pointed instrument, with a handle attached, and is used for punching holes in a heavy fabric or material prior to inserting the needle. Never use a hot needle or iron as a substitute for the awl.

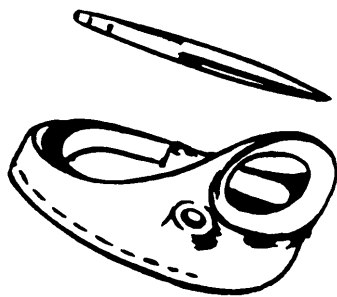

Figure 10-9.—Sailmaker's palm.

STAR PUNCH

The star punch or leather punch is a very useful tool for punching holes through material to be fastened with snap fasteners or speedy rivets.

HARDWARE

Looking back through the first two sections of this chapter, you see that we have discussed textile materials and tools. This section is also concerned with a different type of material often used in the fabric shop. We call it hardware. Grommets, glove fasteners, and interlocking fasteners are pieces of hardware you use during your daily work. You must install pieces of hardware to covers, bags, and clothing to strengthen or to secure these items. Not only do you have to be able to identify this hardware, you also have to know how to install it properly.

GROMMETS

You use grommets whenever it is necessary to reinforce holes for lacings in covers, bags, panels, and upholstery. There are two parts to a grommet: the grommet itself or collar and the washer. The two types of grommets used are plain and spur grommets, as shown in figure 10-10.

The plain grommet uses a plain washer, whereas the spur grommet uses a toothed washer that bites into the material to form a grip. The spur grommet, because of its strength, is used where the pull will be particularly strong; or it may be used in large covers. Leather is sometimes used at corners to reinforce the area where grommets are to be installed. Grommets are made of aluminum, brass, or chrome-plated brass. They are available in several sizes (00, 1, 2, 3, 4, etc.);

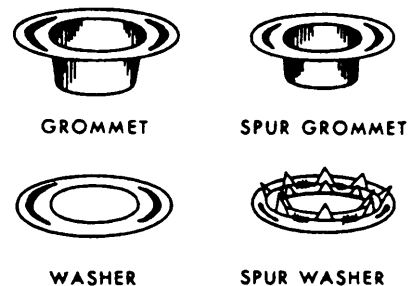

Figure 10-10.—Grommets—plain and spur. 239.304A

the smaller the number, the smaller the size of the grommet.

To install grommets, you must proceed through a series of operations. Locate and mark where a grommet installation is needed. Be sure you set the grommet far enough from the edge of material to prevent it from tearing. Select the correct punch by matching its size to the size of the grommet collar, as shown in figure 10-11.

After you have used the leather cutting punch to cut a hole in the fabric, you must mate the parts of the grommet. Place the grommet on the finished side of the material and the washer underneath. Determine the correct size chuck and die. Assemble the grommet, washer, punch, and die, as illustrated in figure 10-12. Now you are ready to flatten the collar. This operation can be accomplished in a variety of ways, depending upon the availability of tools.

Grommet Press Installation

You may have a foot-operated grommet press or a hand press, as illustrated in figures 10-6 and 10-7. To use either type of press, you need an assortment of chucks and dies. Install the die in the bottom of the press and the chuck in the top of the press. Set the foot press and check for a clearance of the thickness of heavy paper between the chuck and die. This prevents damage by striking the chuck and die together. By depressing the foot pedal or handle, you securely flatten the grommet.

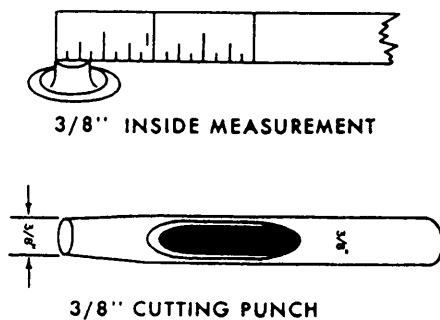

239.374

Figure 10.11.—Inside diameter measurements.

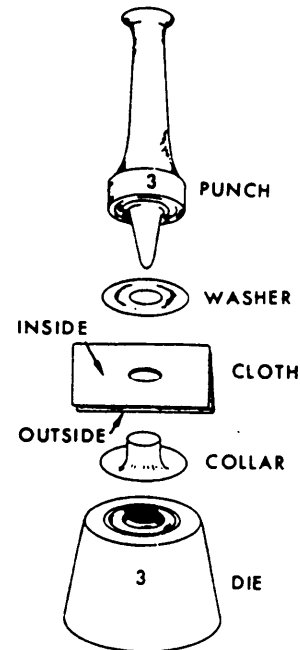

239.375

Figure 10-12.—Grommet collar, cloth, and washer in grommet set.

Grommet Set Installation

A grommet set, consisting of a punch and die, is used to install grommets in material. Figure 10-12 illustrates a grommet set. The grommet set has to be the same size as the grommet for a proper grommet installation. Use a rawhide mallet to strike the punch. This action flattens the grommet. The grommet set installation is used because of its simplicity and portability.

GLOVE FASTENERS

The most common type of fastener used on clothing and other items made of fabric and rubber is the glove fastener. In many instances, the glove fastener has replaced the conventional button. Glove fasteners are dependable and are used for their holding and firm gripping ability. Figure 10-13 shows the three different types of glove fasteners most commonly used. The main difference between the three fasteners is size. The Segma Dot is the smallest; the Durable Dot is the largest type of glove fastener. Each fastener is made of four parts: button, socket, stud, and

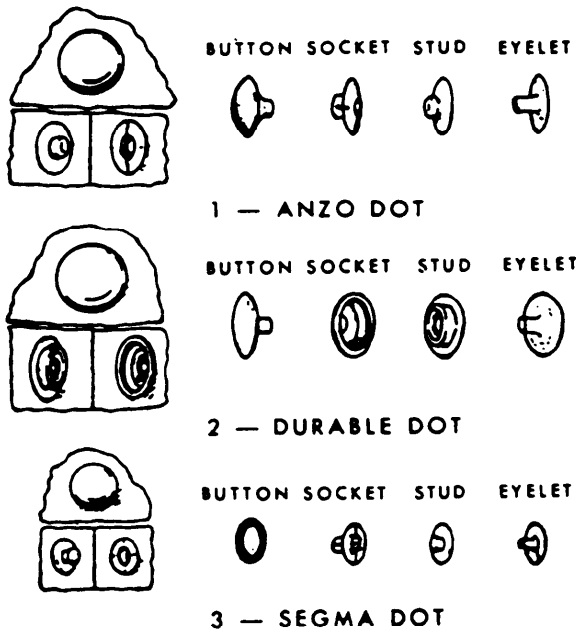

239.377

Figure 10-13.—Glove fasteners.

eyelet, as illustrated in figure 10-13. The socket and button are matched to form the snap. The stud and eyelet form the part to which the socket and button snap.

Press Installation

Cut a hole the size of the collar of the button and insert the button in the material. Place the correct chuck and die into either a foot-or hand-operated press, as shown in figures 10-6 and 10-7. The die is the lower and the chuck is the upper tool, as shown in figure 10-14. Fit the socket to the chuck, as shown in figure 10-14. Lay the button in the die and complete the attachment by depressing the handle or foot pedal. Cut the proper size hole in the material to receive the eyelet. Place the correct chuck and die in the press. Insert the collar of the eyelets through the hole from the back of the material. Fit the stud into the chuck. Lay the eyelet on the die and complete the attachment.

Hand Installation

Cut a hole the proper size for the collar of the glove fastener button. Insert the button in the material and place the socket over the collar of the button. Make an indentation in a wooden

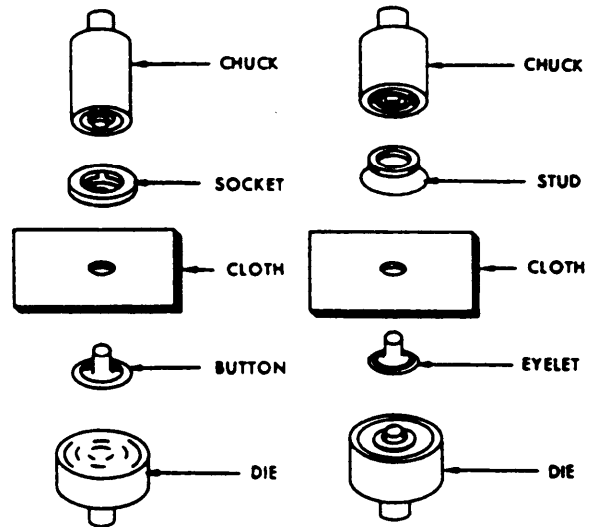

239.303A

Figure 10-14.—Durable dot fastener installation.

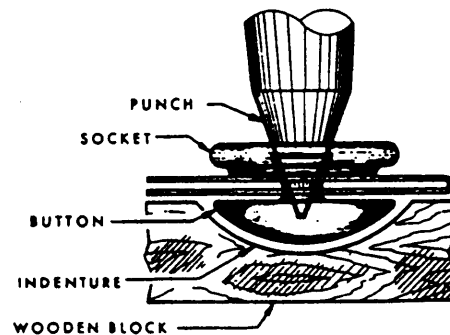

239.378

Figure 10-15.—Flaring button collar.

block for holding the head of the button. Flare the collar of the button slightly with a center punch, as shown in figure 10-15. Flatten the collar of the button with a solid drive pin punch. Assemble and install the stud and eyelet on the other pieces of material so the base of the eyelet is on the backside of the material. Flare and flatten the collar of the eyelet in a manner similar to the installation of the button and socket.

THREE-WAY LOCKING FASTENERS

There are times when you need to use a snap fastener that has extra security. When you must have this type of fastener, you should use either the three-way locking snap or the curtain fastener.

THREE-WAY LOCKING SNAPS

The three-way locking snap is stocked in one size only—regular. It is used on fight clothing,

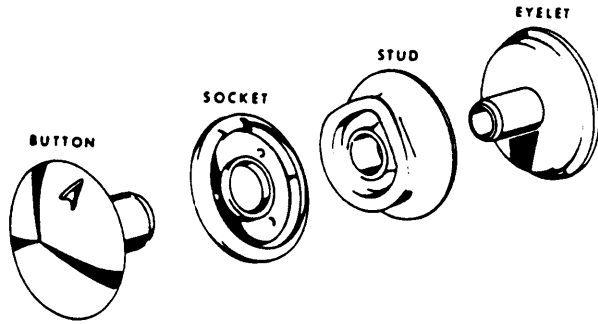

239.298

Figure 10-16.—Three-way locking snap-type fastener.

parachute containers, and back pads. (See figure 10-16). This fastener opens only when lifted from the side, with the dot located on the top of the button. When installing this snap fastener, you should ensure that you install the three-way locking snap in the position that you want to be opened. This type of snap should never be used where any quick-opening devices or quick-releasing action is required.

CURTAIN FASTENER

The curtain type fastener (lift-the-dot) is stocked in two sizes—large and small. (See figure 10-17). These fasteners have many uses, especially for truck and boat covers. The small lift-the-dot is the same as the large one, and designed on a smaller scale for use on lighter work where the bulkiness and weight of the large lift-the-dot are not desired.

INTERLOCKING SLIDE FASTENERS

Tasks are accomplished more easily and quickly through the use of interlocking fasteners. For example, they save precious seconds for an aircrewman when he is donning his flight clothing or exposure suit. These fasteners also provide the repairman with a means of easy access to items that require inspections.

The types of interlocking slide fasteners (zippers) used on flight clothing and other items of aviation equipment are shown in

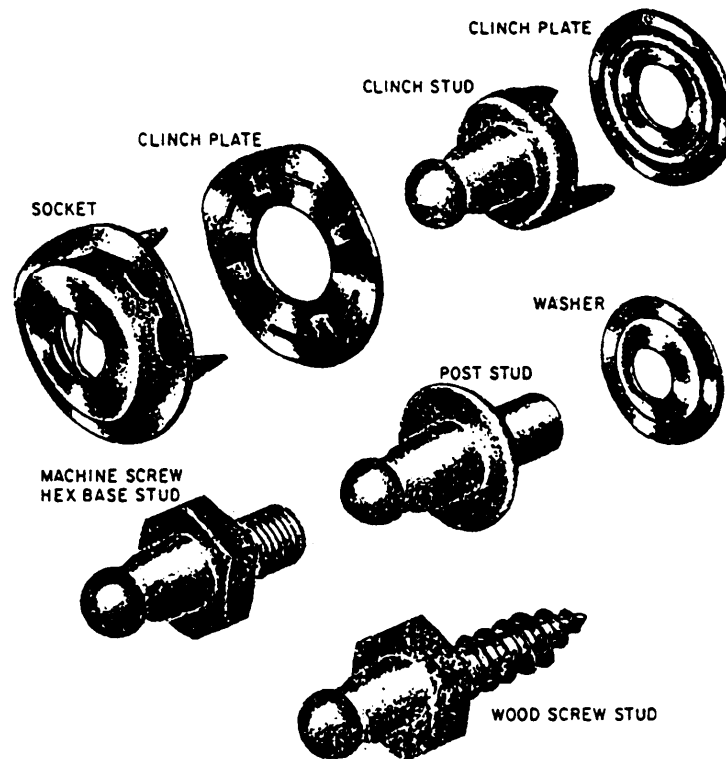

239.299

Figure 10-15.—Large curtain-type fastener (lift-the-dot).

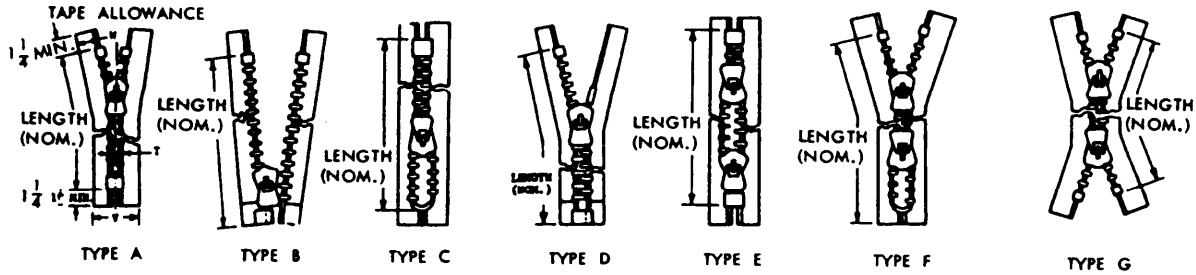

TYPE A - NON-SEPARATING, SINGLE ACTION.
 TYPE B - SEPARATING, SINGLE ACTION.
 TYPE C - NON-SEPARATING, SINGLE ACTION WITH BRIDGE STOP.
 TYPE D - SEPARATING, SINGLE ACTION, QUICK DETACHING.
 TYPE E - NON-SEPARATING, DOUBLE ACTION, CENTER OPENING.
 TYPE F - NON-SEPARATING, DOUBLE ACTION WITH BRIDGE STOP.
 TYPE G - SEPARATING, DOUBLE ACTION, END OPENING.

SIZE 0 - LIGHT SERVICE.
 SIZE 1 - LIGHT-MEDIUM SERVICE.
 SIZE 2 - MEDIUM SERVICE.
 SIZE 3 - MEDIUM HEAVY SERVICE.
 SIZE 4 - HEAVY SERVICE.

STYLE S - STANDARD NON-LOCKING.
 STYLE L - LOCKING.

239.307

Figure 10-18.—Slide fasteners.

figure 10-18. Figure 10-19 shows the parts of an interlocking fastener.

Interlocking Slide Fastener Construction

An interlocking slide fastener consists of two chains of teeth (hollow cones or scoops) facing each other. When brought together at the proper angle, each tooth fits within the scoop of the tooth opposite it.

When closed, the interlocking slide fastener teeth cannot be parted except through the use of

the slider, which, when moved, displaces teeth at the proper angle for meshing and unmeshing. The small clips (stops) at the top and bottom of the interlocking slide fastener are designed to prevent the slider from running off the track. Separating-type slide fasteners do not have a bottom stop, but are equipped with a pin on one side and retainer arrangement on the other to allow the two parts of the slide fastener to separate.

Interlocking Slide Fastener Operation

Ordinary interlocking slide fasteners are designed for flat, smooth operation. Both hands are required for proper functioning. The chains should be stretched taut with one hand and the slider worked (without force) with the other.

When operating an interlocking slide fastener installed in a garment of soft nappy material, or lined with wool or fur, do so with care to prevent the nap or wool from jamming the slider.

Very often grease or oil deposits lodge between the tiny hollow parts of the teeth and accumulate dirt and lint. This causes stiff operation of the slider. A dirty or gummed chain should be cleaned with an old toothbrush or a pipe cleaner saturated with Stoddard solvent or other similarly approved cleaning solvent. After each cleaning, the chain should be lubricated by applying one drop of oil or a small amount of graphite between your thumb and forefinger and running the chain up and down between your fingers several times.

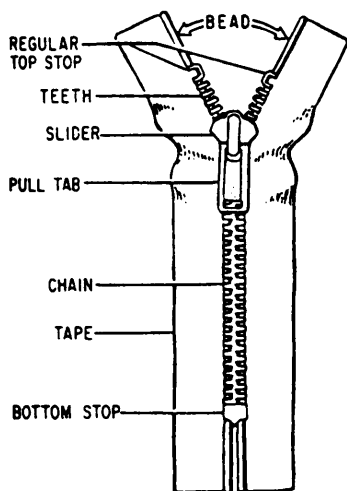

239.308

Figure 10-19.—Slide fastener parts.

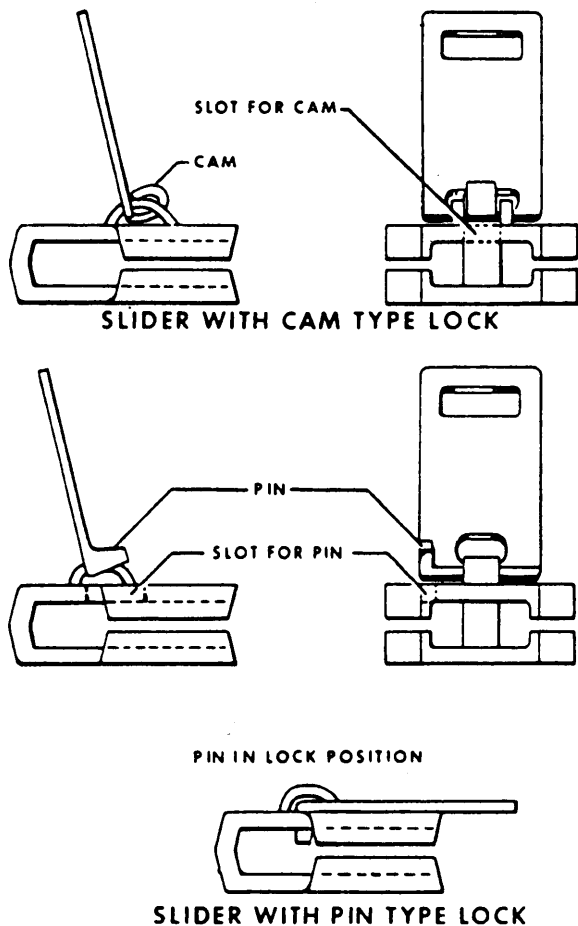

239.309

Figure 10-20.-Slide fastener pull tabs.

A brief inspection will determine whether a slider (or pull tab) is the locking or nonlocking type. Always be certain that the pull tab is lifted at right angles to the slider before attempting to remove the locking type. The relative positions of the pull tabs are shown in figure 10-20.

Interlocking Slide Fastener Tools

In addition to common tools such as screwdrivers, pliers, awls, knives, scissors, and needles, a well-equipped slide fastener kit should be included in the parachute loft equipment.

The interlocking slide fastener kit (zipper repair kit) contains all the parts necessary to repair any size or type of interlocking slide fastener, plus the following special tools: end cutters, or nippers, used for removing stops and teeth; stop-closing pliers, specially designed to span over the slider and clamp the stops in position; and pull-up pliers,

designed to close the slider without a pull tab. Another handy tool in slide fastener repair is an awl with a bent tip. This tool maybe used to close the chain by hand.

Interlocking Slide Fastener Repair

A torn or ripped interlocking slide fastener bead cannot be repaired, but should be replaced with a complete new interlocking slide fastener. If the bead is damaged near the top or bottom of the interlocking slide fastener, and the damaged ends can be cut off to shorten the interlocking slide fastener without hampering the usefulness of the garment, an effective repair can be made.

Loose or missing teeth and stops can cause trouble. If teeth or stops are not tightened, they will eventually be lost and tear the bead. In repairing such damage, see that the loose stop is in position (almost touching teeth), and then set tightly with stop-closing pliers. Set any loose teeth parallel with the other teeth in the chain, and then apply pressure with the stop-closing pliers. Set any loose teeth parallel with the other teeth in the chain and apply pressure with the stop-closing pliers. If a replacement stop is not available in the repair kit, a soft wire or heavy thread may be used as a temporary stop.

A missing tooth should be repaired by replacing the entire interlocking slide fastener. However, in the event that there are no spare fasteners available, a missing tooth may be replaced. This is done by carefully removing the stop from the top of the chain, taking off the top tooth, replacing the stop, and setting the tooth in place. (You should be careful not to damage the bead of the chain when resetting the tooth.)

You may run into trouble in moving the slider on the chain. This is caused by the jaws of the slider being too tight, or a dirty chain maybe the trouble. To loosen the slider, insert a screwdriver between the jaws, and very gently pry them apart until they operate freely.

Should the slider become jammed with fur, wool, or other material, carefully remove such matter with a pin or needle while gently pulling the slider until it is released. If it is so badly jammed that it resists all efforts, remove the slider by carefully bending the jaws apart and returning the jaws to their original position. Then replace the slider on the chain (described later).

Most pull tabs have two small projections fitting into slots on each side of the slider. To remove the pull tab, use two pairs of pliers, one on each side, and twist in opposite directions. In

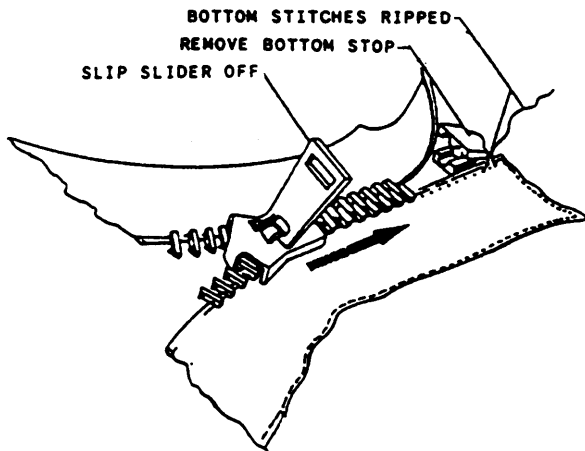

239.310

Figure 10-21.—Removing the slider.

replacing pull tabs, this procedure is reversed. Pull tabs furnished as replacements need only to be squeezed onto the slider.

To repair a damaged slider, you must first remove it. The proper procedure for removing and replacing a slider on the chain following repairs is explained in the following paragraphs.

To remove the slider from the regular type interlocking slide fastener (nonseparating), carefully rip the stitches from the **BOTTOM** of the interlocking slide fastener to expose the ends of the tape. Then remove the bottom stop, and slip the slider off the bottom of the chain and entirely off the beads and tape, as shown in figure 10-21.

To replace the slider on a regular type interlocking slide fastener, thread the two bottom beads into the wide end of the slider. Hold the tape so that the bottom teeth are correctly matched; then draw the slider upward until the teeth mesh for several inches. Without allowing the teeth to separate, clamp the bottom stop close to the teeth and over both beads. Replace the tape ends and ripped stitches by hand or by machine.

To remove a damaged slider on a separating type slide fastener, carefully rip the stitches at the **TOP** of the slide fastener, on the retainer side only, thus exposing the end of the tape. Remove the top stop, slip the slider off the top of the chain, and completely remove it from the bead and tape. Repair or replace the slider.

To replace the slider on a separating type interlocking slide fastener, thread the bead on the retainer side into the narrow end of the slider, and allow the slider to slip down the chain. Replace

the tape end and ripped stitches by hand or machine.

To replace the slider on the top of a regular, nonseparating type interlocking slide fastener with the aid of pull-up pliers, slip the tool over the bottom stop, clamp together, and pull upward. Close the entire chain in this manner. Thread the two top beads into the narrow end of the slider, holding the teeth meshed until they enter the slider. Replace the top stops, tape ends, and ripped stitches.

Shortening an Interlocking Slide Fastener

To shorten an interlocking slide fastener, first determine the length required. The chain should be about one-half inch shorter than the opening in the material or garment. Mark the desired length, measuring from the bottom stop upward. Open the chain to any point below this mark and cut directly across the tape about 1 inch above the mark. Cut the excess teeth from the marking point to the end of the tape, and replace the two stops, crimping them firmly.

Installing an Interlocking Slide Fastener

The installation of an interlocking slide fastener varies with the type of job. Some are curved, some have rounded comers, and some are hidden. The installation of a straight slide fastener is described in the following paragraphs.

Slide Fastener Presser Foot

To install a slide fastener neatly and easily, you should use a slide fastener presser foot on the sewing machine. The slide fastener presser foot serves not only as a guide for a neat row of stitches, but also prevents the foot from riding up on the chain.

The sewing machine manufacturer can supply a regular slide fastener presser foot (right or left) for any sewing machine, or one can be made locally. File or grind the left side of an old presser foot to permit sewing to within 1/8 inch of the chain.

Fabrication

When sewing, always stretch the slide fastener and not the material, as this makes a flatter and neater job.

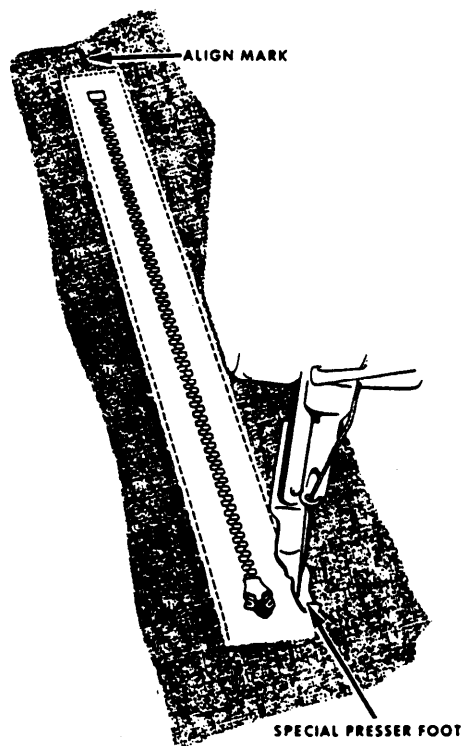

239.311
Figure 10-22.—Installation of a slide fastener. Step 1.

When making a bag or cover with two closed ends, lay the piece of material right side down, and place the slide fastener right side down on top of the material where the opening is to be located. Sew a row of stitches completely around the outer edge of the tape, as shown in figure 10-22.

Turn the material over. Then by feeling with the points of a pair of scissors, cut the material directly down the center of the chain and cut a V at each end, as shown in figure 10-23.

Turn the edges of the material under, thus exposing the chain. Allow sufficient space between the chain and the folded edge of the material to prevent the slider from rubbing the edge of the hems. Cutting the V at each end of the chain permits the sewing of neat, square corners. (See figure 10-24.)

Procurement of Slide Fasteners

When requisitioning slide fasteners or slide fastener parts through the supply system, certain specific information is necessary: type, size, grade, color, style or slider, and unit of issue are all part of this information.

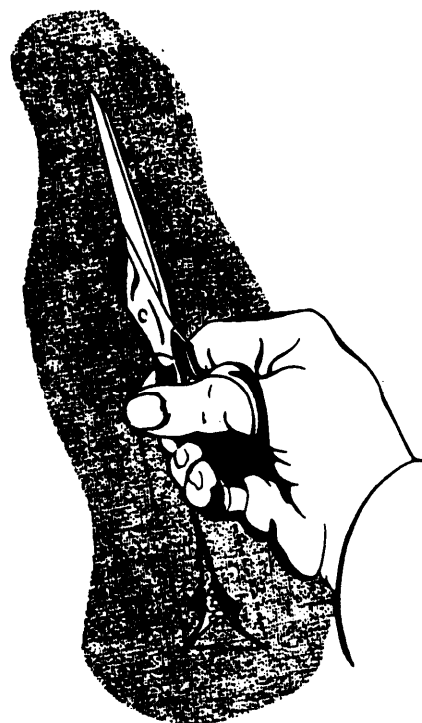

239.312
Figure 10-23.—Installation of a slide fastener. Step 2.

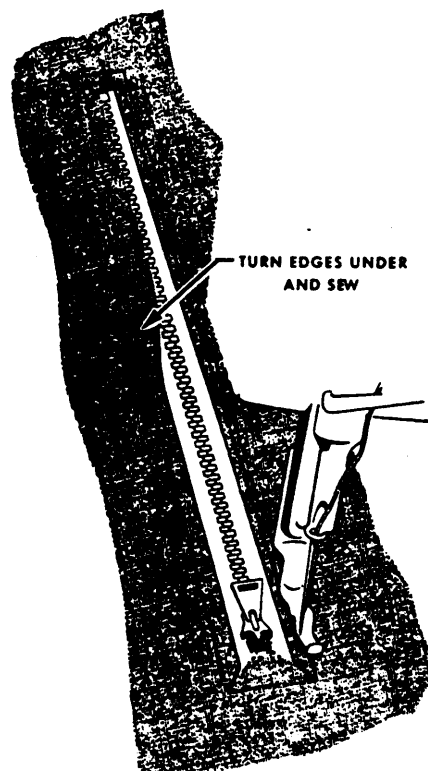

239.313
Figure 10-24.—Installation of a slide fastener. Step 3.

There are two types of slide fasteners—separating and nonseparating. A nonseparating, type A, slide fastener is used where only a small area needs to be opened; for example, the opening in a parachute bag. A separating slide fastener, type B, is used in areas where it is necessary to spread the opening for easy access, such as on a jacket or the legs and waist of an anti-g coverall.

To determine the size or service weight of a slide fastener to be installed on a fabric assembly, consider the weight of the material and the stress that will be applied. The size range and services of slide fasteners are as follows:

1. Size 0 - light service
2. Size 1 - light to medium service
3. Size 2- medium service
4. Size 3- medium to heavy service
5. Size 4- heavy service

Materials used in slide fastener construction vary from plastic and nylon to cotton, rubber, and metal. There are two common grades of slide fastener chains. Grade I is of brass construction and Grade II is made of other metal alloys or synthetic materials.

In most instances, however, you will be concerned with fasteners that have been constructed from cotton fabric and metal parts.

A closely woven cotton fabric is commonly used for the tape of a slide fastener; match the color of this tape to the main fabric color when installing a slide fastener.

On certain items of survival equipment using slide fasteners, it is mandatory that the slider remain stationary where it is positioned on the chain. An accidental opening in flight of an equipment container or item of flight clothing could cause a lot of trouble for the aircrewman.

Unintentional opening of a slide fastener that requires positive security is prevented by using a locking style L slider.

Illustrated in figure 10-20 are two common types of locking style L sliders: the pin type and the cam type. The pin type is designed to lock when the pull tab is pressed flat onto the chain, thereby inserting its pin between two teeth on one side of the chain.

The cam type is also designed to lock when the pull tab is pressed flat onto the chain, thereby causing friction between the chain and the cam. This action prevents any movement of the slider.

Slide fasteners installed where the movement of the slider is not critical may be equipped with

a style S, standard nonlocking slider. The style S slider is normally used on slide fasteners where accidental openings do not create a problem.

The length of a slide fastener is determined by the amount of closure required. When ordering slide fasteners from class 5325 of the Federal Stock Catalog, you need to refer to the dimension column, which lists both the length of the chain and the width of the tape. The size of a slide fastener is referred to as its service weight.

Activities should specify the brand of chain for which stops and sliders are required (Talon, Crown, or any other make).

Slide fasteners in stock are supplied in the nearest length ordered. When received, you can cut the chain to the desired length; stops can be salvaged and reused on the cut chain.

SEAMS AND KNOTS

A variety of seams and knots are presented in the following text.

HAND-SEWN SEAMS

This is the age of great technological advancements and man has come to rely heavily on the conveniences that technology provides. As you know, almost everything you do involves the use of a machine. From the housewife with her automatic dishwasher and the computer that pays you regularly twice each month to the sewing machine you use to repair articles made from fabric, technology is involved. Very few people in our society have the opportunity to use hand skills; therefore, they search for hobbies, such as model aircraft building, carpentry, and leather crafts to satisfy this desire.

You are fortunate because your job involves using both hand and machine skills. Very few people get the opportunity to work with raw and finished materials and have creating, fabricating, and repairing as part of their job. In your particular situation, not only do you use your hands for tying knots and packing life rafts, but you also use your hands to take the place of a sewing machine. By now you have seen that sewing is perhaps the most useful skill the fabrication and parachute specialist should develop. Few fabric maintenance jobs are performed without some kind of sewing. Although, from your experience, you know that most sewing is done with a machine; you also know there are occasions when machine sewing

is impractical or impossible because the design of the article may be such that using a machine would not meet the seam specification. Not only may some jobs be better done with hand sewing than with a machine, but also hand sewing is specified by technical order for certain jobs.

Some of the hand stitches you will use are basting stitch, running stitch, hidden stitch, overthrow stitch, and baseball stitch. You should use the one that best suits the particular job. To use these stitches properly, you should first become acquainted with the applicable definitions and general procedures.

A stitch is a unit of thread formation. A seam consists of a series of stitches (hand- or machine-sewn) joining two or more pieces of material. All seams should possess strength, elasticity, durability, and a good appearance. The strength of a seam depends upon the type of stitch used, type of thread used, number of stitches per inch, tightness of seam, construction of seam, and size and type of needle used. The appearance of a seam depends on how the seam is made. Even though you desire a good appearance, your first considerations should be elasticity, durability, and strength.

The elasticity desired in a seam is determined by the material being sewn. If the material possesses an elastic quality, the seam should also possess this same quality. If the seam does not possess the same elastic quality as the material, the stitches may break when stress is applied. A seam should be as durable as the material it joins. Tightly woven fabrics are more durable and have a smoother finish; therefore, they tend to slide on one another. To prevent this sliding, set the stitches tight and deep enough into the material to reduce wear caused by their rubbing on other surfaces.

When hand sewing cloth, turn under one-half inch of the material as reinforcement and insert the needle through both plies. When hand sewing thick materials, such as leather and felt, do not turn the edges under.

To hand sew any seam, you must know how to prepare for the job. Select the proper needle and thread. Choose a thread that matches the thread of the material as nearly as possible. Use the smallest size needle that allows the thread to pass easily through the eye of the needle. To thread the needle, pass one end of the thread through the eye and continue to pull it through until the ends meet. The resulting double thread should be no longer than an arm's length. Tie a binder's knot at the end of the doubled thread.

For sewing seams that require only one thread, pull only about 6 inches of thread through the eye, and then tie an overhand knot in the other end of the thread. Again, use no more than an arm's length of thread.

The overhand knot is the simplest knot made. It is important because it forms a part of the many other knots. To practice making this knot, get a short piece of cord and make a loop in it. Then pass the end through the loop and pull the loop tight. If two pieces of thread side by side are formed in a loop, the resulting knot is called a binder's knot. This knot is identical to the overhand knot except that two threads are used.

Most permanent hand-sewn seams in fabrics should be locked with two half hitches at intervals of 6 inches. These half hitches prevent any break in the seam from going past an interval. Lock all seams at the end with two half hitches, a square knot, or a surgeon's knot. A half hitch is simply an overhand knot whose loop passes around another item, such as a thread or an edge of material. To tie the square knot, tie a simple overhand knot. You then tie another overhand knot in the opposite direction, locking the first knot. The surgeon's knot is a modified form of the square knot. It is the same as the square knot with the exception of the first overhand knot, which is a double turn. This double turn keeps the cord from slipping while the last overhand knot is made.

Yellow beeswax is applied to hand sewing thread to prevent fraying and untwisting. Use only pure beeswax, since the impurities in other waxes may cause oil or grease spots, which deteriorate the thread. Beeswax preserves cotton thread; be sure to use it.

Other wax used in the survival equipment shop is made up of one part beeswax and one part paraffin. It is blended in a wax melting pot. If you are required to perform the task of waxing an entire spool of thread, place the wax pot on a wide, level surface. Place the electric cord of the wax pot so that you, or other personnel in your section, will not walk into it. Gently lower the thread into the hot, molten wax; don't let the thread rest on the bottom of the pot. How long you keep the thread in the wax pot is determined by the size and type of thread you are using. Follow these directions carefully to prevent the thread from burning or weakening because of overcooking.

When sewing, hold the needle between your thumb, index, and middle fingers. Push it forward

with the thimble on your fourth finger. Keep your fourth finger about two-thirds bent. Three fingers are needed to guide the needle accurately and swiftly from right to left. Hold the material in such a manner that you do not tire easily; crossing your legs and resting the material on them is helpful. Never point the needle outward at arm's length, because you may injure a passerby.

Purposes and Characteristics of the Basting Stitch

The basting stitch is used only for holding plies of material together temporarily, before machine sewing. This stitch is particularly helpful when you install a patch to a flight suit or a cover. Basting stitches are removed after making the machine seam.

Two types of needles can be used for basting-either the straight or the creed. Use the curved needle for hard-to-get-at areas, such as basting a patch on a cover; otherwise, the job can be done with a straight needle. Make the basting stitch as follows. Thread the needle with a sufficient length of 16-4 thread, single or waxed. Tie an overhand knot in the end of the single thread. Turn under the material edge one-half inch, unless specified otherwise in the technical order. Make each stitch one-fourth inch in length and one-eighth inch from the folded edge of the material. At the end of the row of basting stitches, lock the last stitch with two half hitches. Cut the thread one-fourth inch from the knot. Figure 10-25 illustrates the formation of the basting stitch.

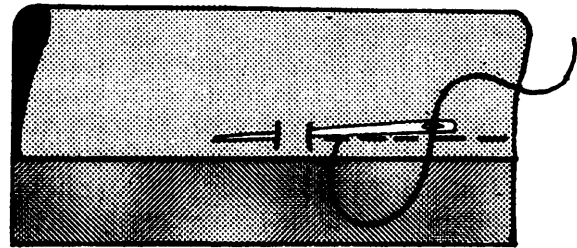
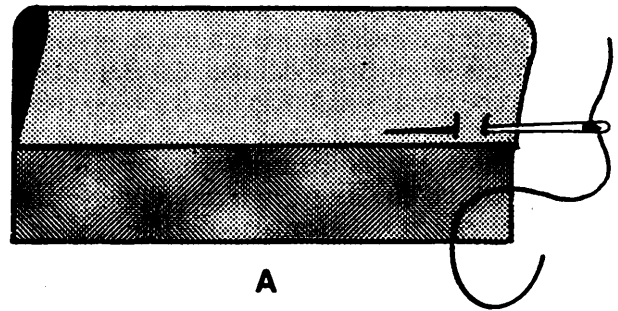

Figure 10-25.-Basting stitch.

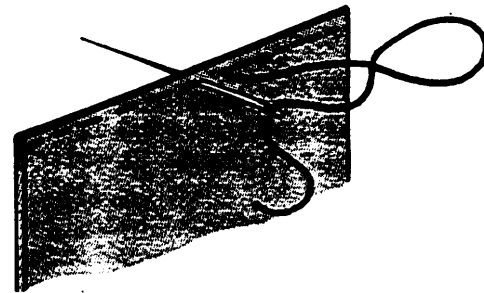

Figure 10-26.-Running stitch.

Hand Sewing the Running Stitch

You can use a running stitch as a substitute for a machine-sewn seam. It is designed to be a permanent stitch, when a sewing machine is not available. Use a straight needle threaded with single- or doubled-waxed cord or thread. Tie a knot at the end of the cord. The material should be turned under one-half inch. Insert the needle inside the one-half inch fold of one ply and push it through the three remaining plies so the starting knot will be hidden. Continue sewing the pieces together by using the basting stitch. When you come to the end of the row, turn the material around and go back in the opposite direction, filling in the empty spaces as you sew, as shown in figure 10-26. These two rows together become the running stitch. Use four stitches per inch (each stitch one-fourth inch long) and one-eighth inch

from the folded edge. Lock the seam every 6 inches.

Keep enough tension on the thread to form firm, well-set stitches. When you make the last stitch, insert the needle through two piles and bring it out in the center of the plies. Make two half hitches around the stitch extending from the second layer to the third layer of material.

Hand-sewn Overthrow Stitch

You use the overthrow stitch to attach metal parts, such as cones and eyelet. For this type of attachment, a sewing machine is not practical. The overthrow stitch is also used for harness tackings. A curved needle is used when the stitch can only be sewn from one side of the fabric. Fold the

material under one-half inch for reinforcement. Insert the needle in such a manner that the knot will be between the two pieces of material. Form the overthrow stitch by inserting the needle one-eighth inch from the folded edge and at right

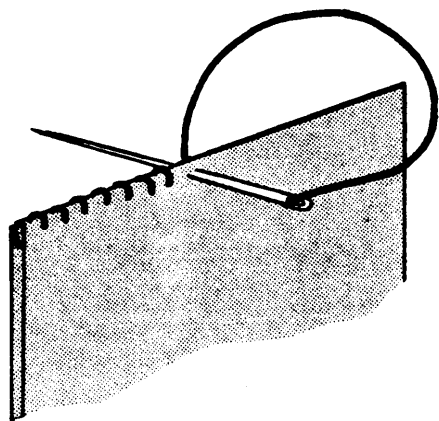

Figure 10-27.—Overthrow stitch.

angles to the material, as shown in figure 10-27. Make each stitch by inserting the needle from the same side as the previous stitch. For best results, make six stitches per inch. At the end of the row, tie off the thread with two half hitches.

Sewing the Baseball Stitch

The baseball stitch is a useful, permanent stitch, because it is very flexible and very elastic. It pulls the edges of material (cloth or leather) evenly together to form a flat surface, and it is used for repair or closing an opening. The thread lies on both the top and bottom edges of the material. Like lacing, it can be pulled as tightly as desired. Usually a curved needle is used to sew the baseball stitch.

Thread the needle with the required type of cord, waxed and tied with a knot at the end. If it is fabric to be sewn, rather than leather, turn the edges under one-half inch. Insert the needle through the fold of one ply of material to hide the knot, as shown in figure 10-28. Insert the

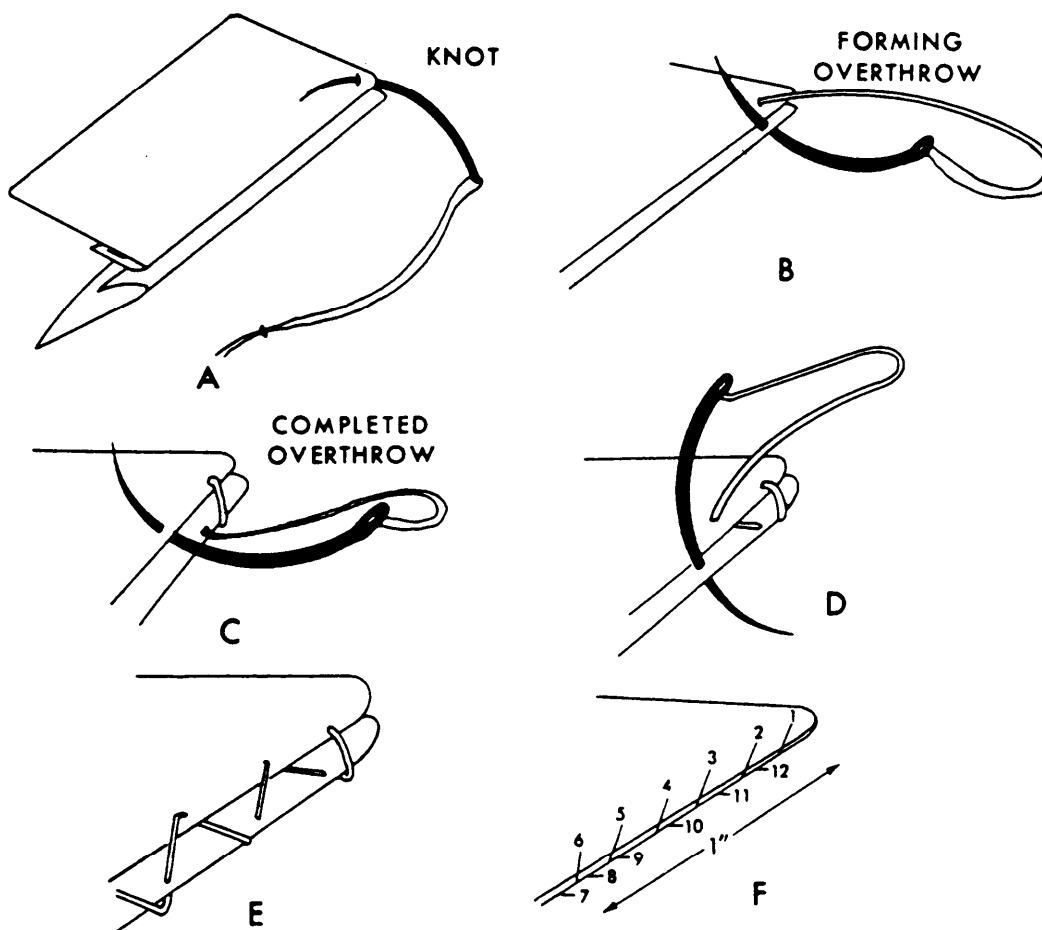
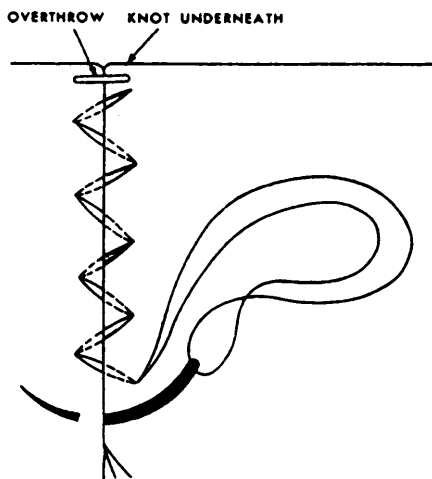

Figure 10-28.—Baseball stitch.

239.379



239.256A

Figure 10-29.—Baseball stitch (top view).

needle from the outside of the lower ply and bring it out the center of the plies, forming a straight overthrow stitch at the beginning of the seam, as shown in view B of figure 10-28. Start the baseball stitch by inserting the needle in the center of the plies toward the outside of the opposite piece of material, as shown in view C of figure 10-28. Proceed with the baseball stitch along the folded edges of the fabric (or the edges of the leather), as shown in figure 10-29. Insert the needle from the inside of the folded edges, only one-sixth inch from the folded edge, as shown in views D, E, and F of figure 10-28. Keep enough tension on the thread to remove all loops and slack thread. Do not apply too much tension because this tends to pucker or draw the seam out of line. Every time you sew 6 inches of the baseball stitch, make a lock knot, as shown in figure 10-30. After the last two stitches of the baseball stitch, finish with a straight overthrow stitch and two half hitches.

Use of the Hand-sewn Hidden Stitch and the Needle Used

The hidden stitch is usually used to make repairs on upholstery and on clothing where good appearance is important. To make this stitch, select a 2 1/2-inch curved needle and a length of suitable thread. Thread the needle to sew with a single thread and tie a knot in the long end. Fold under one-half inch of material and place it on the other piece of material, as shown in figure 10-31. Start the stitch by pushing the needle through the back of the fold, about one-eighth

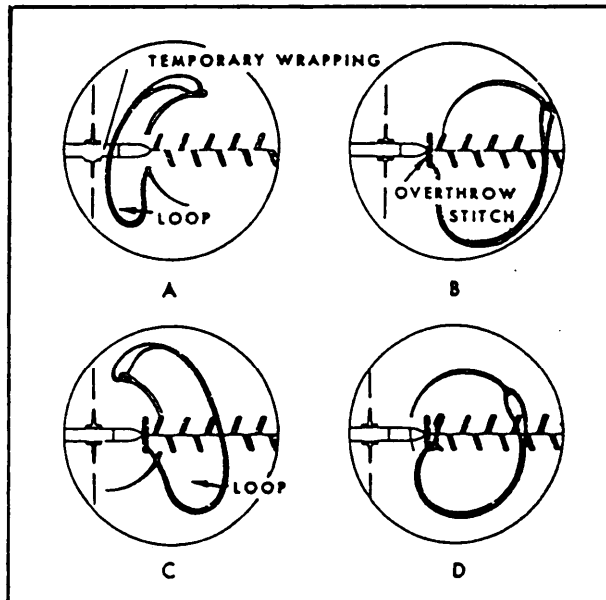

239.256B

Figure 10-30.—Forming a lock knot for the baseball stitch.

inch from the end. Pull the needle through the bottom material at a point directly below where the needle came out of the fold. Guide the needle so that the point comes out again about one-fourth inch along the line of the seam. The point should come out directly below the creased edge, as shown in view A of figure 10-31. Pull the needle and thread out to draw the stitch tight. Push the needle into the front edge of the fold directly above the point where the needle came out of the bottom material. Guide the needle point along the inside of the fold so that it again comes out the creased edge about one-fourth inch from where it entered, as shown in view B of figure 10-31. Pull the stitch tight and repeat the previous steps until the end is reached. Finish the seam off by coming back one stitch (through the opposite material) so that the needle reappears alongside the exposed thread of the next-to-the-last stitch. Tie two half hitches around the exposed thread.

MACHINE-SEWN SEAMS

Chances are you have been accomplishing sewing projects since you arrived at your new assignment. Then again, you may have done no sewing at all. The amount of sewing done in your shop depends upon the mission of your base. If your unit does much fabrication, then you probably will do quite a lot of machine sewing.

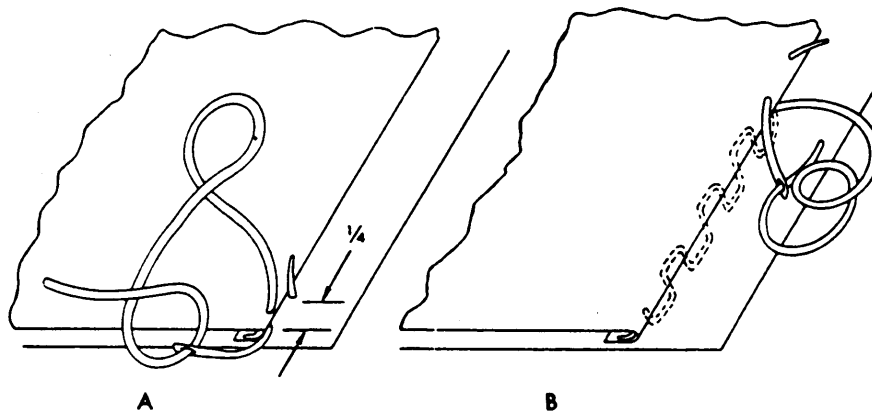

Figure 10-31.—Hidden stitch.

239.380

In this section, we discuss techniques concerning machine-sewn seams. While there is generally no option in choosing a hand-sewn seam, there are many options in choosing a machine seam.

Advantages and Characteristics of a Machine-Sewn Seam

Machine seams or stitchings have the following advantages over hand-sewn seams: (1) speed, (2) appearance, and (3) uniformity of tension. Their desirable characteristics are as follows:

STRENGTH. Strength of a seam of stitching depends on the type of thread, stitch type, number of stitches per inch, the construction and tightness of the seam, and the size and type of needle point used. The strength of the seam should equal that of the material it joins. Use only the material specified for the assembly in the applicable technical order.

ELASTICITY AND FLEXIBILITY. Elasticity and flexibility depend on the stretching qualities of the material used, the quality and tension of the thread, the length of the stitch, and type of seam or stitch used.

DURABILITY. Durability is determined by the wearing qualities of the material, the quality of the thread used, and proper tension to set stitches well into the material to reduce abrasions. Relationship between the elasticity of the seam and the elasticity of the material is very important in determining durability.

SECURITY. The security of a seam or stitching depends chiefly on the stitch type and its ability to resist unraveling. The stitch must be well set in the material to prevent snagging, which can cause thread breakage and unravel some types of stitches. Seam “run offs” weaken a seam. All seam ends should be backstitched or anchored (backstitched and overstitched) to prevent the seams from unraveling, as illustrated in figure 10-32.

APPEARANCE. The appearance of a seam is controlled by its construction and neatness of workmanship; however, appearance is of less importance than any of the four factors explained previously—strength, elasticity, durability, and security. Size and type of thread and length of stitch may also affect appearance.

Meanings and Symbols of Machine-Sewn Basic Stitches

Meanings and symbols of basic machine-sewn stitches are discussed in the following paragraphs.

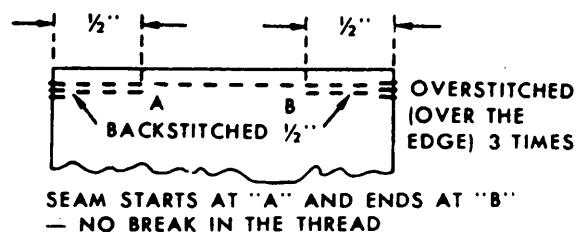

Figure 10-32.—Properly anchored machine seam.

STITCH. A stitch is one unit of thread formation resulting from passing a thread through material at uniformly spaced intervals. The class of stitch is indicated by a specification number; for example, 301, which specifies a United States Standard Lockstitch (one lock knot for each stitch). The class 31 and 111 sewing machines sew a United States Standard Lockstitch 301.

SEAM. A seam is a joint consisting of a sequence of stitches uniting two or more pieces of material.

STITCHING. A stitching consists of a sequence of stitches for finishing an edge, for ornamental purposes, or both in preparing parts for assembling.

The seam or stitch formation is indicated by a symbol consisting of three parts:

NOTE: The three parts follow the three-digit number showing the type stitch the machine makes.

1. The first part denotes the class and consists of two uppercase letters; for example, SS.
2. The second part denotes the type or the class of the seam or stitch formation and consists of one or more lowercase letters; for example, a.
3. The third part denotes the number of rows of stitches used and consists of one or more Arabic numerals preceded by a dash; for example, -1.

The complete seam specification for the examples given becomes 301-SSa-1. (Remember that the "301" is the machine class of stitch.)

There are places where one seam will be better than others. Experience has shown certain seams are best to serve a certain purpose. These seams have been standardized so that people who do sewing can turn out the same type of work. Standardization makes it possible to make drawings and blueprints that can specify a desired seam. This way, no matter who does the job, the finished article turns out to be as strong and durable as the designer wanted it.

Uses of Varying Classes of Machine-sewn Seams and Stitchings

The uses of varying classes of machine-sewn seams and stitchings are covered in the following material.

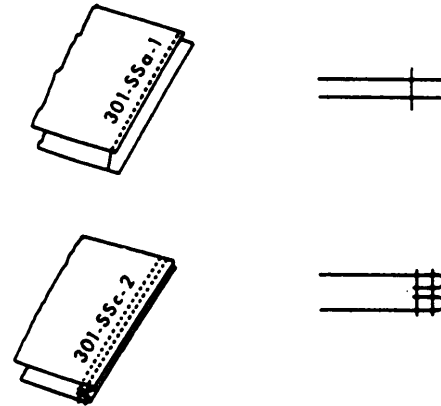

Figure 10-33.—Superimposed seam.

CLASSES OF SEAMS.— The three classes of seams are SS (superimposed seams), LS (lapped seams), and BS (bound seams).

Class SS, Superimposed Seams.— These seams are formed by placing one ply of material above another with the edges together and the seam along one side. Superimposed seams are usually made with two plies of material, although more than two plies can be used for special projects. The edges may be folded under, but they are never overlapped when the stitching is made. Types of superimposed seams are SSa-1 and SSc-2, as shown in figure 10-33.

1. The SSa-1 seam is the simplest method of joining two or more pieces of material. It is also used as the first step in the formation of other seams, such as the LSak-2 seam.

2. The SSc-2 seam is used for making many different types of covers. It is also used in making channels for sash cord when making handles on carrying bags and cases.

Class LS, Lapped Seams.— You form the class LS seam by overlapping the material a sufficient distance and stitching with one or more rows of sewing, as shown in the cross-sectional views in figure 10-34. Types of lapped seams are LSc-2, LSc-4, LSd-1, and LSak-2.

1. The LSc-2 seam is used for the sectional seams and the LSc-4 for the channel seams of parachute canopy. The interlocking of the folds makes the LSc seams the strongest of the seam formations.

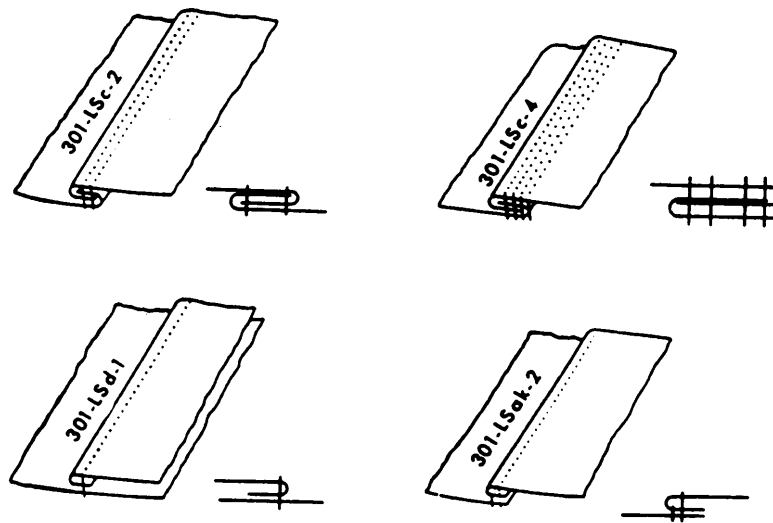

Figure 10-34.—Lapped seam.

2. The LSd-1 seam, as shown in figure 10-34, is used in sewing pockets or patches. Also, use the seam to patch small holes.

3. The LSak-2 seam, as shown in figure 10-34, is used for finishing seams of covers for shop equipment.

Class BS, Bound Seams.— BSA-2 seams are made by folding binding strips or tapes over the edges of the material to reinforce and finish the edges. Use the BSA-2 seam, as shown in figure 10-35, to bind the edges of tool aprons, reinforcement panels etc. Most soundproofing is bound with 3/4-inch tape using the BSA-2 seam.

CLASS OF STITCHING.— You form class EF (edge finishing) stitching by using the edge of a single ply of material to make the hem. The EFb-4 stitching, as shown in figure 10-36, is made by folding the edge back twice, thus turning the cut edge inside the second fold to prevent fraying and to reinforce the hem. The hem may also include a piece of reinforcing tape, plain or tubular webbing for adding strength. All seams

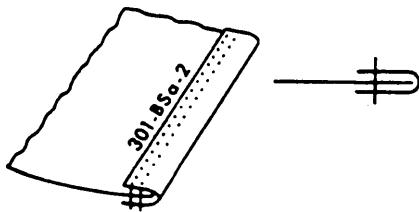

Figure 10-35.—Bound seam.

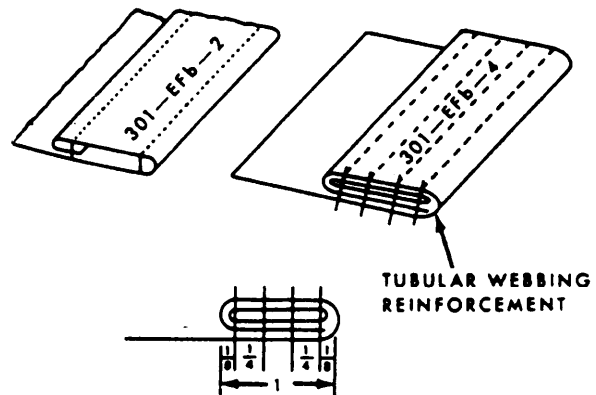

Figure 10-36.—Edge finishing stitching.

and stitches pictured are used in the survival equipment shop for modification and repair work on the parachute canopy, pack, seat, and back pads, or for making covers and bags for aircraft, shop equipment, and tools.

Appropriate Spacing of Machine-sewn Seams

The following rules will help you to space correctly more than one line of stitching and to place a seam the correct distance from the edge:

1. Sew regular binding tape one-sixteenth of an inch from the selvage edge of the tape.
2. Sew heavier tapes from one-sixteenth to one-eighth inch from the edge. Sew the raw ends of the tapes one-fourth inch from the raw edge.

3. Sew horsehide and thin leathers one-eighth inch from the edge in patching, trimming, etc.

4. Sew the raw edges of 8 to 15 ounce duck one-half inch from the edge.

5. Fold the material no less than one-half inch for reinforcement.

6. Sew the folded edges of 8 to 15 ounce duck one-eighth inch from the folded edge.

7. Make the second and succeeding rows of stitches one-fourth inch apart. In heavier material, it is sometimes desirable to separate the rows as much as three-eighths of an inch.

8. Heavy duck, heavy fabric, or the heavier leathers may be sewn approximately one-fourth inch from folded edges for best results, while the raw edges of such heavy fabrics need at least one-half inch to three-fourths inch seams for security.

9. Sew light nylon or aircraft fabric one-sixteenth inch from the folded edge. Raw edges of these light materials are seldom sewn together, except as the first step of another seam.

10. When you are sewing a row of stitches and the thread breaks, start sewing again one-half inch behind the break, and sew on top of the existing stitches. This is called backstitching.

The stitches that form the various classes of seams should be tight, even, and well-set into the material. An understanding of how the machine functions to form the stitch and feed the material provides the basis for you to sew high-quality seams consistently.

KNOTS

A boy scout's first achievement is to learn to tie knots. Knots are necessary to many activities—camping, boating, mountain climbing, and parachute rigging. Different knots serve different purposes. For instance, a hangman would be out of a job if he forgot how to make a slip knot. A doctor would have trouble sewing his patient up after an appendectomy if he didn't make a proper surgeon's knot. Also, you could never pack a parachute correctly without a working knowledge of several different types of knots.

Some specialists have a tendency not to be as concerned about knots as they are about other items involved in servicing parachutes. Think of knots as the treads (and the depth of the treads) on your automobile tires. Sure, the tire can perform without treads. But, if the tires are going to grip the road surface and stop the automobile

in the shortest time and distance possible, they require good tread depth. Tire treads are designed to meet many performance requirements. The same principles apply to knots used in parachute rigging.

Make sure that all knots and tackings are changed as often as possible. Their "tread" deteriorates and becomes loose. Parachutes are designed to perform under the most unpredictable situations, at speeds and configurations too great to imagine. One poorly made knot and tacking could cause burned suspension lines, excessive opening shock, or oscillation—all of which could result in the failure of the parachute. Remember, no matter how small the task, treat each area of the parachute with the greatest care and concern.

The type of knot used in assembling component parts of parachutes depends on the purpose for which the knot is intended, the strength required, and the kind of thread, rope, or cord that is to be used. Remember, knots, hitches, and turns decrease the tensile strength of rope, cord, or thread, as shown in figure 10-37. Some knots are tied for the purpose of breaking during parachute deployment, and other knots are tied so as not to break. This is why it is so important that only the specified knots be used for a particular job. The following text discusses the knots you will have to tie as you go about your job of servicing parachute assemblies.

Overhand knot

The overhand knot is the simplest knot made, as shown in figure 10-38. It is very important,

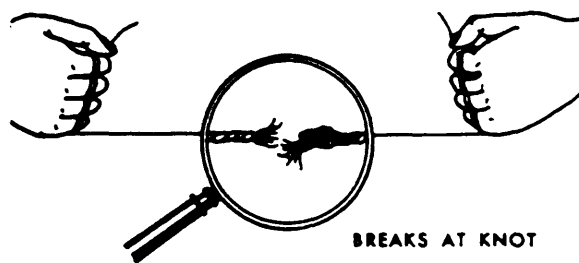

Figure 10-37.—Tensile strength decreased by knot.



Figure 10-38.—Overhand knot.

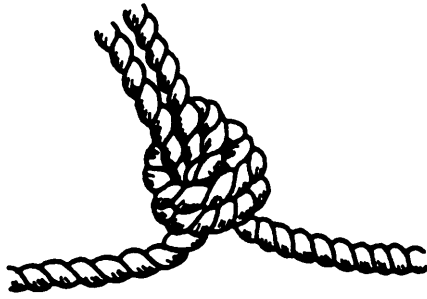

Figure 10-39.—Binder's knot.

however, since it forms a part of many other knots. You use the overhand knot at the end of a single thread when you are hand sewing.

Binder's Knot

A binder's knot is the simplest method of joining two cords or threads together, as shown in figure 10-39. Use it at the end of a double cord when hand sewing to prevent the cord from pulling through the material as you sew.

Square Knot

The square knot is the most common knot for joining two ropes or cords, as shown in figure 10-40. It can be easily and quickly tied and untied, and it is secure and reliable except when made with ropes and cords of two different sizes.

Surgeon's Knot

The surgeon's knot is a modified form of the square knot (figs. 10-41 and 10-42). In fact, it

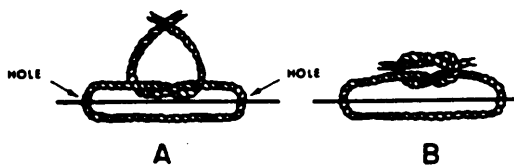

Figure 10-40.—Square knot.

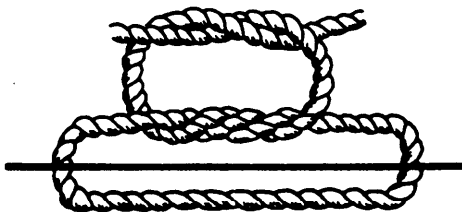

Figure 10-41.—Surgeon's knot.

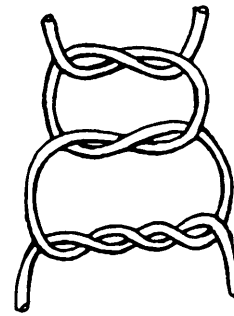

Figure 10-42.—Surgeon's and lock knot.

is the same as the square knot, with the exception of the first overhand knot, which is a double turn. This double turn keeps the cord from slipping while the last overhand knot is tied.

Bowline

The bowline is used to connect the reserve parachute pilot chute bridle line to the canopy vent lines (fig. 10-43).

Half Hitch

The half hitch, shown in figure 10-44, is used to form the tie for the safety ties on ripcord pins



Figure 10-43.—Bowline. 3.218(3D)

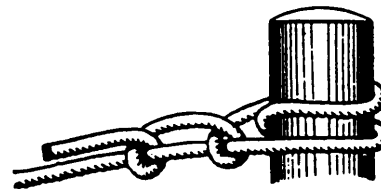

Figure 10-44.—Round knot and two half hitches. 3.221

on the various types of personnel, cargo, and deceleration parachutes. Normally, three half hitches in a series are used for the safety tie.

Clove Hitch

The clove hitch, shown in figure 10-45, is used to secure the suspension lines to the connector links on many parachute assemblies.

You know how to tie the most common knots used in parachute rigging. For even greater security, these knots can be modified to form several other knots. The lock knot is an overhand knot tied adjacent to many other knots. For

example, to prevent the square and lock knots or the surgeon's and lock knot from slipping, you tie overhand knots at each end of the thread or cord. Also, the overhand knot can be tied in a series. The same applies to the surgeon's knot. The binder's knot leaves a loose end to form a slip knot, which is used to temporarily tie an excess amount of cord. The AS28A deployment bag uses this type of knot. Also, when you secure the automatic ripcord release's arming knot guide on the automatic seat style parachute, you use a slip knot tied off with a lock knot. The specific knots you use are determined by the engineers who design, test, and establish criteria for the operation and function of parachute assemblies.



Figure 10-45.—Tying a clove hitch.

3.220

CHAPTER 11

OXYGEN COMPONENTS TEST STANDS

Learning Objective: Upon completion of this chapter, you will be able to identify, maintain, and perform periodic inspections on oxygen components test stands.

Aircrew Survival Equipmentmen are responsible for shop testing aircraft oxygen system components, including regulators, emergency oxygen systems, and other items. The AME is responsible for checking system components in the aircraft; however, in case of a suspected malfunction and for periodic maintenance testing, the component is removed from the aircraft and brought to the oxygen shop where it is tested by the PR. This testing is accomplished with the use of various types of test equipment, some of which are discussed in this chapter.

OXYGEN

No one can live without sufficient quantities of food, water, and oxygen. Of the three, oxygen is by far the most urgently needed. If necessary, a well-nourished individual can go without food for many days or weeks, living on what is stored in the body. The need for water is more immediate, but still the need does not become critical for several days. The amount of oxygen in the body is limited at best to a few minutes supply. When that supply is exhausted, death is prompt and inevitable.

Oxygen starvation affects a pilot or aircrewman in much the same way that it affects an aircraft engine—neither can function without it. The engine requires oxygen for burning the fuel that keeps it going. An engine designed for low-altitude operation loses power and performs poorly at high altitudes. High-altitude operation demands a means of supplying air at higher pressure to give the engine enough oxygen for the combustion of its fuel. The supercharger or compressor performs this function.

The combustion of fuel in the human body is the source of energy for everything the aviator

is required to do with his muscles, with his eyes, and with his brain. As the aircraft climbs, the amount of oxygen per unit of volume of air decreases; therefore, the aviator's oxygen intake is reduced. Unless he/she breathes additional oxygen, the eyes, the brain, and the muscles begin to fail. The body is designed for low-altitude operation and will not give satisfactory performance unless it is supplied the full amount of oxygen that it requires. Like the engine, the body requires a means of having this oxygen supplied to it in greater amounts or under greater pressure. This need is satisfied by the use of supplemental oxygen supplied directly to the respiratory system through an oxygen mask, by pressurizing the aircraft to an atmospheric pressure equivalent to that of safebreathing altitudes, or both.

For purposes of illustration, an aviator's lungs may be compared to a bottle of air. If an open bottle is placed in an aircraft at sea level, air escapes from it continuously as the aircraft ascends. The air pressure at 18,000 feet is only half the amount as that at sea level; therefore, at 18,000 feet the bottle is subjected to only half the atmospheric pressure it was subjected to at sea level. For this reason, it will contain only half the oxygen molecules it had when on the ground.

In like fashion, an aviator's lungs contain less and less air as he/she ascends, and correspondingly less oxygen. Thus, the use of supplemental oxygen is an absolute necessity on high-altitude flights. Above 35,000 feet, normal activity is possible up to about 43,000 feet by use of positive pressure equipment. This equipment consists of a "supercharger" arrangement by which the oxygen is supplied to the mask under a pressure slightly higher than that of the surrounding atmosphere. Upon inhalation, the

oxygen is forced into the lungs by the system pressure. Upon exhalation, the oxygen flow is shut off automatically so that carbon dioxide can be expelled from the mask. Normal activity is possible to 50,000 feet with the use of a pressure breathing oxygen regulator. Above 50,000 feet, the only adequate provision for the safety of the aviator is pressurization of the entire body.

Up to about 35,000 feet, an aviator can keep a sufficient concentration of oxygen in his/her lungs to permit normal activity by use of demand oxygen equipment, which supplies oxygen upon demand (inhalation). The oxygen received by the body on each inhalation is diluted with decreasing amounts of air up to about 30,000 feet. Above this altitude up to about 35,000 feet, this equipment provides 100-percent oxygen. At about 35,000 feet, inhalation alone will not provide enough oxygen with this equipment.

EFFECTS OF HYPOXIA

A decrease in the amount of oxygen per unit volume of air results in an insufficient amount of oxygen entering the bloodstream. The body reacts to this condition rapidly. This deficit in oxygen is called HYPOXIA. A complete lack of oxygen, which causes death, is called ANOXIA. If the body is returned to its normal oxygen supply, one may recover from hypoxia, but cannot recover from anoxia.

Many persons are not aware of the enormous increase in the need for oxygen caused by an increase in physical activity. Strenuous calisthenics or a cross-country run results in deep and rapid breathing. Even so mild an exercise as getting up and walking around a room may double the air intake. In the case of the aviator, a leaking oxygen mask that may go completely unnoticed while the wearer is at rest may lead to collapse and unconsciousness when he/she attempts to move about from one station to another in the aircraft. A walkaround (portable) oxygen bottle sufficient for 24 minutes of quiet breathing may be emptied by 17 minutes of use when the user is moving about the aircraft.

People differ in their reactions to hunger, thirst, and other sensations. Even an individual's reactions vary from time to time under different circumstances. Illness, pain, fear, excessive heat or cold, and many other factors govern what the

response will be in each particular case. The same thing is true of individual reactions to oxygen starvation. The effects of a certain degree of hypoxia on a given person cannot be accurately predicted. For instance, a person may be relatively resistant on one day, but highly susceptible the next.

It is difficult to detect hypoxia, because its victim is seldom able to judge how seriously he/she is affected, or often that he/she is affected at all. The unpleasant sensations experienced in suffocation are absent in the case of hypoxia. Blurring of vision, slight shortness of breath, a vague weak feeling, and a little dizziness are the only warnings. Even these may be absent or so slight as to be unnoticeable.

While still conscious, the aviator may lose all sense of time and spend his last moments of consciousness in some apparently meaningless activity. In such a condition, the aviator is a menace to the crew as well as to himself. Since the aviator understands that it is the reduced air pressure at higher altitudes that determines the effect upon the body, he/she depends upon the altimeter rather than sensations or judgment to tell when oxygen is needed.

CHARACTERISTICS OF OXYGEN

Oxygen, in its natural state, is a colorless, odorless, and tasteless gas. Oxygen is considered to be the most important to life of all the elements. It forms about 21 percent of the atmosphere by volume and 23 percent by weight.

Of all the elements in the universe, oxygen is the most plentiful. It makes up nearly one-half of the earth's crust and approximately one-fifth of the air we breathe.

Oxygen combines with most of the other elements. The combining of an element with oxygen is called oxidation. Combustion is simply rapid oxidation. In almost all oxidations, heat is given off. In combustion, the heat is given off so rapidly it does not have time to be carried away; the temperature rises extremely high, and a flame appears.

Some examples of slow oxidation are the rusting of iron, drying of paints, and the changing of alcohol into vinegar. Even fuels in storage are

slowly oxidized, the heat usually being carried away fast enough; however, when the heat cannot easily escape, the temperature may rise dangerously and a fire will break out. This is called spontaneous combustion.

Oxygen does not burn, but does support combustion. Nitrogen neither burns nor supports combustion. Therefore, combustible materials burn more readily and more vigorously in oxygen than in air, since air is composed of about 78 percent nitrogen by volume and only about 21 percent oxygen.

In addition to existing as a gas, oxygen can exist as a liquid and as a solid. Liquid oxygen is pale blue in color. It flows like water, and weighs 9.54 pounds per gallon.

Liquid oxygen, commonly referred to as LOX, is normally obtained by a combined cooling and pressurization process. When the temperature of gaseous oxygen is lowered to -182°F under about 750 psi pressure, it will begin to form into a liquid. When the temperature is lowered to -297°F , it will remain a liquid under normal atmospheric pressure.

Once converted into a liquid, oxygen will remain in its liquid state as long as the temperature is maintained below -297°F . The liquid has an expansion ratio of 862 to 1, which means that one volume of liquid oxygen will expand 862 times when converted to a gas at atmospheric pressure. Thus, 1 liter of liquid oxygen produces 862 liters of gaseous oxygen.

Until a few years ago, all oxygen carried in naval aircraft was in the gaseous state. As flight durations increased, however, it was found that the weight and space problems involved with carrying increasing amounts of gaseous oxygen were becoming intolerable. LOX has proven the answer to these problems. In its liquid state, oxygen can be "packed" into containers small and light enough to be carried even in fighter-type aircraft without weight and space penalty.

In the aircraft, oxygen in the liquid state is carried in a container called a converter. This is a double-walled, vacuum-insulated container similar to the common Thermos bottle. The converter is equipped with the necessary valves and tubing for vaporizing the liquid and warming the gas to cockpit temperatures.

TYPES OF OXYGEN

Aviator's breathing oxygen (MIL-O-27210C) is supplied in two types (I and II). Type I is gaseous oxygen, and type II is LOX. Oxygen procured under the above specification is required to be 99.5 percent pure. The water vapor content must not be more than 0.02 milligram per liter when tested at 70°F and at sea level pressure. This is practically bone dry.

Technical oxygen, both gaseous and liquid, is procured under specification BB-0-925. The moisture content of technical oxygen is not as rigidly controlled as that of breathing oxygen; therefore, the technical grade should never be used in aircraft oxygen systems.

The extremely low moisture content required of breathing oxygen is not to avoid physical injury to the body, but to ensure proper operation of the oxygen system. Air containing a high percentage of moisture can be breathed indefinitely without any serious ill effects. However, the moisture affects the aircraft oxygen system in the small orifices and passages in the regulator. Freezing temperatures can clog the system with ice and prevent oxygen from reaching the user. Therefore, extreme precautions must be taken to safeguard against the hazards of water vapor in oxygen systems.

OXYGEN COMPONENT TEST STAND 1172AS100

Regulator test stands are designed for testing oxygen regulators for flow capacities, oxygen concentrations, pressure characteristics, and various leakage tests at different simulated altitudes. There are several models of test stands capable of testing the oxygen regulators, converters, etc. We will cover only the ones that most oxygen shops throughout the Navy use. If you happen to work in an oxygen shop that is using outdated equipment, ask the petty officer in charge of the work center to show you the literature that covers that equipment. In this rate training manual, we will discuss only the 1172AS100 test stand used for testing oxygen regulators.

The Oxygen System Components Test Stand, Model 1172AS100, tests and evaluates miniature oxygen breathing regulators as well as panel and

console mounted oxygen breathing regulators. (See figure 11-1.)

Oxygen system components test stands are supplied by more than one manufacturer. The operation, maintenance, and parts are, with a few minor exceptions, identical. Where there are differences in applications, or where operational procedures differ, they will be redescrbed in the individual regulator chapters of NAVAIR Publication 13-1-6.4. Therefore, before you attempt to test any oxygen component, you should refer to that manual.

The oxygen system components test stand consists of a nitrogen pressure source and a vacuum system. It includes the valving and instrumentation necessary to measure, test, and evaluate the performance and operating characteristics of oxygen system components at altitudes up to 150,000 feet.

Performance of the test stand is dependent upon the skill of the operator. You must be thoroughly familiar with the instruments, controls, and connections that comprise the systems that are incorporated within the test stand (fig. 11-1).

ON/OFF VALVES

There are two ON/OFF valves on the test stand. These valves are colored red and have two positions—ON and OFF. The first valve is called the inlet pressure ON/OFF valve (L). This valve permits a flow of regulated high-or low-pressure nitrogen to the input connection (18) located inside the altitude chamber. The second ON/OFF valve is called the Leakage ON/OFF valve (G). This valve permits a flow of regulated low-pressure nitrogen gas (N_2) through the selected in-system rotameter (7) or (8). You select either the low-range or the high-range rotameter by using the leakage selector valve (F). Valve (G), the leakage ON/OFF valve, also permits a supply of N_2 to go to the input connection (18) inside the chamber. The only time you will be using ON/OFF valve (G) is when you are adjusting the bleed on a miniature oxygen regulator (this is covered in the NAVAIR 13-1-6.4) and when you are measuring leakage on oxygen components.

SELECTOR VALVES

As you look at the Model 1172AS100 test stand, you may think that with all those different valves, gauges, rotameters, and connections that you could never operate it. However, by operating

only four selector valves, you can direct the flow of N_2 to perform the basic functions of the stand. These valves are M, O, D, and F, shown in figure 11-1.

The FLOW SELECTOR valve (M) has two positions—CONTROLLER and REGULATOR. When this valve is placed in the REGULATOR position, and you open the OUTPUT valve (C), the flow is routed directly from the item under test through the piezometer (26) and OUTPUT port (23) to the vacuum pump. When the selector valve is placed in the CONTROLLER position, the flow is routed through the suit simulator tank.

The REFERENCE PRESSURE SELECTOR valve (O) is a two-position valve. It references pressure to either the altitude chamber or the suit simulator tank from LOW RANGE ALTIMETER (13).

The PRESSURE SELECTOR valve (D) has two positions— H_2O (water) and Hg (mercury). In the Hg position, only mercury pressure can be read. In the H_2O position, either inches of water pressure (positive pressure) or inches of water suction (negative pressure) can be read.

The LEAKAGE SELECTOR valve (F) has two positions—HIGH and LOW. It routes regulated low pressure through the in-system rotameters. When the valve is placed in the LOW position, leakage is indicated on rotameter (7). The LEAKAGE SELECTOR valve (F) is always left in the HIGH position unless you are reading a leak or bleed below 200 cubic centimeters (CCM). This is done to prevent damage to the low-range rotameter in the event you develop a severe leak.

VOL-O-FLO ELEMENTS

To understand the function of some of the valves discussed in the following paragraphs, it is necessary to first understand the function of the Vol-O-Flo elements installed between certain control valves and their indicating manometers. There are three Vol-O-Flo elements installed on the test stand. The input Vol-O-Flo works in conjunction with INPUT valve (A) and INPUT FLOW manometer (2). The output Vol-O-Flo is used with OUTPUT valve (C) and OUTPUT FLOW manometer (1). The vent flow Vol-O-Flo is used with either the VENT PRESSURE valve (H) or the VENT AMBIENT valve (1) and the VENT FLOW manometer (3).

The Vol-O-Flo elements have two taps—one near the inlet end and one near the outlet end.

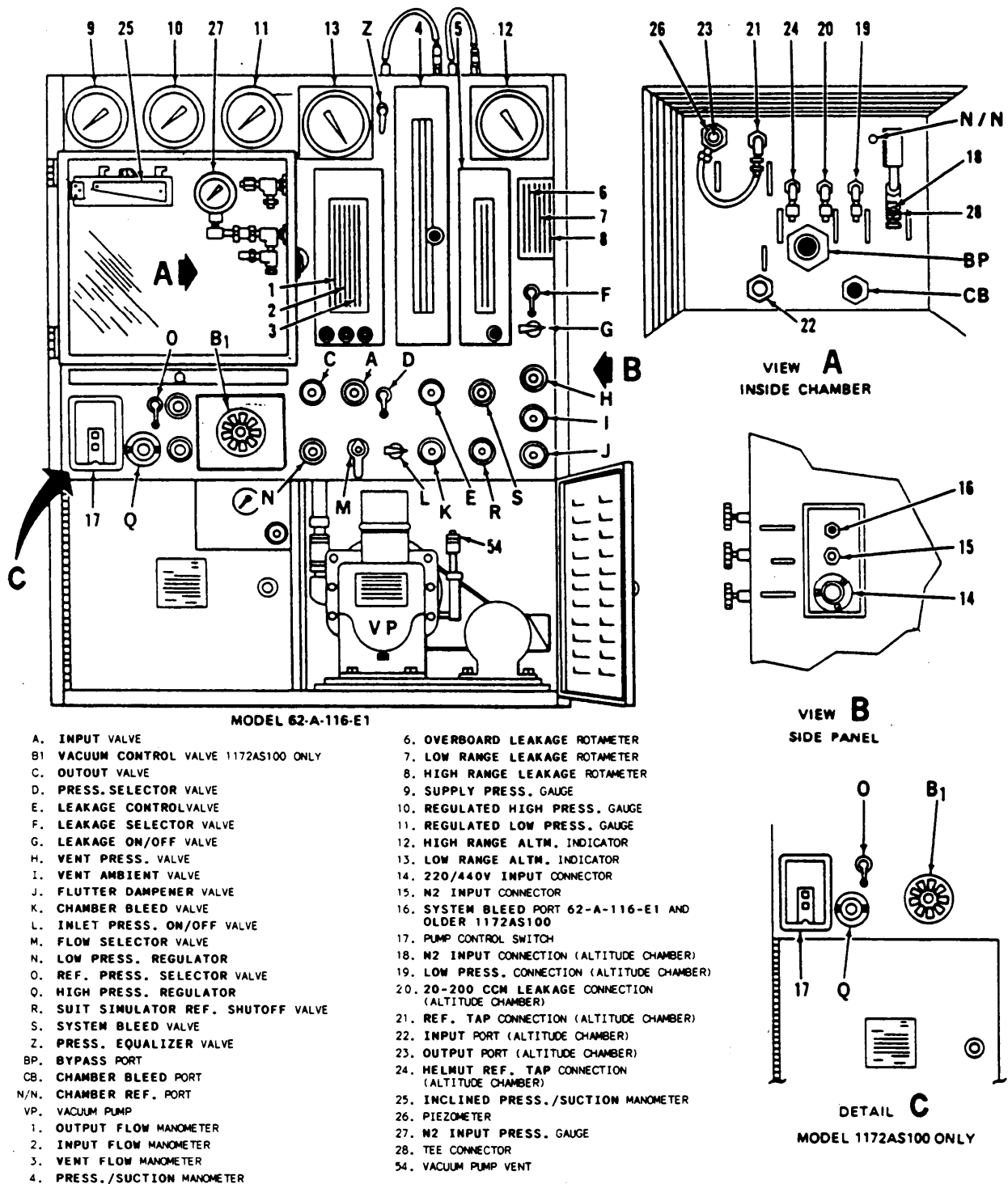

239.476

Figure 11-1.-Controls and indicators for Oxygen System Components Test Stand Model 117AS100.

(See figure 11-2.) Baffles inside the element create a flow restriction. As air or nitrogen enters the element, a pressure buildup is created at the inlet end; as it flows past the baffles, a pressure drop occurs at the outlet end. The inlet (pressure buildup) tap is connected to the bottom of the indicating manometer, and the outlet (pressure drop) tap is connected to the top of the manometer. As the control valve is opened, gas flows from the valve through the Vol-O-Flo, and the pressure drop thus created allows the fluid in the manometer to rise. The operator reads the amount of flow passing through the Vol-O-Flo on the indicating manometer.

CONTROL VALVES

A control valve regulates, or restricts, a specified flow. Two types of control valves, measuring and nonmeasuring, are used on the test stand. Measuring control valves have measuring devices (gauges or manometers) to visually measure the flow through the valve as it is opened. Nonmeasuring control valves have no indicating devices. There are six measuring and three nonmeasuring control valves on the test stand.

Measuring Control Valves

The measuring control valves (fig. 1 1-l) are as follows:

1. The INPUT valve (A) allows a measurable flow of air into the altitude chamber. It can only

be used during simulated altitude conditions. As the chamber altitude increases, pressure inside the chamber decreases, and the ambient air pressure outside the chamber is greater. When valve (A) is opened, air from outside the chamber flows through valve (A); through the input Vol-O-Flo element, indicating the amount of air flow on the INPUT FLOW manometer (2); and through the INPUT port (22) into the chamber.

2. The VACUUM CONTROL valve (B1) on Model 1172AS100 allows direct evacuation of the altitude chamber to the desired simulated altitude by decreasing pressure in this chamber.

3. The OUTPUT valve (C), when opened, draws a direct flow from the item under test through the piezometer (26), OUTPUT port (23), FLOW SELECTOR valve (M) and the output Vol-O-Flo element to the vacuum pump. As the flow passes through the output Vol-O-Flo, the pressure is displayed on the OUTPUT FLOW manometer (1).

4. The LEAKAGE CONTROL valve (E) controls the flow to the LOW-PRESSURE connection (19), which is located inside the chamber. As the name of the valve implies, it is used to perform various leak tests on oxygen components. When you use the LEAKAGE CONTROL valve (E) to perform leakage tests on components, a line with bayonet fittings must be installed between the LOW-PRESSURE connection (19) and the REFERENCE-TAP connection (21). This allows the flow passing

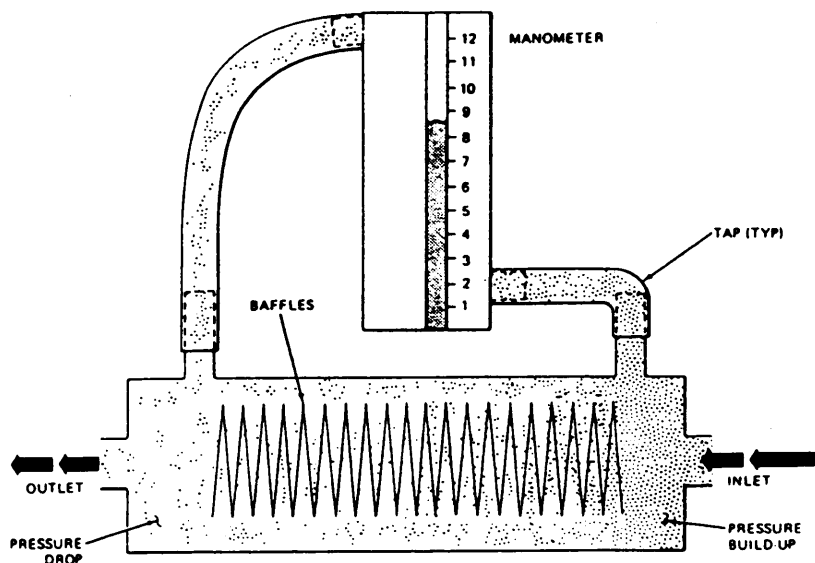

Figure 11-2.—Vol-O-Flo element.

239.477

through valve (E) to be indicated on PRESSURE/SUCTION manometer (4) or Hg manometer (5), whichever you have selected. Any leakage would be registered on rotameters (7) or (8).

5. The VENT PRESSURE valve (H) controls a vent flow of low pressure through the suit simulator tank to the item under test at sea level. When valve (H) is opened, nitrogen (N_2) flows through the vent flow Vol-O-Flo element, and is indicated on VENT FLOW manometer (3). The flow then passes to the suit simulator tank, through FLOW SELECTOR valve (M), OUTPUT connection (23) and piezometer (26) to the item under test. Valve (H) is primarily used for testing relief valves.

6. The VENT AMBIENT valve (I) serves the same purpose as VENT PRESSURE valve (H), except that valve (H) is used at sea level with supply pressure, while valve (I) is used at altitude and uses ambient air as the pressure source to conserve N_2 . Therefore, valve (I) can be considered an economizer valve, used only "at altitude."

Nonmeasuring Control Valves

The nonmeasuring valves (fig. 11-1) are opened only as much as necessary. Flow through these valves cannot be measured or gauged. The nonmeasuring valves are as follows:

1. The FLUTTER DAMPENER valve (J) allows an opening from the suit simulator tank to the line connecting FLOW SELECTOR valve (M) and OUTPUT valve (C). It acts as a dampener to prevent fluttering of specific regulator diaphragms during testing, and allows a flow to be drawn from a test item through the suit simulator tank when FLOW SELECTOR valve (M) is in the CONTROLLER position.

2. The CHAMBER BLEED valve (K) is used to bring the chamber to sea level from a simulated altitude.

3. The SYSTEM BLEED valve (S) is used to bleed N_2 pressure from systems of the test stand through SYSTEM BLEED port (16). On later configurations of Model 1172AS100, SYSTEM BLEED port (16) has been deleted. N_2 pressure is bled directly from a port incorporated in the SYSTEM BLEED valve (S).

SHUTOFF VALVES

There is only one shutoff valve on the 1172AS100 test stand (fig. 11-1). It is the SUIT

SIMULATOR REFERENCE SHUTOFF valve (R). It is used to prevent damage to other components. The SUIT SIMULATOR REFERENCE SHUTOFF valve shuts off the suit simulator tank from REFERENCE PRESSURE SELECTOR valve (O) and HELMET REFERENCE TAP (24). When you use a shutoff valve, you should fully open the valve, and then turn it back one-fourth turn.

CAUTION

IF SUIT SIMULATOR VALVE (R) IS LEFT OPEN WITH REFERENCE PRESSURE SELECTOR VALVE (O) IN THE SUIT SIMULATOR TANK POSITION, DAMAGE COULD OCCUR TO LOW RANGE ALTM (13) IF EXCESSIVE PRESSURE IS APPLIED TO IT WITH VENT PRESSURE VALVE (H).

REGULATORS

There are two regulators on the 1172AS100 test stand (fig. 11-1). They control the supply pressure to the specific system being used. The regulators are as follows:

1. The HIGH PRESSURE REGULATOR (Q), which is pneumatically operated. It supplies regulated high pressures from 250 pounds per square inch, gauge (psig) to the maximum capacity of the supply cylinder being used. Regulator (Q) has three positions—LOAD, NEUTRAL, and VENT. It is spring loaded in the NEUTRAL position. Pressure being loaded is indicated on REGULATED HIGH PRESSURE gauge (10).

2. The LOW PRESSURE REGULATOR (N), which is mechanically operated, supplies regulated low pressure to the item under test, the in-system rotameters, and the suit simulator tank. Regulator (N) has a range of 0 to 180 psig. The pressure being loaded is displayed on REGULATED LOW PRESSURE gauge (11), and is also displayed on N_2 INPUT gauge (27) when the INLET PRESSURE ON/OFF valve (L) is in the ON position.

GAUGES AND INDICATORS

Gauges and indicators incorporated in the test stand (fig. 11-1) indicate pressures or flows. Some indicate in pounds per square inch, gauge (psig), some in feet, inches of mercury (inches Hg),

millimeters of mercury (mm Hg), inches of water (inches H₂O), or cubic centimeters per minute (CCM). Their functions are self-explanatory.

1. The SUPPLY PRESSURE gauge (9) is a 0 to 3,000 psig gauge and indicates supply cylinder pressure.

2. The REGULATED HIGH PRESSURE gauge (10) is a 0 to 3,000 psig gauge and indicates regulated high pressure.

3. The REGULATED LOW PRESSURE gauge (11) is a 0 to 200 psig gauge and indicates regulated low pressure.

4. The INPUT PRESSURE gauge (27) is a 0 to 160 psig gauge and indicates regulated low pressure.

5. The LOW RANGE ALTM (13) measures chamber altitude pressure and, under some circumstances, suit simulator tank pressure. It measures pressures equivalent to altitudes between 10,000 and 40,000 feet.

6. The HIGH RANGE ALTM (12) measures chamber altitude pressure to indicate the altitude range equivalent to between 30,000 and 150,000 feet.

NOTE: Each altimeter incorporates an inner scale, which indicates altitude in mm Hg instead of in feet.

7. The PRESSURE/SUCTION manometer (4) has a range of -12.0 to +26.0 inches H₂O, and measures the amount of differential pressure between piezometer (26) and the altitude chamber, or between the piezometer and the suit simulator tank. It is used during component testing to measure safety pressure and pressure breathing pressures being delivered by the component and to measure suction flows being drawn through the component.

8. The Hg manometer (5) has a range of 0 to 12.0 inches Hg and measures, in inches Hg, the amount of differential pressure between piezometer (26) and the altitude chamber, or between the piezometer and the suit simulator tank. It is used to measure resistance in an item under test.

NOTE: The rotameters used on the test stand are of the variable area type, which means they get progressively larger toward the top, allowing more nitrogen to pass around the ball. The point at which the ball stabilizes is known as the point of dynamic balance. Readings are made across the center of the ball.

9. The OVERBOARD LEAKAGE rotameter (6) has a range of 20 to 200 CCM (1,000 CCM = 1 lpm) and is vented to ambient. It measures leakage, or bleed, from an item under test. This rotameter is calibrated at 14.7 psig at 70°F (ambient air).

10. The LOW RANGE LEAKAGE rotameter (7) has a range of 20 to 200 CCM, and is enclosed in the low-pressure system. It measures leakage, or bleed, from a component under test through LEAKAGE CONTROL valve (E), or LEAKAGE ON/OFF valve (G). This rotameter is calibrated with nitrogen at 70 psig at 70°F.

11. The HIGH RANGE LEAKAGE rotameter (8) has a range of 200 to 2000 CCM. Its function is the same as LOW RANGE LEAKAGE rotameter (7). This rotameter is calibrated at 70 psig at 70°F.

12. The OUTPUT FLOW manometer (1) has a range of 0 to 12.0 inches H₂O. It indicates the amount of output flow from the item under test.

13. The INPUT FLOW manometer (2) has a range of 0 to 12.0 inches H₂O. It indicates the amount of ambient air flowing into the altitude chamber.

14. The VENT FLOW manometer (L3) has a range of 0 to 12.0 inches H₂O. It indicates the amount of supply pressure or ambient air to the suit simulator tank.

TEST STAND CONNECTIONS

Several connections are incorporated in the test stand (fig. 11- 1) for supplying and bleeding pressure to and from the system. These connections are:

1. The N₂ INPUT connector (15) is the N₂ supply cylinder connection.

NOTE: The SYSTEM BLEED port (16) has been deleted on later configurations of Model 1172AS100 test stands.

2. The SYSTEM BLEED port (16) bleeds pressure from the various systems.

3. The N₂ INPUT connection (18) is provided for components that require inlet pressures. Either regulated high or regulated low pressures can be provided to the connection. The N₂ INPUT tee connection (28), N₂ INPUT PRESSURE gauge (27) and the gauge guard that protects the input pressure gauge are connected to N₂ INPUT connection (18).

CHECK VALVE CONNECTIONS

There are four connections located within the altitude chamber that have check valves incorporated, and require insertion of a bayonet-type fitting to open the connection and route the flow (fig. 11-1). These connections are as follows:

1. The LOW PRESSURE connection (19) provides for a controlled flow of low-pressure nitrogen through LEAKAGE CONTROL valve (E) to the item under test.

2. The 20 to 200 CCM LEAKAGE connection (20) connects the test item to OVERBOARD LEAKAGE rotameter (6), and is used when testing components for leakage or bleed.

3. The REFERENCE TAP connection (21) is a reference tap to differential pressure indicating manometers (PRESSURE/SUCTION manometer (4) and Hg manometer (5)). It also has a reference line that connects piezometer (26) into REFERENCE TAP connection (21) downstream from the check valve.

4. The HELMET REFERENCE TAP connection (24) is a reference tap connected to both suit simulator tank through SUIT SIMULATOR REFERENCE SHUTOFF valve (R) or LOW RANGE ALTM (13) through REFERENCE PRESSURE SELECTOR valve (O).

NOTE: The CHAMBER REFERENCE port (N/N), also located within the chamber, references chamber pressure to ALT CONTROLLER (B), PRESSURE/SUCTION manometer (4), Hg manometer (5), LOW RANGE ALTM (13), and HIGH RANGE ALTM (12).

Line traps, float check valves, and relief valves are not shown in figure 11-1.

Line traps are incorporated in PRESSURE/SUCTION manometer (4) and Hg manometer (5) to trap liquids in case manometers are overloaded.

The float check valves incorporated in the OUTPUT FLOW manometer (1), the INPUT FLOW manometer (2), the VENT FLOW manometer (3) and the PRESSURE/SUCTION manometer (4) help to prevent a loss of liquid in case the manometers are overloaded.

The relief valves are incorporated in the REGULATED LOW PRESSURE gauge (11) and the suit simulator tank. The relief valve on the REGULATED LOW PRESSURE gauge (11) is preset at 200 to 230 psig and protects the gauge and rotameter system in case of gauge guard failure. The PRIMARY relief valve is preset at 15 psig and the SECONDARY relief valve is preset at 25 psig. These relief valves prevent overpressurization of the suit simulator tank.

VACUUM PUMP

The VACUUM PUMP (VP) operates from a 2 horsepower electric motor (fig. 11-3). The pump rotation is clockwise, when viewed from the rear of the test stand. The pump has the capability of evacuating the chamber at a rate of 22.5 cubic feet per minute (cfm) at 81 mm Hg (51,600 feet) simulated altitude. It is used to evacuate the chamber or draw flow of air, nitrogen, or air and nitrogen from an item under test. The VACWM

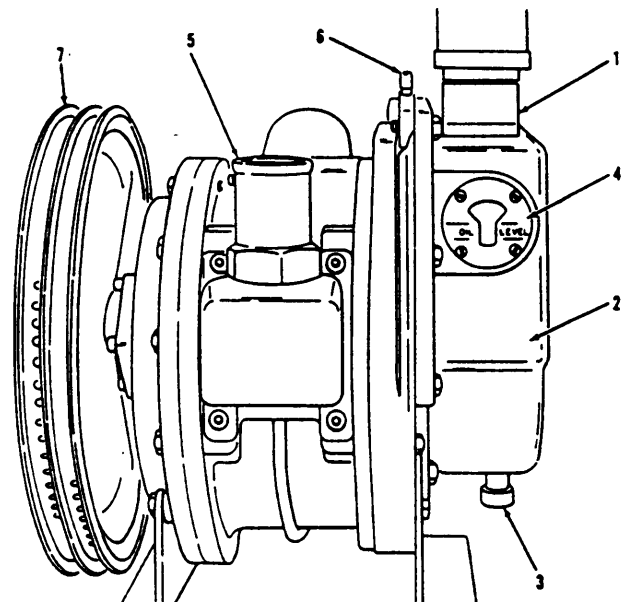

1. OIL FILL PORT (FILTER ON TOP)
2. OIL CASE COVER
3. OIL DRAIN CAP
4. OIL COVER WINDOW (SIGHT GAUGE)
5. INTAKE NIPPLE
6. VACUUM PUMP VENT
7. BELT PULLEY

239.478

Figure 11-3.—Vacuum pump.

PUMP vent (54) must be opened one to two turns when you operate the pump (fig. 11-1).

WARNING

ALWAYS ENSURE THAT THE PUMP MOTOR HAS A FOUR-PRONG ELECTRICAL CONNECTION PLUG. ON MODEL 1172AS100 ENSURE THAT THE GROUNDING LUG IS IN PLACE AND SECURELY CONNECTED. A SIDE VIEW OF THE VACUUM PUMP IS SHOWN IN FIGURE 11-3.

SAFETY PRECAUTIONS

Before you attempt to operate the test stand, review the following safety precautions. These safety precautions must be observed before, during, and after test stand operation.

1. Ensure that the test stand is properly secured prior to opening the supply cylinder valve. Position the HIGH PRESSURE REGULATOR to LOAD, then to VENT, and ensure that the LOW PRESSURE REGULATOR is backed out and the other valves are turned fully to the right.
2. Keep the chamber door closed whenever possible.
3. Keep the test stand doors closed at all times.
4. Keep the test stand work tray closed when it is not in use.
5. Check the pump lubricant prior to turning the pump on (run for 2 minutes and check lubricant for proper level).
6. Keep your hands and head clear of belts and pulleys while checking the lubricant level.
7. Ensure the test stand is properly grounded by using the grounding lug.
8. Never use regulated high pressure and regulated low pressure together.
9. When the oxygen monitor alarm sounds, leave the room.
10. Do not panic when the test stand malfunctions.
11. When you use nitrogen, ensure that the room is well ventilated.
12. Use proper tools for the job you are performing.
13. Do not inhale lubricant, oxygen cleaning compound, or mercury fumes.
14. Wash pump lubricant or mercury from hands immediately.

15. Secure the test stand completely after use.
16. Never leave the test stand unattended while the pump is running.

17. When transporting the compressed nitrogen cylinder, you should ensure the protective cap is on.

MAINTENANCE

Maintenance on the oxygen components test stand is discussed in the following paragraphs.

MANOMETER PREPARATION

Maintenance on the 1172AS100 begins as soon as the test stand is uncrated. You should fill the OUTPUT, INPUT, and VENT FLOW manometers with a liquid that has a known specific gravity of 1.0. The liquid used for the 1172AS100 is a mixture of one part concentrated green manometer fluid (merian D-2930) mixed with 10 parts of water. To fill the manometers, your first step is to adjust the scale so that the zero is located half way between the full-up and the full-down position.

Remove the fill plugs from the manometer reservoirs and fill the reservoir until the fluid reaches the zero mark on the scale. After you have filled the reservoir to zero, replace the fill plugs.

To fill the pressure suction manometer with fluid, use red manometer fluid with a specific gravity of 1.9. The procedure is the same. Adjust the scale so the zero mark is half way between the full-up and full-down positions. You have one more type manometer to fill. The Hg manometer uses triple-distilled mercury. To fill this manometer, follow the same procedure that you used for the other manometers. Do not spill the mercury. If you do, notify your supervisor, and follow the special precautions for cleaning mercury spills.

PRESSURE/LEAKAGE TESTS

To ensure maximum operating efficiency, pressure/leakage tests must be performed periodically.

NOTE: Use systems schematic drawings as an aid in determining any malfunctions that may exist. You can find these schematics in NAVAIR 13-1-6.4.

Outward Leakage Test (Supply System)

The outward leakage test (fig. 11-1) is performed as follows:

1. Ensure the supply cylinder valve and all test stand valves are closed.
2. Open fully, then close the supply cylinder valve.
3. Note the pressure registered on gauge (9). After 2 minutes, reread the pressure on gauge (9). There should be no pressure drop (a drop in pressure indicates leakage).

Outward Leakage Test (Regulated High-Pressure System)

The outward leakage test is performed as follows:

1. Cap connection (18) in chamber.
2. Open supply cylinder valve.
3. Turn regulator (Q) to LOAD, and hold until 2,000 psig (or cylinder pressure) is indicated on gauge (10). The regulated low-pressure gauge should indicate the gauge guard cut-off pressure, 170 ± 5 psig.)
4. Close the supply cylinder valve and note the pressure on gauge (10). After 2 minutes, reread gauge (10). There should be no pressure drop (a drop in pressure indicates leakage).

NOTE: If pressure is registered on gauge (27), a leak is indicated in ON/OFF valve (L) or ON/OFF valve (G). A pressure drop on gauge (11) also indicates valve (G) is leaking. Valve (G) will be independently tested later.

Bleed pressure by turning (Q) to VENT. Open valve (S) to bleed system, then close valve (S).

Outward Leakage Test (Regulated Low-Pressure System)

The outward leakage test is performed as follows:

1. Open the supply cylinder valve. Turn the selector valve (F) to HIGH and the selector valve (D) to Hg.
2. Turn the ON/OFF valves (L) and (G) to ON.
3. Slowly turn the regulator (N) clockwise until 70 psig is indicated on gauges (1 1) and (27).

4. Return valve (L) to OFF and observe rotameter (8). Any leakage will be indicated by the ball rising in the rotameter tube. There should be no leakage.

5. Turn valve (F) to LOW RANGE position and observe rotameter (7). There should be no leakage.

6. Return valve (F) to HIGH RANGE, and valve (L) to ON.

7. Slowly adjust the regulator (N) until 160 psig is registered on gauge (11). Gauge (27) should indicate its gauge guard cut-off pressure of 145 ± 5 psig.

8. Turn the ON/OFF valve (L) to OFF and observe rotameter (8). There should be no leakage indicated.

9. Turn the selector valve (F) to LOW RANGE and observe rotameter (7). There should be no leakage indicated.

10. Decrease the pressure to 70 psig by opening valve (S), and turning regulator (N) in a counterclockwise direction.

Leakage Control Valve (E) and Leakage ON/OFF Valve (G) Tests

Perform leakage control valve and leakage ON/OFF valve tests as follows:

1. Connect a hose from connection (19) to tap (20) in the chamber, and observe rotameter (6). There should be no leakage indicated.

2. Turn the ON/OFF valve (G) to OFF and remove the cap from connection (18) in chamber.

3. Observe rotameter (7). There should be no leakage indicated.

Suit Simulator System Leakage Tests

Perform leakage tests on the suit simulator system as follows:

1. Open the shutoff valve (R) and valve (J) fully. Place the selector valve (O) to the ALT CHAMBER, and valve (M) to the suit simulator position.

2. Remove the hose from tap (20) and connect it to tap (21) (connecting connection (19) to tap (21)). Cap piezometer (26).

3. Place selector valve (D) in the H₂O position, and valve (F) in the HIGH RANGE position.

4. Open valve (E) slowly to maintain a pressure of 10.0 inches H₂O throughout the system as indicated on manometer (4). Close valve (E). Any further climb on manometer (4) indicates a leak through valve (H).

5. Open valve (E) to maintain 20.0 in. H₂O. When pressure is constant, observe rotameter (8). There should be no leakage.

6. Turn valve (F) to LOW RANGE. The rotameter (7) should indicate no leakage.

7. Return valve (F) to HIGH RANGE, and close valve (E). Remove the hose from connection (19) and allow the pressure to escape from the hose.

NOTE: Open valve (C) to aid in relieving pressure; then close it.

8. When the pressure has equalized, connect the hose from tap (21) to tap (20) in the chamber. Rotameter (6) should show no indication of leakage.

9. Remove the cap from Piezometer (26), and disconnect the hose between taps (20) and (21) in the chamber.

10. Turn the regulator (N) counterclockwise, and open valve (S) to bleed system. Close all test stand valves with the exception of valves (R) and (J).

Altitude Chamber and Suit Simulator Tank Inward Leakage Test

Perform the altitude chamber and suit simulator tank inward leakage test as follows:

1. Place valve (D) in the Hg position. Ensure the ON/OFF valves (G) and (L) are in the OFF position. Place valve (0) in the suit simulator position.

2. Close the chamber door and turn the vacuum pump motor ON.

3. Open the VACUUM CONTROL valve (B₁) and "ascend" to 30,000 feet. Close (B₁) and check to ensure that the same altitude is indicated on both altimeters (12) and (13). At 30,000 feet you will see the high-range altimeter start to climb and at 40,000 feet the low-range altimeter will no longer be in use. This happens automatically and the low-range altimeter will not be damaged.

4. Using valve (B₁) "ascend" to 40,000 feet; ensure that altimeters (12) and (13) register the same altitude.

5. Using the VACUUM CONTROL valve (B₁), ascend to 52,000 feet. (Altitude is indicated on altimeter (12).)

6. Close (B₁); after a 2-minute stabilization period, record the altitude indicated on altimeter (12). Altitude "loss" should not exceed 1000 feet in 20 minutes.

PERIODIC INSPECTIONS

Periodic inspections consist of daily, weekly, biweekly, and monthly inspections. Perform these inspections at the prescribed intervals using the procedures described in the following text.

Daily Inspection

Perform the daily inspection as follows:

1. Check the vacuum pump lubricant for the proper level (run the pump for 2 minutes and recheck for proper level).

2. Inspect the gauges and manometers for cleanliness, fogged or broken glass, and zero or normal indications.

3. Inspect the altitude chamber door for cleanliness, chips, scratches or cracks. Check the gaskets for excessive wear or deterioration.

4. Inspect the connections and adapters for cleanliness and distortion.

5. Check the identification plates for cleanliness, legibility, and security of attachments.

Weekly Inspection

The weekly inspection includes all the tasks of the daily inspection and the following additional tasks:

1. Inspect the polyethylene tubing, fittings, connections, and rubber couplings for the correct fit, dirt or excessive dust, pin holes, radical bends or kinks, surface abrasions and heat blisters.

2. Inspect the gauges, manometers, and flowmeters for the correct calibration decals, proper fluid level, and cleanliness of manometer and flowmeter tubes.

3. Perform the pressure leakage tests in accordance with NAVAIR 13-1-6.4.

Biweekly Inspection

The biweekly inspection includes all the tasks of the weekly inspection and the following additional tasks:

1. Inspect the pump drive belt for proper tension, pulley alignment, excessive belt wear, and tightness of pulley setscrews.
2. Perform the orifice calibration check in accordance with AVAIR 13-1-6.4.
3. Perform the flowmeter intercomparison test in accordance with NAVAIR 13-1-6.4.

Monthly Inspection

The monthly inspection includes all the tasks of the biweekly inspection and the following additional tasks:

1. Inspect the N₂ and air inlet connectors for dirt, foreign matter, corrosion, stripped threads, and badly scuffed surfaces.
2. Inspect the gaskets at bulkhead fittings and vacuum pump filters for deterioration and proper fits and alignments.
3. Inspect the copper tubing for corrosion and tightness of soldered joints.
4. Inspect the altitude chamber for cleanliness, proper fit and alignment of gaskets, excessive scratches on chamber door, leaks or corrosion at pipe fittings, and wear of the door gasket.
5. Inspect all tubing and piping for tightness and proper alignment.
6. Inspect all electrical plugs, connectors, and wiring for physical damage, bent pins, loose connections, and security of cables.
7. Inspect all control valves for cleanliness and tightness of mounting nuts and knobs.

VOL-O-FLO CALIBRATION

The intercomparison test compares the input and output Vol-O-Flo elements to determine if the flowmeters need calibration. It is performed more often than the orifice calibration test as it is quicker and easier to perform.

The orifice calibration check accurately determines whether the output Vol-O-Flo is within calibration tolerances.

When a test stand fails the intercomparison test, an orifice calibration check is performed. Failure of the intercomparison test and orifice

calibration check requires the removal and cleaning of the input and output Vol-O-Flo elements.

NOTE: Prior to performing these calibration checks, you should ensure that there is no test stand leakage.

After cleaning, drying, and reinstallation of the Vol-O-Flo elements, both the intercomparison test and the orifice calibration check must be repeated. Failure of the above tests after cleaning will require the test stand be calibrated with a master calibrator, used by the metrology calibration team.

VOL-O-FLO ELEMENT CLEANING

To clean the Vol-O-Flo element, proceed as follows:

1. Disconnect the tubes from Vol-O-Flo manometers.

NOTE: Prior to removal of the element, mark the direction of the flow to ensure proper reinstallation.

2. Disconnect the element from the plumbing system by removing the hose and hose clamps at the ends of the element.
3. Mix a cleaning solution of 4 percent liquid detergent and water. (Mix 6 ounces of detergent with 1 gallon of water.)
4. Flush the element in reverse from the direction in which the air normally flows.
5. After the element has been well flushed, the detergent is rinsed out immediately with clean water.
6. Install the element in the test stand, and create a flow through the element for approximately 1 hour to ensure that it is completely dry.
7. After the element is dried, the test stand is leak-tested.
8. Perform an intercomparison test and orifice calibration check in accordance with the NAVAIR 13-1-6.4.

LIQUID OXYGEN CONVERTER TEST STANDS

Liquid oxygen converters are another group of items that you, as a PR, are required to test and repair. There are two test stands designed to test the oxygen converters. The operation, maintenance, and parts are, with a few minor

exceptions, basically identical. The part numbers for the two test stands are 59A120, manufactured by Aerojet-General Corporation, and the 31TB1995-1, manufactured by Pioneer.

FUNCTIONS

The 59A120 test stand (fig. 11-4) is designed to test liquid oxygen converters, components, and

rigid seat survival kit (RSSK) components. This function is accomplished by the converter routing a test gas through various valves, gauges, and tubing to the item under test.

Bell Jar

The bell jar is used for testing components having more than one possible area of leakage.

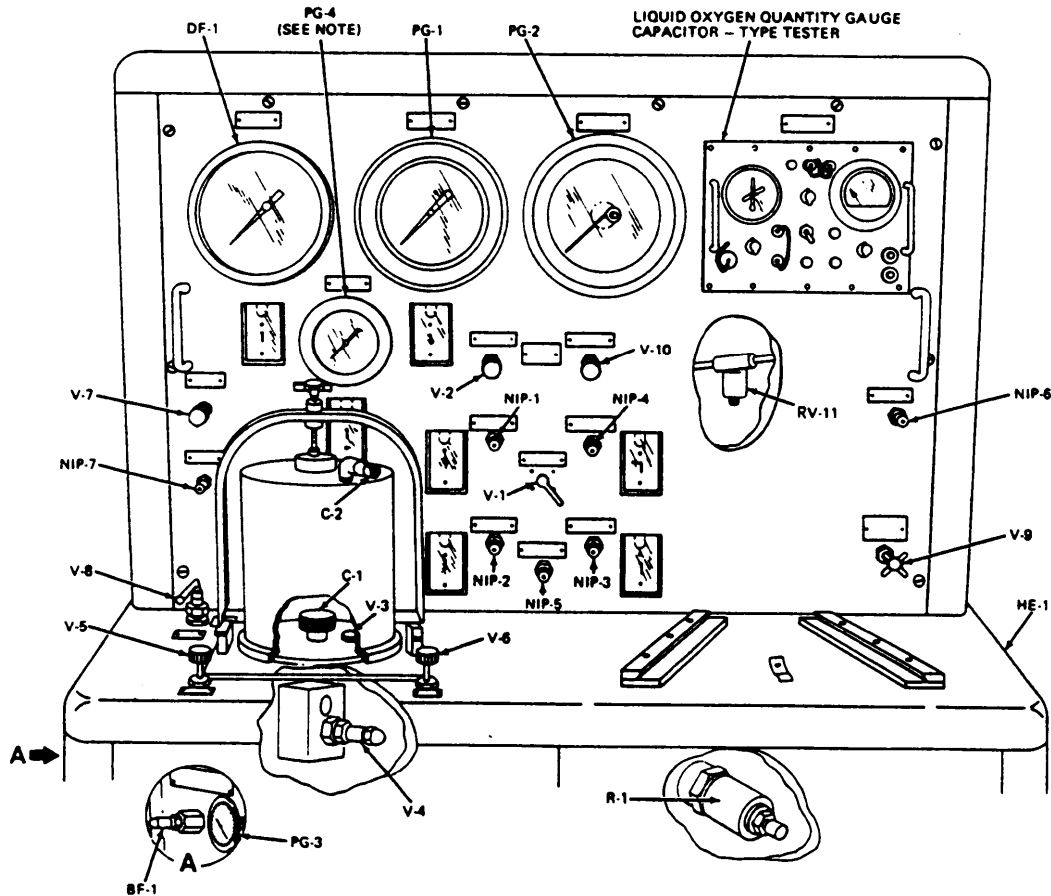

- | | | | |
|--------------|---|--------------|---|
| 1 | Correction Card Holder | PG-3 | 0-3000 PSIG Supply Pressure Gauge |
| BF-1 | Special Bulkhead Fitting | PG-4 | 0-15 PSIG Low Pressure Test Gauge (See Note) |
| C-1 | Bell Jar Bottom Coupling | R-1 | 0-160 PSIG Oxygen Pressure Regulator |
| C-2 | Bell Jar Top Coupling | V-1 | Flowmeter Selector Valve |
| DF-1 | 0-100 INH₂O Differential Pressure Gauge | V-2 | Test Pressure Gauge To Bell Jar Valve |
| HE-1 | Heat Exchanger (Not Shown) | RV-3 | 5-15 PSI Relief Valve (Set At 5 PSI) |
| NIP-1 | 0-0.25 LPM Flowmeter Connection | RV-4 | 0-500 PSI Relief Valve (Set At 180 PSI) |
| NIP-2 | 0-1 LPM Flowmeter Connection | V-5 | System Bleed Valve |
| NIP-3 | 0-50 LPM Flowmeter Connection | V-6 | Oxygen Supply Valve |
| NIP-4 | 0-150 LPM Flowmeter Connection | V-7 | Differential Pressure Bleed Valve |
| NIP-5 | Converter Supply Outlet Connection | V-8 | Differential Pressure Shut-Off Valve |
| NIP-6 | Supply To Converter Connection | V-9 | Converter Supply Flow Control Valve |
| NIP-7 | Differential Pressure Gauge Connection | V-10 | Test Pressure Gauge Build-Up And Flow Valve |
| PG-1 | 0-160 PSIG Test Pressure Gauge | RV-11 | 100-120 PSI Relief Valve (Set At 110 PSI) |
| PG-2 | Flowmeter Indicator Gauge | | |

NOTE: 59A120 ONLY

Figure 11-4.—Liquid Oxygen Converter Test Stand 59A120 control panel and counter top.

239.550

It consists of a relief valve RV-3, the bell jar itself, and the bell jar top coupling C-2 (fig. 11-4). When operating properly, the relief valve RV-3 has a range of 5 to 15 psig. It is leaktight at 5 psi, and is set to relieve at 10 psi.

Differential Pressure Gauge, DF-1

The differential pressure gauge is a bellows-operated gauge that operates in the range of 0-100 inches H₂O (inches of water). The gauge indicates differential pressure when testing pressure closing and opening valves.

Relief Valve, RV-11

The converter section of the test stand is protected from excessive pressure by the RV-11 relief valve. This relief valve is set to relieve pressure in excess of 110 psig.

Converter Supply Connection, NIP-6

The converter supply connection NIP-6 connects the converter supply coupling, through the use of a hose, to the test stand. The flow of oxygen shown in figure 11-5 shows that the

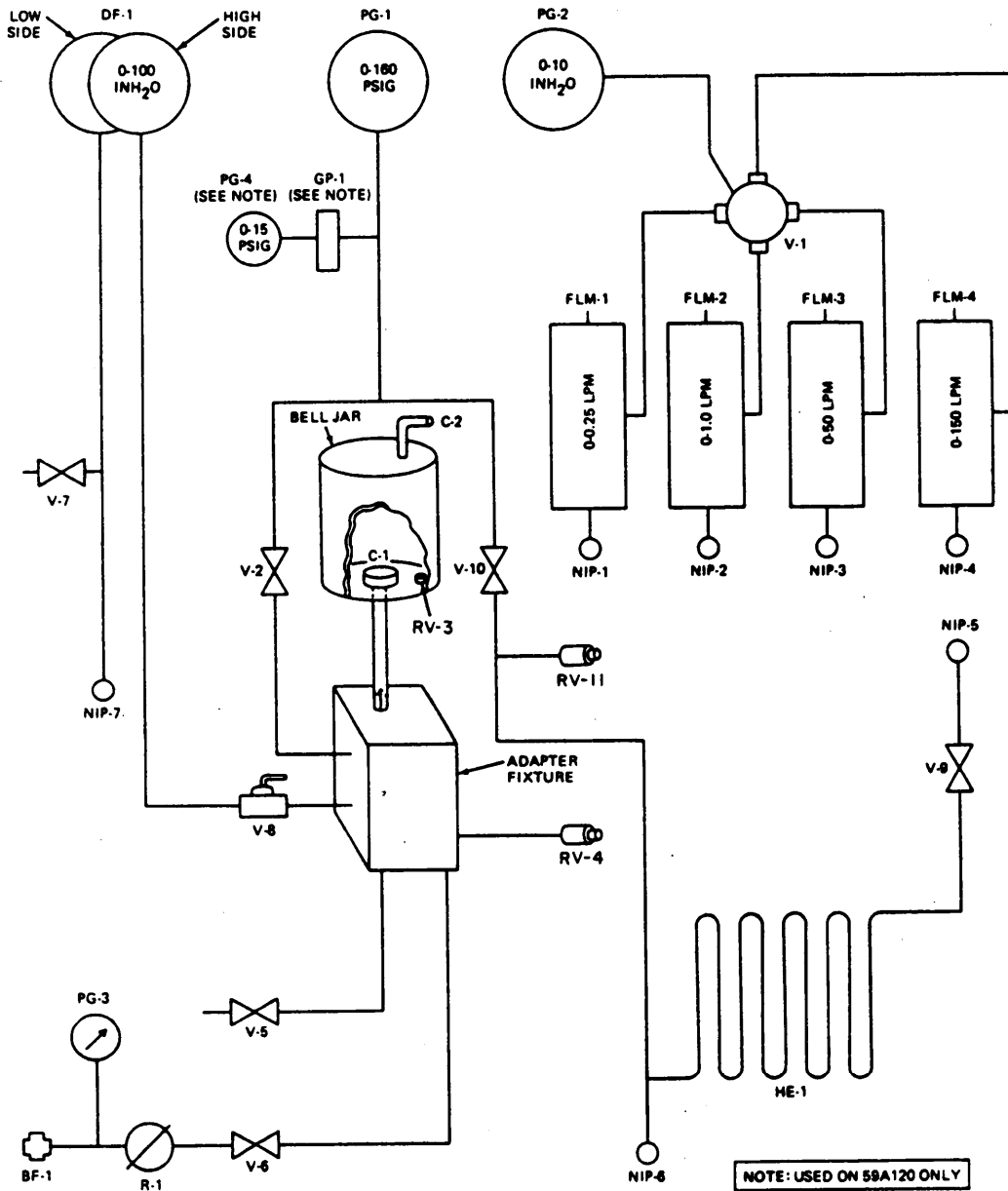

Figure 11-5.—Test stand schematic.

converter supply flow control valve V-9 controls the flow of oxygen from the liquid oxygen converter through the heat exchanger HE-1 to the buildup and flow valve V-10, and then to the adapter fixture.

Linear Flow Elements

There are four linear flow elements. Each measures a different flow rate in liters per minute (LPM). By using a hose assembly connected from NIP-5 (converter supply outlet connection) to the correct one of the linear flow elements (NIP-1 for 0-00.25 LPM, NIP-2 for 0-1.0 LPM, NIP-3 for 0-50 LPM, or NIP-4 for 0-150 LPM), and turning the flowmeter selector valve, you can measure leakage from an item under test.

Liquid Oxygen Quantity Gauge Capacitor-Type Tester

The liquid oxygen quantity gauge capacitor-type tester is located on the upper front panel of the test stand and operates on 115 Vat, 400-cycle current. It is used to measure capacitance and electrical insulation of the capacitance probe.

Flow of Oxygen

As you turn on the supply of gas, it flows into the test stand through a special bulkhead fitting BF-1 (fig. 11-4), and it is indicated on the 0-3,000 psig pressure gauge PG-3. It then flows to the adjustable pressure regulator R-1. The regulator is preset to deliver 160 psig to the remainder of the test stand through oxygen supply valve V-6. Oxygen supply valve V-6, a needle-type valve, admits oxygen to the adapter fixture and controls oxygen pressure to an item under test. From the adapter fixture, the test gas is routed to the following valves, gauges, and disconnects:

Test gas enters the bell jar bottom coupling C-1. Your test item is also attached to this coupling. From C-1 it flows to the needle metering valve V-2, which allows the flow to continue to a test pressure gauge PG-1.

NOTE: When opening valve V-2, you must close valve V-10. This prevents oxygen from entering the converter side of the test stand.

The test pressure gauge PG-1 indicates the pressure applied to the item under test. The oxygen flow also goes from the adapter fixture

to the differential pressure gauge shutoff valve V-8. This valve prevents pressure from being admitted to the high side of the differential pressure gauge DF-1 when the gauge is not being used. Another flow from the adapter fixture is to the system bleed valve V-5. This valve is a needle-type valve, and it is used to bleed the pressure from the test stand. On every test stand you will find a safety valve. In this case, we have a relief valve V-4 that prevents excessive pressure buildup in the test stand. The valve is leaktight at 160 psig, and is set to relieve at 180 psig.

MAINTENANCE

Maintaining and preparing the test stand for use is divided into five separate tasks: installation, visual inspection, correction card preparation, calibration, and leak testing. These tasks, fully described in the following paragraphs, are outlined briefly below:

1. Installation includes selecting a suitable space, mounting, connecting to a suitable power supply, and an oxygen source.
2. The visual inspection is performed to ensure the test stand has not been damaged during shipment and installation.
3. Correction/calibration cards (fig. 11-6) provide an easy reference upon which indicated flows and pressures are recorded. Actual mandatory flows and pressures are taken from NAVAIR 17-15BC-20 and are prerecorded on the correction/calibration cards. The actual LPM flow must be converted to the indicated inches of H₂O flow and to millimeter (mm) flow by using the applicable flowmeter calibration graphs. This conversion is performed by the metrology calibration team.

NOTE: Additional actual pressures and flows have been added to the correction cards in figure 11-6. Addition of these pressures and flows reflect required actual pressures and flows needed to bench test RSSK kits and all models of LOX converters now in service.

4. Periodic leakage tests are conducted on the accessories section, bell jar assembly, and the entire test stand.
5. Calibration of the test stand is required to be performed prior to use. Calibration procedures are performed at 6-month intervals by the onsite metrology calibration team. Additional calibrations are not required.

CORRECTION CARD NUMBER 1	
ACTUAL IN. H ₂ O	INDICATED IN. H ₂ O
100	
80	
60	
40	
20	
10	

CORRECTION CARD NUMBER 2	
ACTUAL PSIG	INDICATED PSIG
160	
140	
130	
120	
110	
100	
95	
90	
85	
80	
76	
70	
60	
55	
40	
35	
30	
25	
20	

CORRECTION CARD NUMBER 3	
ACTUAL PSIG	INDICATED PSIG
14	
12	
10	
8	
6	
4	
2	

CORRECTION CARD NUMBER 4		
ACTUAL LPM	INDICATED IN. H ₂ O	MM
150		
122		
120		
100		
90		
75		
50		

0-150 LPM

CORRECTION CARD NUMBER 5		
ACTUAL LPM	INDICATED IN. H ₂ O	MM
40		
30		
20		
10		
5		
3		

0.0-50 LPM

CORRECTION CARD NUMBER 6		
ACTUAL LPM	INDICATED IN. H ₂ O	MM
1.0		
0.75		
0.50		
0.25		

0.0-1.0 LPM

CORRECTION CARD NUMBER 7		
ACTUAL LPM	INDICATED IN. H ₂ O	MM
0.20		
0.15		
0.10		
0.08		
0.07		
0.06		
0.05		
0.03		
0.02		
0.01		

0.0-0.25 LPM

Figure 11-6.—Calibration correction cards.

Installation

The test stand may be installed in any convenient location. Table 11-1 includes nominal dimensions of the test stand. Total space requirements can be determined by adding a reasonable working area to the dimensions given in the table.

NOTE: The test stand has drilled flanges to allow stable mounting. If shock pads are placed under the stand, they must extend under the whole stand to give even distribution of support.

Power requirement for the test stand is 115 Vat, 400-cycle, single-phase service. The test stand is connected to a suitable power source by the electrical cable assembly.

A 300 to 2,000 psig oxygen source is required. A metal strap on the left rear of the test stand is provided for mounting and securing the oxygen supply cylinder.

Visual Inspection

Visually inspect the test stand for the following:

1. Dial glasses for cracks or breakage
2. All hoses for cracks or breaks
3. All pipe and hose fittings for security of connection, worn, stripped or crossed threads
4. All tubing for severe dents or punctures
5. All valves for body cracks
6. Heat exchanger for rupture, severe dents, or punctures
7. Gauge tester for damaged or loose parts, and tightness of terminals and connectors

Any components found to be damaged or defective should be repaired or replaced. Refer to NAVAIR 17-15BC-20 for part numbers.

Test Stand Leakage Tests

Test stand leakage tests are performed by personnel attached to the oxygen shop and consist of setting the oxygen pressure regulator, leak testing the accessories section, test stand section, and Bell Jar assembly.

SETTING THE OXYGEN PRESSURE REGUIATOR.— To set oxygen pressure regulator

Table 11-1.—Test Stand Installation

LEADING PARTICULARS			
Width (in.)	Depth (in.)	Height (in.)	Weight (lb)
50.12	24.06	68.06	460
GENERAL TECHNICAL CHARACTERISTICS			
Indicator		Range	
Supply Pressure Gauge		0 to 3000 psig	
Test Pressure Gauge		0 to 160 psig	
Low Pressure Test Gauge (59A120 only)		0 to 15 psig	
Differential Pressure Gauge		0 to 100 in H ₂ O	
Flowmeter Indicator		0 to 10 in H ₂ O	
Leakage Linear Flow Element No. 1		0 to 0.25 liters per minute (lpm)	
Leakage Linear Flow Element No. 2		0 to 1.0 lpm	
Rate Linear Flow Element No. 1		0 to 50 lpm	
Rate Linear Flow Element No. 2		0 to 150 lpm	
Liquid Oxygen Quantity Gauge Capacitor-Type Tester			
Capacitance measuring			
range		0 to 5,000 uuf in four ranges.	
accuracy		± 0.5% of reading or 0.25% of maximum value of applicable capacitance measuring range, whichever is greater.	
Insulating resistance measuring			
range		0 to 10,000 megohms in four ranges.	
accuracy		± 0.125 inch of scale length.	
Maximum voltage at test terminals		Less than 50 Vac.	
Short Circuit Current of test terminals		Less than 200 milli-amperes.	

R-1 to maintain 160 psig with 1,800 psig supply pressure applied, proceed as follows:

CAUTION

VALVES V-2, V-5, V-6, V-7, AND V-10 ARE METERING (NEEDLE) VALVES. OVERTIGHTENING THESE VALVES WILL DAMAGE THE VALVE SEAT. ONLY FINGERTIGHT PRESSURE SHOULD BE USED WHEN YOU CLOSE THESE VALVES.

1. Ensure that all test stand valves are closed, and plug the bell jar bottom coupling C-1.

WARNING

WHEN YOU WORK WITH OXYGEN, MAKE CERTAIN THAT CLOTHING, TUBING FITTINGS, AND EQUIPMENT ARE FREE OF OIL, GREASE, FUEL, HYDRAULIC FLUID, OR ANY COMBUSTIBLE MATERIALS. FIRE OR EXPLOSION MAY RESULT WHEN EVEN SLIGHT TRACES OF COMBUSTIBLE MATERIAL COME IN CONTACT WITH OXYGEN WHEN IT IS UNDER PRESSURE.

2. Open the oxygen supply cylinder valve.

NOTE: When you set regulator R-1, a MINIMUM of 1,800 psig of oxygen pressure is applied to the regulator.

3. Open the test pressure gauge to bell jar valve V-2 slowly, and fully open the oxygen supply valve V-6.

4. Loosen the hex locknut located on the front of regulator R-1. Turn the T-handle until 160 psig registers on the test pressure gauge PG-1. Tighten the hex locknut, and your oxygen pressure gauge is now set.

5. Close the oxygen supply cylinder valve and open the system bleed valve V-5 to bleed pressure from the system. After bleeding the pressure, remove the plug from the bell jar bottom coupling C-1.

LEAKAGE TEST, ACCESSORIES SECTION.— TO perform the leakage test on the

accessories section of the test stand, proceed as follows:

1. Install the nipple assembly in the bell jar bottom coupling C-1. Connect one end of the hose to the adapter, and the other end to the differential pressure connection NIP-7.

2. Ensure that the test pressure gauge to bell jar valve V-2 is open. The system bleed valve V-5, the test pressure gauge buildup, and the vent valve V-10 and the differential pressure bleed valve V-7 are closed.

3. Open the differential pressure shutoff valve V-8 and the oxygen supply cylinder valve.

4. Slowly open the oxygen supply valve V-6 until 160 psig is indicated on test pressure gauge PG-1.

5. Now close the oxygen supply valve V-6. Leakage will be indicated by a drop in pressure on PG-1. Leakage should not be more than 2 psig in 10 minutes.

6. Leave all hoses and valves in their present position and start your test stand leakage test.

LEAKAGE TEST, TEST STAND.— TO perform the leakage test on the entire test stand proceed as follows:

1. Open the converter supply flow control valve V-9 and test pressure gauge buildup and the flow valve V-10.

2. Plug the converter supply outlet NIP-5 and the supply converter connection NIP-6. Ensure that the system bleed valve (V-5) is closed.

3. Open the supply valve V-6 until the relief valve RV-11 unseats. (The relief valve is set to relieve at approximately 110 psig, and be leaktight at 100 psig.) Using the system bleed valve V-5, decrease pressure until 100 psig is indicated on test pressure gauge PG-1. Close valve V-6. Leakage will be indicated by a drop in pressure on PG-1. Leakage should be no more than 10 psig in 10 minutes.

4. Bleed the test standby opening the system bleed valve (V-5). Close all the test stand valves. Remove the plugs from the converter supply outlet NIP-5 and the plug from the supply converter connection (NIP-6).

BELL JAR ASSEMBLY LEAKAGE TEST.— To perform a leakage test on the bell jar assembly, proceed as follows:

1. Remove the hose assembly and the nipple assembly from the bottom bell jar coupling C-1. Disconnect the opposite end of the hose from differential pressure connection NIP-7.

Table 11-2.-Troubleshooting Chart

TROUBLE	PROBABLE CAUSE	REMEDY
0-160 psig pressure gauge (PG-1) indicates low consistently	Leaky fittings	Perform leak test as instructed in NAVAIR 13-1-6.4 and tighten fittings as necessary.
0-160 psig pressure gauge (PG-1) indicates high	Pressure gauge (PG-1) pointer not zeroed	Request onsite metrology calibration team to adjust pressure gauge zero.
0-160 psig pressure gauge (PG-1) pointer pegs	Pressure regulator (R-1) setting incorrect	Adjust regulator setting as instructed in NAVAIR 13-1-6.4.
(59A120 only) 0-15 psig pressure gauge (PG-4) indicates low consistently	Leaking fittings	Perform leak test as instructed in NAVAIR 13-1-6.4 and tighten fittings as necessary.
(59A120 only) 0-15 psig pressure gauge (PG-4) indicates high	Pressure gauge (PG-4) pointer not zeroed	Request onsite metrology calibration team to adjust pressure gauge zero.
0-100 in H ₂ O differential pressure gauge (DF-1) indicates high	Pressure gauge (DF-1) pointer not zeroed	Request onsite metrology calibration team.
0-100 in H ₂ O differential pressure gauge (DF-1) indicates low	Leaky shut-off differential pressure valve (V-8)	Perform leak test as instructed in NAVAIR 13-1-6.4 and tighten fittings or replace valve.
Linear flow element (FLM 1, 2, 3, or 4) indicates low consistently	Defective flow element	Request onsite metrology calibration team to recalibrate flow element.
	Defective flowmeter indicator (PG-2)	Check flowmeter indicator (PG-2) for leaks or friction.
Flow element (FLM 1, 2, 3, or 4) indicates correctly over part of scale only	Defective flow element	Request onsite metrology calibration team to recalibrate flow element.
	Defective flowmeter indicator (PG-2)	Check flowmeter indicator (PG-2) for leaks or friction.

2. Ensure that the differential pressure bleed valve V-7, the test pressure gauge to bell jar V-2, and the system bleed valve V-5 are closed. Open the differential pressure shutoff valve V-8.

3. Place the bell jar on the adapter fixture and secure it with a clamp. Now plug the bell jar top coupling C-2.

4. Open the oxygen supply valve V-6 slowly until 100 inches of H₂O is indicated on the differential pressure gauge DF-1. By closing valve V-6, leakage will be indicated by a drop in pressure on DF-1. There must not be more than 2 inches of H₂O in 10 minutes.

5. Close the oxygen supply cylinder valve and open the system bleed valve V-5 to bleed the system.

6. Secure all test stand valves. Leave the system bleed valve V-5 open.

CAUTION

WHEN THE TEST STAND IS SECURED, ALL VALVES WITH THE EXCEPTION OF THE SYSTEM BLEED VALVE V-5 MUST BE CLOSED. VALVE V-5 IS LEFT OPEN TO PREVENT THE ACCIDENTAL BUILDUP OF PRESSURE IN THE SYSTEM.

CLEANING

Clean all external parts, test adapters and connections, gauge glasses, bell jar, O-ring, and terminals of the liquid oxygen quantity gauge capacitor-type tester with a soft, lint-free cloth. The cloth may be dampened with oxygen cleaning compound (MIL-C-81302).

PERIODIC INSPECTIONS

Periodic leakage inspections are required to be performed weekly. A pressure regulator (R-1) setting must be performed weekly also. In addition to the inspection requirements, the test stand should be visually inspected for cleanliness, freedom from oil and grease, missing or damaged parts, and general condition.

TROUBLESHOOTING

Refer to table 11-2, Troubleshooting Chart, for probable trouble causes and remedies. Information in this chart is intended primarily to aid oxygen shop personnel in diagnosing problems most likely to be encountered in their daily use of the test stand. Refer to NAVAIR 17-15BC-20 for parts removal and replacement.

Upon completion of any maintenance actions, complete the maintenance forms outlined in the NAVAIR 13-1-6.4.

CHAPTER 12

OXYGEN-RELATED COMPONENTS

Learning Objective: Upon completion of this chapter, you will be able to identify, maintain, and perform maintenance on oxygen regulators and liquid oxygen converters.

Oxygen regulators are used in all naval aircraft. They supply the aircrew member with the necessary oxygen to perform all flying duties under all kinds of conditions. As a PR, you will maintain, service, and test oxygen regulators and liquid oxygen converters. This chapter will give you a basic idea of how a miniature oxygen regulator functions, as well as a panel-mounted regulator and a liquid oxygen converter. It will also cover some of the maintenance that you must perform. The miniature regulator shown in figure 12-1 is a model 29267-A1, type CRU-79/P, and this model is manufactured by Bendix Aviation Corporation. Other models are manufactured by Clifton Precision, Robert Shaw Controls Company and ARO Corporation, but all are type CRU-79/P. They are designed to regulate 100-percent oxygen to the aircrew member during flight. Table 12-1 contains the leading particulars for the regulator.

The miniature regulator reduces and regulates supply oxygen pressure to provide an adequate amount for breathing under a variety of conditions. It has a safety-pressure feature that automatically maintains a positive pressure in the aircrew members mask of 0.50 to 2.5 inches of water above the surrounding air pressure. (Inches of water is a means of measuring the comparatively low pressure used in testing oxygen regulators.) This positive pressure is maintained at all altitudes up to and including 34,000 feet. Above that altitude, the pressure-breathing feature maintains a positive pressure in the mask of up to 18.0 inches of water at altitudes between 34,000 and 50,000 feet, with the positive pressure increasing in proportion to the altitude. Miniature regulators can be used routinely up to approximately 43,000 feet. However, due to human limitations, miniature regulators should

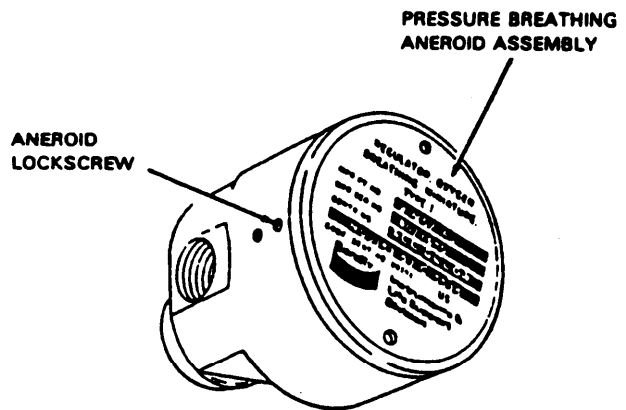

Figure 12-1.-Miniature oxygen breathing regulator model 29267-A1.

Table 12-1.-Leading Particulars for Miniature Oxygen Breathing-Regulator Type CR79/P

Recommended Inlet Pressure	40 to 120 psig
Flow	0 to 100 lpm
Operating Altitude Range	0 to 50,000 feet
Operating Temperature Range	-65 °F to +160 °F
Weight	3.5 ounces

not be used above 43,000 feet except for very short periods.

Miniature regulators are designed for use with the MBU-14 series oxygen mask as part of the oxygen system in all aircraft requiring 100-percent oxygen chest-mounted regulators. Refer to the NAVAIR 13-1-6.7 manual for personal configurations of the MBU-14 series oxygen mask.

MAINTENANCE

Maintenance of the type CRU-79/P regulator is limited to inspection, testing, adjustment of the pressure breathing aneroid, and tightening of loose screws. Ensure that antiseize tape is used on pipe threads. This section contains only the procedural steps necessary to meet these requirements.

NOTE: Upon completion of any maintenance action (for example, inspection, adjustment, modifications, etc.), be sure to complete the required maintenance data collection system forms.

If the regulator fails any inspection or testing requirements, it must be disposed of in accordance with any local directives and replaced with a ready for issue (RFI) component.

The miniature regulator will remain in service as long as it continues to function correctly and does not require other than authorized adjustment.

Procedural steps outlined in this section are listed under the inspection cycle in which they are required, and in the sequence in which they normally occur.

DAILY/PREFLIGHT INSPECTION

The daily/preflight inspection is a visual type inspection performed by the aircrew member to whom the regulator is issued, either daily or before each flight. To perform this inspection, visually inspect the following:

WARNING

WHEN WORKING WITH OXYGEN, MAKE CERTAIN THAT CLOTHING, TUBING FITTINGS, AND EQUIPMENT ARE FREE OF OIL, GREASE, FUEL, HYDRAULIC FLUID, OR ANY COMBUSTIBLE MATERIALS. FIRE OR EXPLOSION MAY RESULT WHEN EVEN SLIGHT TRACES OF COMBUSTIBLE MATERIAL COME IN CONTACT WITH OXYGEN UNDER PRESSURE.

1. Inlet and outlet connections for security of attachment. Make sure that all clamps, locknuts, fittings and screws are tight.

2. The regulator body for dents, scratches, corrosion, cracks, condition of the nameplate, or any other damage.

3. Perform a functional test as outlined in the next inspection (special inspections).

If discrepancies are found or suspected, the regulator should be taken to the Aviator's Equipment Branch for the required corrective maintenance.

SPECIAL INSPECTIONS

Special inspections are required at specified intervals in addition to the daily/preflight or calendar inspections. The interval for miniature oxygen regulators is 30 days. This inspection consists of a visual inspection and a functional test, both performed by personnel of the Aviator's Equipment Branch. To perform the special inspection, proceed as follows:

1. Visually inspect the regulator as outlined in the previous section (daily/preflight).

2. Functionally test the regulator by attaching the mask, regulator, and delivery tube to a suitable oxygen supply source. Use a regulator-to-seat hose for an attachment.

3. Turn on the supply source. There should be a flow of oxygen through the mask.

4. Don the mask and breathe. There should be a slight resistance on exhalation. This resistance is due to the positive pressure feature of the regulator.

When you finish the special inspection, record the date and place of inspection in the 'NOTES' section of the Aircrew Personal Protective Equipment History Card.

CALENDAR INSPECTION

The calendar inspection is performed on all miniature regulators upon issue prior to being installed in an in-service personal oxygen configuration and must be performed on all miniature regulators in service at least every 90 days.

The calendar inspection consists of a visual inspection and a bench test. All work must be done in a clean, dust-free and oil-free area.

VISUAL INSPECTION

To visually inspect the miniature regulator, proceed as follows:

1. Disconnect the communication connectors.

2. Loosen the hose clamp that holds the regulator outlet to the mask delivery hose, and remove the regulator from the hose. Retain the hose clamp.

3. Loosen the locknut and remove the regulator-to-seat kit hose from the regulator inlet.

4. Inspect the regulator inlet and outlet for foreign objects, dirt, corrosion, dents, cracks, or other damage.

5. Inspect the regulator body for dents, cracks, corrosion, the condition of the nameplate, security of screws and fittings, and for other obvious damage.

Miniature regulators that fail the visual inspection or the bench test must be disposed of in accordance with any local directives.

BENCH TEST

The bench test and all other tests must be performed using an Oxygen System Components Test Stand, Model 1172AS100. Refer to chapter 11 of this training manual for identification of test stand controls and indicators referred to in the bench test procedures that follow. Do not attempt to perform any bench test before becoming thoroughly familiar with the test stand. Use a performance test sheet when performing the "bench test. See figure 12-2.

REGULATOR PERFORMANCE TEST SHEET

**MINIATURE OXYGEN BREATHING REGULATORS
TYPE CRU-79/P**

DATE: _____ REGULATOR SERIAL NO: _____ MODEL: _____

TEST STAND SERIAL NO: _____ TEST STAND OPERATOR: _____ CDI: _____

1. OVERLOAD TEST: (MODELS 29267-A1, 3260024-0101, AND F2700-200C ONLY) 25 INH₂O (1.85 INHg) HOLD FOR 2 MINUTES. NO DAMAGE TO REGULATOR ALLOWED.
 - A. MODEL 29267-A1/3260024-0101 ALLOWABLE LEAKAGE 600CCM: _____
 - B. MODEL F2700-200C ALLOWABLE LEAKAGE 1750 CCM: _____
- 1A. BODY LEAKAGE TEST: (MODEL 900-002-025-05 ONLY) 10 INH₂O NO LEAKAGE ALLOWED: _____
2. DEMAND VALVE LEAKAGE TEST: 110 PSIG INLET PRESSURE. OUTLET PRESSURE NOT TO EXCEED 2.50 INH₂O IN 5 MINUTES _____
3. SAFETY PRESSURE TEST: READING MUST BE BETWEEN 0.50 AND 2.50 INH₂O.

ALTITUDE (FEET)	INLET PRESS (PSIG)	0 LPM FLOW (INH ₂ O)	READING	100 LPM FLOW (INH ₂ O)	READING
SEA LEVEL	50	0			
SEA LEVEL	90	0			
34,000	50	0			
34,000	90	0			

4. PRESSURE BREATHING TEST:

ALTITUDE (FEET)	INLET PRESS (PSIG)	0 LPM FLOW (INH ₂ O)	READING	100 LPM FLOW (INH ₂ O)	READING	OUTLET PRESSURE (INH ₂ O)	
						MIN	MAX
35,000	90	0				0.50	3.5
43,000	90	0				9.2	12.5
50,000	90	0				14.0	18.0
5. REGULATOR OXYGEN PURGE: APPLY 90 PSIG, AVIATORS BREATHING OXYGEN AND FLOW 1 TO 3 MINUTES.

Figure 12-2.—Regulator Performance Test Sheet.

WARNING

BECAUSE OF POSSIBLE VACUUM PUMP EXPLOSION, ONLY WATER-PUMPED NITROGEN, TYPE 1, CLASS 1, GRADE B, (FED. SPEC BB-N-411) WILL BE USED IN TESTING OXYGEN REGULATORS. USE ONLY NITROGEN FROM GRAY CYLINDERS MARKED NITROGEN OIL FREE IN WHITE LETTERS. TWO 3-INCH WIDE BLACK BANDS MARK THE TOPS OF THESE CYLINDERS. OXYGEN TEST STANDS CONTAIN A MERCURY MANOMETER. MERCURY IS A TOXIC METAL. AVOID BREATHING MERCURY VAPORS. AVOID CONTACT WITH SKIN OR CLOTHING.

OVERLOAD TEST. To perform the overload test, proceed as follows:

1. Cap the regulator inlet and attach the regulator outlet to the short hose attached to piezometer (26) in the chamber. Ensure all test stand valves are in the secured position, then open the N₂ supply cylinder valve.

NOTE: Ensure the regulator outlet and piezometer (26) are one inch apart.

2. Using the hose supplied with the test stand, connect LOW PRESS connection (19) to REF. TAP connection (21) in the chamber.

3. Ensure the FLOW SELECTOR valve (M) is in the REGULATOR position.

4. Adjust LOW PRESS. REGULATOR (N) so that regulated LOW PRESS. gauge (11) indicates 70 psig.

NOTE: When the in-system leakage rotameters are used, an inlet pressure of 70 psig will normally be used, as this is the pressure used to calibrate the rotameters.

5. Place PRESS. SELECTOR valve (D) in the Hg position.

6. Slowly open LEAKAGE CONTROL valve (E) until 1.85 inches in Hg is indicated on Hg manometer (5). Maintain 1.85 inches of Hg for 2 minutes. If no leakage is indicated on HIGH RANGE LEAKAGE rotameter (B), turn LEAKAGE SELECTOR valve (F) to the LOW RANGE position and check for leakage on the LOW RANGE LEAKAGE rotameter (7). The maximum allowable leakage will be no more than the allowable leakage for each model shown on the performance test sheet. If the leakage is excessive,

dispose of the regulator in accordance with your local directives.

NOTE: A body leakage test is done on the model 900-002-025-05 regulator only. Refer to the NAVAIR 13-1-6.4, DEMAND VALVE LEAKAGE TEST.

WARNING

NEVER BLOCK THE OUTLET OF THE MINIATURE REGULATOR WHILE A PRESSURE IS APPLIED TO THE INLET. THIS WILL SERIOUSLY DAMAGE THE REGULATOR.

NOTE: If a high reading is encountered during this test, make sure the pressure breathing aneroid is not screwed into the regulator housing too far before disposing of the regulator. Turn the pressure breathing aneroid counterclockwise out of the regulator housing and then recheck the readings.

7. Disconnect the hose from LOW PRESS connection (19) and REF TAP connection (21) in the altitude chamber.

8. Uncap the regulator inlet and connect the regulator inlet to N₂ input connection (18) in the altitude chamber.

9. Ensure PRESS SELECTOR valve (D) is in the Hg position.

10. Turn on the vacuum pump.

11. Turn INLET PRESS on/off valve (L) to ON slowly.

12. Using LOW PRESS REGULATOR (N), apply 110 psig to the regulator inlet. The pressure will be indicated on N₂ INPUT PRESS gauge (27).

13. Open OUTPUT valve (C) to draw a flow through the regulator, then close valve (c).

14. Place PRESS SELECTOR valve (D) in H₂O position. Observe the PRESS/SUCTION manometer (4) for 5 minutes. The pressure must not exceed 2.5 inches of H₂O. After the 5 minute period, read manometer (4) and enter the reading on the performance test stand. If the leakage is excessive, dispose of the regulator.

15. Leave the positions of all controls and connections unchanged.

SAFETY PRESSURE TEST. To perform the safety pressure test, proceed as follows:

1. Adjust LOW PRESSURE REGULATOR (N) to 50 psig as indicated on N₂ INPUT PRESS gauge (27).

CAUTION

OPEN FLUTTER DAMPENER VALVE (J) 1/4 TURN. IF THE REGULATOR CAUSES THE FLUID IN PRESS/SUCTION MANOMETER (4) TO FLUTTER, OPEN FLUTTER DAMPENER VALVE (J) SLOWLY UNTIL THE FLUTTER IS ELIMINATED. IF AT ALTITUDE DESCEND TO SEA LEVEL PRIOR TO OPENING VALVE (J) AS THE PRESS/SUCTION MANOMETER CAN BE EASILY OVERLOOKED. WHEN ASCENDING TO ALTITUDE MAINTAIN AN OUTPUT FLOW OF 6.0 INCHES OF H₂O.

NOTE: When increasing flows the inlet pressure must be adjusted to maintain the correct inlet pressure on N₂ INPUT PRESS gauge (27).

2. With OUTPUT valve (C) closed, read PRESS/SUCTION manometer (4) and enter the reading in the appropriate block on the performance test sheet.

3. Adjust OUTPUT valve (C) to the equivalent of 100 lpm as indicated on the OUTPUT manometer (1). Read the safety pressure as indicated on the PRESS/SUCTION manometer (4) and enter this figure on the performance test sheet. The safety pressure must not be less than 0.50 nor greater than 2.5 inches in H₂O for all flows.

4. Adjust low-pressure regulator (N) to 90 psig as indicated on the N₂ INPUT PRESS gauge (27).

5. Repeat steps 2 and 3.

6. Close the altitude chamber door.

7. Ensure that REF PRESS SELECTOR valve (O) is in the ALT. POSITION.

NOTE: A 6.0-inch flow in H₂O must be drawn with OUTPUT valve (C). Open FLUTTER DAMPENER valve (J) 1/4 turn.

8. If the altitude chamber is inadvertently taken above the test altitudes, open chamber bleed valve (K) slowly and descend to the desired altitudes. Close valve (K).

9. Using VACUUM CONTROL valve (B), ascend to 34,000 feet as indicated on LOW RANGE ALTM. (13).

10. Repeat steps 1 through 5.

NOTE: If low safety pressure is encountered, dispose of the regulator. If high safety pressure is encountered at 34,000 feet, before disposing of the regulator ensure that the pressure breathing has not cut-in before 35,000 feet giving a false indication of high safety pressure.

11. Leave the position of all controls and connections unchanged, and continue to the pressure breathing test.

PRESSURE BREATHING TEST. To perform the pressure breathing test, proceed as follows:

NOTE: If problems are encountered during this test, refer to pressure breathing troubleshooting table 12-2 for adjustment of the pressure breathing aneroid.

1. Open OUTPUT valve (C) and draw a flow of 6.0 inches in H₂O through the regulator. Using VACUUM CONTROL valve (B) ascend to 35,000 feet as indicated on the LOW RANGE ALTM. (13).

Table 12-2.—Troubleshooting (Pressure Breathing Test)

Trouble	Probable Cause	Remedy
Pressure breathing cuts in above 35,000 feet.	Aneroid assembly too far into regulator housing.	Adjust aneroid assembly counterclockwise.
Pressure breathing cuts in below 35,000 feet.	Aneroid assembly too far out of regulator housing.	Adjust aneroid assembly clockwise.
Pressure breathing cannot be adjusted within limits.	Defective or damaged aneroid assembly.	Replace regulator with RFI component.

2. Using LOW PRESS. REGULATOR (N), adjust the inlet pressure to 90 psig. Close OUTPUT valve (C).

3. Read the PRESS/SUCTION manometer (4). The reading must be between 0.50 and 3.5 in H₂O. Enter this reading in the appropriate block of the performance test sheet.

4. Adjust OUTPUT valve (C) to a flow of 100 lpm and read the PRESS/SUCTION manometer (4). The reading must also be between 0.50 and 3.5 in H₂O. Enter this reading on the test sheet also.

5. Increase the altitude to 43,000 feet, as shown on the HIGH RANGE ALTM. (12), and repeat steps 1 through 3. The readings on PRESS/SUCTION manometer (4) must be between 9.2 and 12.5 in H₂O.

6. Increase the altitude to 50,000 feet. The readings must be between 14.0 and 18.0 in H₂O at this altitude.

7. After the completion of this test, leave OUTPUT valve (C) slightly open, and open CHAMBER BLEED valve (K) and return to sea level.

8. Open the chamber door and close valve (C). Turn off the vacuum pump.

9. Turn ON/OFF valve (L) to OFF, and remove the regulator from the test stand.

10. Close the N₂ supply cylinder and, using LOW PRESS. REGULATOR (N) and SYSTEM BLEED valve (S), relieve all the pressure in the test stand. Secure all the test stand valves.

11. If the aneroid should need adjusting, loosen the aneroid lock screw using a .035 Allen wrench and adjust the aneroid assembly using retaining pliers in accordance with the pressure breathing test troubleshooting table 12-2.

NOTE: Remember we are discussing the model 29267-A1 regulator only. For other models of the CRU-79/P miniature regulator, you must refer to the NAVAIR 13-1-6.4 manual.

After the completion of all the tests, you must purge the regulator with aviator's breathing oxygen for 1 to 3 minutes at 90 psig to the regulator inlet.

WARNING

NEVER BLOCK THE OUTLET OF THE MINIATURE REGULATOR WHILE PRESSURE IS APPLIED TO THE INLET. THIS WILL SERIOUSLY DAMAGE THE REGULATOR.

After completion of the oxygen purge, place the regulator in a plastic bag for storage.

AIRCRAFT PANEL-MOUNTED REGULATORS

The MD-1, CRU-52/A, CRU-54/A, CRU-55/A, CRU-57/A, MD2, and CRU-72/A shown in figures 12-3 and 12-4 are panel-mounted, automatic, positive pressure diluter demand-type regulators, and they are used in conjunction with the pressure breathing type oxygen mask. The regulators provide 100-percent oxygen, or an air/oxygen mixture at the correct ratio, depending

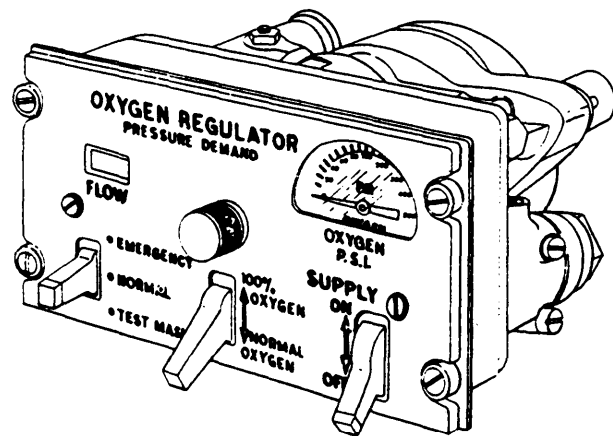

Figure 12-3.—Aircraft panel mounted oxygen regulator, MD-1 (low pressure).

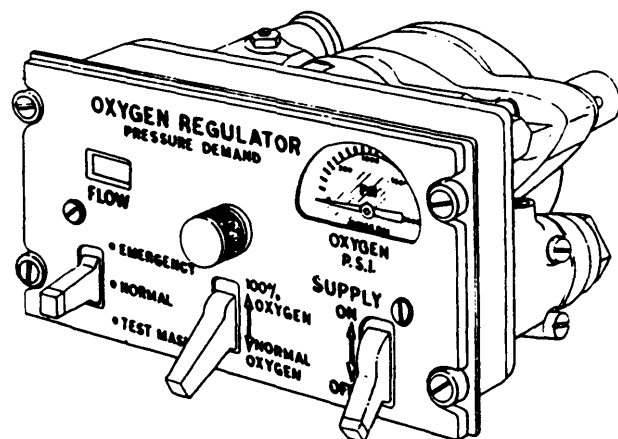

Figure 12-4.—Aircraft panel mounted oxygen regulator, MD-2 (high pressure).

on altitude, to the user on demand. The regulators incorporate an emergency pressure control lever. During normal operation, the lever is set in the NORMAL position. A TEST MASK position is provided to test the oxygen supply function of the regulators at low altitudes and at ground level. When in the EMERGENCY position, the regulators deliver 100-percent oxygen to the user at a positive pressure. The EMERGENCY position is used when normal oxygen is suspected of being inadequate.

The regulators are supplied in two basic configurations: low pressure (50 to 500 psig operating pressure range), and high pressure (50 to 2000 psig operating range). Refer to table 12-3 for applicable models and part numbers.

MAINTENANCE

When assigned to an AIMD or a depot-level maintenance activity, you may be involved in making repairs to these regulators. When the cost of repair is more than approximately 75 percent of the cost of the regulator, it is considered beyond economical repair.

TURNAROUND/PREFLIGHT/ POSTFLIGHT/TRANSFER INSPECTIONS

The turn around/preflight/postflight/transfer inspections consist of a visual type inspection performed in conjunction with the aircraft inspection requirements for the aircraft in which

Table 12-3.-Leading Particulars

CHARACTERISTICS	
MD-1	14950-7B 50 to 500 psi
CRU-52/A	14950-26A 50 to 500 psi
CRU-54/B	14950-27A 50 to 500 psi
CRU-55/A	14950-28A 50 to 500 psi
CRU-57/A	14950-30A 50 to 500 psi
MD-2	14800-8B 50 to 2000 psi
CRU-72/A	14800-8C 50 to 2000 psi
Voltage 28 Vdc	
Mounting Panel	
Operating Altitude Range:	
Normal Breathing	Up to 30,000 ft
Pressure Breathing Starts	At 30,000 ft
Air-Oxygen Mixture	Up to 32,000 ft
100% Oxygen Delivery Starts	At 32,000 ft
Visual Indicators Pressure Gauge and Flow Indicator on Front Panel	
Regulator Controls:	
Diluter Lever	Selects NORMAL or 100% OXYGEN
Supply Lever	Opens and closes oxygen supply
Emergency Lever	For emergency, and ground test of mask
Overall Dimensions:	
Length	4 7/32 in
Width	5 3/4 in
Height	3 in
Weight	2.85 lb

the regulators preinstalled. Refer to table 12-4 for assistance in troubleshooting. To perform the inspection, visually inspect the following:

1. Electrical performance of panel light.
2. Legibility of all markings.
3. Plastic lighting plate for cracks and discoloration.
4. Low, or improper reading on regulator pressure gauge.
5. Emergency pressure control lever in NORMAL position.
6. Diluter control lever in 100-percent OXYGEN position.
7. Supply control lever in OFF position.
8. Regulator and surrounding area for freedom from dirt and hydrocarbons.
9. Delivery hose and connector for cuts, graying, kinking, hydrocarbons and general condition.

If discrepancies are found or suspected, notify maintenance control.

If a regulator does not pass your inspection and the defect cannot be repaired in the aircraft, remove it and put in a ready for issue (RFI) regulator. Forward the defective regulator to an aircraft intermediate maintenance activity that can fix it.

ACCEPTANCE/SPECIAL/DAILY INSPECTIONS

The acceptance/special/daily inspections consist of a visual inspection followed by a functional test. These inspections and tests are performed in conjunction with the aircraft inspection requirements for the aircraft in which the regulators are installed. These inspections are performed at the organizational level by AMEs. However, you should know what they are supposed to inspect. Refer to table 12-4 for assistance in troubleshooting. To perform the inspection, visually inspect the regulators as you did in the preflight inspection.

Table 12-4. Troubleshooting (Daily, Preflight, Special, Turnaround, Transfer and Acceptance Inspections)

Trouble	Probable Cause	Remedy
Oxygen cylinder pressure gage fails to indicate proper pressure	Defective gage	Replace regulator.
	Blocked or leaking supply line	Replace or clean supply line to regulator.
	Low cylinder pressure	Refill.
	Defective manifold inlet assembly	Replace regulator.
Oxygen not available at mask with proper pressure source to regulator and other than emergency setting on regulator	Regulator controls improperly positioned	Correct position of controls.
	Hose to mask is kinked	Straighten hose and reposition outlet.
	Regulator not functioning properly	Replace regulator.
Oxygen not available at mask with proper pressure source to regulator and regulator control set at EMERGENCY	Kink or other malfunction between hose and mask	Replace or readjust equipment as necessary.
	Faulty linkage from emergency pressure control level	Replace regulator.
Oxygen available at mask but flow is not indicated	Defective blinker assembly	Replace regulator.
Gage pressure drops when regulator is not in use	Loose or leaking connections	Tighten or replace connections as necessary.
	Defective manifold inlet assembly	Replace regulator.
Panel light fails to light	Burned out lamp	Replace lamp.
	Faulty light assembly	Replace Regulator.
	Faulty electrical hookup to power source	Repair electrical hookup.

To perform the functional test proceed as follows:

1. Place the supply valve control lever in the ON position.
2. Place the diluter control lever in NORMAL OXYGEN position.
3. Using an oxygen mask and hose assembly, connect the hose to the quick disconnect. While at ground level, the regulator will not supply oxygen from the supply system to the mask. The emergency pressure control lever must be used in order to check out the oxygen supply function of the regulator at low altitudes. (The emergency lever is spring loaded at the NORMAL position, and will return to NORMAL when released.) Place the mask to your face with the regulator in test mask position and inhale. Proper regulator operation will be indicated by the flow indicator assembly showing white during inhalation and black during exhalation.
4. Hold the emergency pressure control lever in the TEST MASK position and observe the flow indicator. The flow indicator should be white, indicating a flow through the regulator.

Upon completion of the functional test, secure the regulator as follows:

1. Disconnect the mask from the supply hose.
2. Ensure that the emergency pressure control lever returns to its NORMAL position.
3. Place the diluter control lever in the 100-percent position.
4. Place the supply valve control lever in the OFF position.

If any discrepancies are found or suspected, notify maintenance control. If repairs cannot be made in the aircraft, replace the regulator and forward the defective regulator to AIMD for repairs.

CALENDAR/PHASED/SDLM INSPECTIONS

You must remove the regulator to give it a calendar, phased or SDLM (standard depot-level maintenance) inspection. See applicable Planned Maintenance System (PMS) publications for specified intervals. In no case can the interval exceed 231 days. Upon removing it from the aircraft, the regulators are visually inspected and sent to AIMD for bench testing.

Aircraft panel-mounted regulators that fail the bench test must be repaired. Source, Maintenance and Recoverability (SM&R) codes define repairability of components and lowest level of maintenance authorized.

Service Life

Oxygen regulators remain in service for as long as they function correctly and do not require excessive repair (exceeds 75-percent of original cost of regulator). All silicone rubber parts are replaced whenever a regulator is disassembled for repair.

Bench Test

Bench tests are performed on aircraft panel-mounted oxygen regulators prior to being placed in service, and during the phase/calendar or SDLM inspection cycle of the aircraft in which installed. See applicable PMS publications for specific intervals. The inspection interval must not exceed 231 days. The regulators are also subjected to a bench test if malfunction is suspected, and after repair or replacement of damaged parts.

Bench tests are performed using Oxygen System Components Test Stand, Model 1172AS100, in accordance with NAVAIR 13-1-6.4. Because of the complexity of the 1172AS100 test stand, it is essential that the operator become thoroughly familiar with the test stand prior to performing bench tests.

NOTE: Nitrogen supply cylinders used in testing oxygen components are 80 cubic feet and contain a maximum pressure of 2000 ± 200 psig. For tests requiring pressures of 1800 psig, use highest available pressure, but in no case can this pressure be less than 500 psig.

Inward Leakage Test

By applying 9.0 inches (H₂O) of suction to the regulator outlet, you are testing the regulator to be leaktight. If a leak is present, it could effect other tests covered in the chapter. It could also prevent the aircrewman from receiving 100-percent oxygen by allowing ambient air to enter the regulator.

To perform the inward leakage test, proceed as follows:

1. Ensure that all test stand valves are closed, then open N₂ supply cylinder valve.

2. Place the regulator supply control valve lever in the OFF position, and the diluter control lever in the 100-percent OXYGEN position.

3. Ensure that the regulator emergency pressure control lever is in the NORMAL position.

4. Mount the adapter supplied with the test stand (NAVAIR Drawing No. 1172AS136), and connect the regulator outlet to the N₂INPUT connection in the altitude chamber.

5. Connect a line from the LOW PRESS connection to REFERENCE TAP in the altitude chamber. Plug the rubber hose attached to the piezometer by using the piezometer plug supplied with the test stand. Ensure that the LOW PRESSURE REGULATOR is not loaded. This will prevent N₂ supply cylinder pressure from passing onto the INLET PRESSURE ON/OFF valve which could damage the test item or injure the test stand operator.

6. Turn the INLET PRESSURE ON/OFF valve to the ON position. The vacuum vent must be opened one to two turns when you operate the vacuum pump. Turn the vacuum pump on.

7. Turn the PRESSURE SELECTOR valve to the H₂O position, and fully open the LEAKAGE CONTROL valve.

8. Ensure that the LEAKAGE SELECTOR valve is in the HIGH RANGE position.

9. The leakage rotameter is calibrated with an applied pressure of 70 psig. The inward leakage test requires that a suction of 9.0 in H₂O be applied to the regulator outlet and the rotameter. This pressure difference (9.0 in H₂O vice 70 psig) creates a wide variance between actual leakage and indicated leakage. The maximum allowable leakage for the inward leakage test is 200 cubic centimeters per minute, and is displayed as 740 ccm on the high range leakage rotameter.

NOTE: Because of labeling on gauges, the abbreviation ccm is used in this text. Since the cubic centimeter has been replaced by the milliliter, this abbreviation should be ml/min instead of ccm. The proper abbreviation may appear on later equipment and newer technical manuals.

Slowly open the OUTPUT valve until 9 inches of H₂O suction is indicated on the PRESSURE/SUCTION manometer. Any leakage will be displayed on the HIGH RANGE LEAKAGE rotameter. The maximum allowable indicated leakage reading is 740 ccm (actual 200 ccm). Record the indicated leakage on the Performance Test Sheet.

10. Close the OUTPUT valve and the LEAKAGE CONTROL valve. Turn the vacuum pump OFF. Turn the INLET PRESSURE ON/OFF valve to the OFF position.

Table 12-5A.—Troubleshooting (Inward Leakage Test)

Trouble	Probable Cause	Remedy
Diluter plate control housing and check valve assembly leaking	Damaged diluter valve assembly	Replace diluter valve assembly
	Diluter housing gasket leaking	Tighten screws, or replace diluter housing gasket
	Preformed packing leaking	Replace preformed packing
	Diluter plate and seat assembly damaged	Replace diluter plate and seat assembly
	Manual diluter valve lever bent or binding	Replace manual diluter valve lever
Diluter valve control lever leaking	Diluter valve control lever not adjusted properly	Adjust diluter valve control lever
Leakage from regulator outlet	Preformed packing leaking	Replace preformed packing
	Loose screws	Tighten screws
Leakage at relief valve	Leakage past relief valve, or relief valve seat excessive	Replace relief valve and seat

11. Disconnect the line from the LOW PRESSURE connection and REF. TAP in the altitude chamber. Disconnect the regulator outlet from N₂ INPUT connection, and remove the plug from the piezometer.

12. If excessive leakage is indicated, locate the probable cause by using troubleshooting chart, table 12-5A.

Outlet Leakage Test

To perform an outlet leakage test, proceed as follows:

1. Place the regulator supply valve control lever in the ON position.

2. Ensure that the diluter control lever is in the 100-percent OXYGEN position.

3. Place the emergency pressure control lever in the NORMAL position.

4. Mount the regulator on a horizontal plane in the test chamber. Connect the regulator inlet to the N₂ INPUT connection (18) inside the altitude chamber.

5. By using the LOW PRESSURE REGULATOR, apply 150 psig to the regulator inlet.

6. Slowly turn the INLET PRESSURE ON/OFF valve to ON.

7. Activate the emergency pressure control lever to allow a flow through the regulator, then return the lever to its NORMAL position.

8. Draw a film of leak detection compound (MIL-L-25567) across the regulator outlet. The film should not advance more than 1/2 inch in 10 seconds. If the film advance is more than allowable, repeat the test three or four times. (Distention could be caused by difference in temperature between inside and outside of regulator.)

9. If the film advance continues to be more than allowed, locate the probable cause by using the troubleshooting chart, table 12-5B.

10. Relieve pressure on the regulator by backing out on the LOW PRESSURE REGULATOR.

OXYGEN SUPPLY VALVE LEAKAGE TEST.—

If the supply pressure could not be shut off, until a demand was placed on it, a pressure buildup could be created. It could damage the regulator hose or mask and possibly injure the crewmen. To perform the oxygen supply valve leakage test with the regulator still mounted in the chamber, proceed as follows:

1. Place the regulator oxygen supply valve lever in the OFF position.

Table 12-5B.—Troubleshooting (Outlet Leakage Test)

Trouble	Probable Cause	Remedy
Demand valve assembly leaking	Damaged demand valve seat	Replace seat
	Damaged demand valve assembly	Replace assembly
	Damaged preformed packings	Replace packings
Emergency pressure control assembly loading	Emergency pressure lever stem out of adjustment	Readjust elastic nut so that emergency pressure control assembly is not loading diaphragm
Pressure breathing aneroid assembly	Expanded aneroid	Replace aneroid
	Improperly adjusted aneroid	Add or delete shims
First stage reduction pressure	Pressure too high	Adjust to 32 to 35 psi
First stage regulator valve and lever assembly	Lever pivot screw improperly adjusted	Readjust until approx. 2 or 3 threads show
First stage relief valve	Damaged relief valve seat	Replace seat
	Pressure too low	Adjust to 55 to 60 psig
	Weak relief valve spring	Replace spring
	Damaged preformed packing	Replace packing

2. Place the emergency pressure control lever in the EMERGENCY position.

3. Using HIGH PRESSURE REGULATOR, apply pressure specified in table 12-6 to the regulator inlet. Slowly turn the INLET PRESSURE ON/OFF valve to ON.

4. Draw a film of leak detection compound (MIL-L-25567) across the regulator outlet fitting. As in the last test, see if there is any distention of the film.

5. There is no allowable leakage. If leakage is noted, locate probable cause using troubleshooting chart, table 12-7.

6. Place the emergency control lever in the NORMAL position.

OVERALL LEAKAGE TEST.— Test, by trapping pressure in the regulator, for any leakage anywhere on or in the regulator. Perform the overall leakage test first with diluter lever in its 100-percent OXYGEN position, and then repeat it with the lever in the NORMAL OXYGEN position.

1. Place regulator oxygen supply valve lever in the ON position, and emergency pressure control lever in the NORMAL position.

2. By using test stand HIGH PRESSURE REGULATOR, apply pressure specified in table 12-8 to regulator inlet.

3. Turn INLET PRESSURE ON/OFF valve to OFF. Leave the regulator oxygen supply valve lever in the ON position.

4. Leakage will be indicated on the regulator pressure gauge. Allowable leakage should not exceed 60 psig over a 2-minute period. Repeat the test with the diluter lever turned to NORMAL OXYGEN.

Table 12-6.—Inlet Pressure (Oxygen Supply Valve Leakage Test)

TYPE	INLET PRESSURE (PSIG)
MD-1	500
MD-2	1800
CRU-52/A	500
CRU-54/A	500
CRU-55/A	500
CRU-57/A	500
CRU-72/A	1800

5. If allowable leakage is exceeded, locate the probable cause by using the troubleshooting chart, table 12-9.

6. Turn the HIGH PRESSURE REGULATOR to VENT.

7. Bleed the regulator by placing the emergency pressure control lever in the EMERGENCY position. Return the lever to NORMAL.

8. Bleed the test stand using the SYSTEM BLEED valve.

REGULATOR PRESSURE GAUGE SCALE AND ERROR TEST.— This test ensures that the pressure gauge is operating properly and within tolerance. To perform the regulator pressure gauge scale and error test, proceed as follows:

1. Turn the INLET PRESSURE ON/OFF valve to ON. The LOW PRESSURE REGULATOR can only be used when applying pressures below the gauge guard setting (165 to 175 psig) to an item under test. For pressures above the gauge guard setting, the HIGH PRESSURE REGULATOR must be used.

2. Using LOW PRESSURE REGULATOR (N), slowly increase the pressure to each test pressure in 100 psig increments and below, as specified in table 12-6. Record the regulator pressure gauge readings twice, once before and once after tapping regulator pressure gauge.

3. Check the tolerance by comparing the regulator pressure gauge reading with the test stand INPUT PRESSURE gauge.

4. Back out on the LOW PRESSURE REGULATOR.

5. Continue the test for 500 psig pressure by using the HIGH PRESSURE REGULATOR.

6. Turn the HIGH PRESSURE REGULATOR to VENT.

7. Bleed the test standby using the SYSTEM BLEED valve. Bleed the regulator using the emergency pressure control lever.

OUTWARD LEAKAGE TEST.— In performing this test, the relief valve is not covered. The allowable leakage through this valve at 17.0 inches H₂O is included in the maximum allowable leakage of 120 ccm.

NOTE: This text uses the abbreviations **lpm** for liters per minute. Newer equipment and technical manuals may use the correct abbreviation, which is **L/min**.

Table 12-7.-Troubleshooting (Oxygen Supply Valve Leakage Test)

Trouble	Probable Cause	Remedy
Loading of manifold inlet assembly	Supply valve control stem out of adjustment	Readjust supply valve control stem
Leaking manifold inlet assembly	Damaged ball	Replace ball
	Damaged supply valve seat	Replace seat
	Damaged supply valve seat retainer	Replace retainer
	Damaged preformed packings	Replace damaged packing(s)

Table 12-8.-Inlet Pressure (Overall Leakage Test)

TYPE	INLET PRESSURE (PSIG)
MD-1	500
MD-2	1800
CRU-52/A	500
CRU-54/A	500
CRU-55/A	500
CRU-57/A	500
CRU-72/A	1800

With the regulator still mounted in the chamber, proceed as follows:

1. Place the regulator supply valve control lever in the OFF position, and the diluter control lever in the NORMAL OXYGEN position.
2. Connect the regulator outlet to the piezometer in the altitude chamber.
3. Connect a line from the LOW PRESSURE connection to the REFERENCE TAP inside the chamber.
4. Turn the test stand INLET PRESSURE ON/OFF valve to the OFF position.

Table 12-9.-Troubleshooting (Overall Leakage Test)

Trouble	Probable Cause	Remedy
Manifold inlet assembly leaking	Loose manifold inlet adapter	Tighten or replace manifold inlet adapter
	Damaged preformed packings	Replace damaged packing(s)
	Loose manifold inlet assembly screws	Tighten screws
Pressure gauge leaking	Oxygen cylinder pressure gauge assembly	Replace pressure gauge
	Damaged preformed packing	Replace packing
	Loose screws	Tighten screws
First stage reduction chamber leaking	Loose screws on first stage cover plate	Tighten screws
	Damaged first stage gasket	Replace gasket
	Damaged first stage bellows gasket	Replace gasket
Pressure breather assembly leaking	Loose screws	Tighten screws
	Damaged preformed packing	Replace packing
	Damaged pressure breather valve assembly	Replace assembly
Emergency pressure control assembly loading	Emergency pressure control lever and center assembly loading diaphragm and plate assembly	Adjust emergency pressure control stem by tightening or loosening elastic nut
	Wrong size emergency pressure spring guide	Replace with shorter guide

5. Adjust the LOW PRESSURE REGULATOR until 70 psig is indicated on the REGULATED LOW PRESSURE gauge.

6. Turn the PRESSURE SELECTOR valve to the H₂O position, and slowly open the LEAKAGE CONTROL valve until 17.0 inches of H₂O is indicated on PRESSURE/SUCTION manometer. By adjusting the LEAKAGE CONTROL, you maintain 17.0 inches of H₂O indication throughout this test.

7. If no leakage is indicated on the HIGH RANGE LEAKAGE rotameter, turn the LEAKAGE SELECTOR valve to the low range position, and check for an indication of leakage on the low RANGE LEAKAGE rotameter. Allowable leakage is 0.12 lpm (120 ccm).

8. Switch the LEAKAGE SELECTOR valve to HIGH position, and close the LEAKAGE CONTROL valve.

9. Repeat steps 6, 7, and 8 with the diluter control lever in the 100-percent OXYGEN position.

10. If leakage is excessive, locate its probable cause using troubleshooting chart, table 12-10.

SECOND STAGE RELIEF VALVE TEST.—

To perform the second stage relief valve test, proceed as follows:

1. Turn the PRESSURE SELECTOR valve to the Hg position, and place the FLOW SELECTOR valve in the CONTROLLER position.

2. Ensure the diluter control lever is in the 100-percent OXYGEN position.

3. Using the VENT PRESSURE valve, slowly apply 3 inches of mercury to the regulator outlet. The regulator relief valve should be venting at least 45 lpm, as indicated on the vent flow manometer.

4. Close the VENT PRESSURE valve and bleed the pressure down to 0 in Hq using VENT AMBIENT valve. Close the valve.

Table 12-10.—Troubleshooting (Outward Leakage Test)

Trouble	Probable Cause	Remedy
Diluter plate control housing and check valve assembly leaking	Damaged diluter plate control housing and check valve preformed packings	Replace packings
	Damaged air valve seat	Replace diluter control housing
	Damaged check valve disc	Replace disc
	Improperly adjusted diluter plate control housing and check valve assembly	Adjust spring and screw adapter assembly
	Loose screws	Tighten screws
Regulator outlet leaking	Damaged preformed packings	Replace packings
	Damaged or loose outlet	Tighten, or replace outlet
	Excessive inward leakage	
Flow indicator leaking	Damaged blinker diaphragm assembly	Replace blinker diaphragm assembly
	Damaged blinker tubing and base plate	Replace blinker tubing and base plate
	Loose screws	Tighten screws
Second stage relief valve leaking	Out of adjustment	Adjust spring retainer
	Weak second stage relief valve spring	Replace spring
	Loose housing screws	Tighten screws
	Damaged gasket	Replace gasket
	Damaged preformed packing	Replace packing
Outer diaphragm, diaphragm and plate assembly leaking	Loose screws	Tighten screws
	Damaged outer diaphragm	Replace outer diaphragm
	Damaged diaphragm and plate assembly	Replace diaphragm and plate assembly

5. Turn the FLOW SELECTOR valve to the REGULATOR position and close the VENT AMBIENT valve.

6. Slowly move the PRESSURE SELECTOR valve to the H₂O position.

7. Turn the LEAKAGE SELECTOR valve to the LOW position.

8. Open the LEAKAGE CONTROL valve. Apply and maintain 17.0 inches of H₂O to regulator outlet. Maximum allowable leakage is 0.12 lpm (120 ccm).

9. Close the LEAKAGE CONTROL valve.

10. Back out on the LOW PRESSURE REGULATOR and bleed the pressure with the SYSTEM BLEED valve.

11. Turn the LEAKAGE SELECTOR valve to the HIGH RANGE position.

12. If excessive leakage is found, locate the probable cause using the troubleshooting chart, table 12-10. If the relief valve does not vent, locate the probable cause by using the troubleshooting chart, table 12-11.

FLOW SUCTION TEST.— This test determines how much suction will be required by the user to achieve or receive a given amount of oxygen or air/oxygen mixture through the regulator. To perform the flow suction test, proceed as follows:

1. Disconnect the hose from the LOW PRESSURE connection and REFERENCE TAP connection inside the altitude chamber.

2. Turn vacuum pump ON.

3. Ensure that the PRESSURE SELECTOR Valve is in the H₂O position.

4. Ensure that the regulator diluter control lever is in the 100-percent OXYGEN position.

5. Ensure that the INLET PRESSURE ON/OFF valve is ON.

6. Ensure that the regulator supply valve control lever is in the ON position.

7. By using the LOW PRESSURE REGULATOR, set the inlet pressure at each inlet pressure specified on the Performance Test Sheet.

8. By using the OUTPUT valve, set flows specified in the Performance Test Sheet on the OUTPUT manometer. Readings must be recorded with the regulator diluter control lever in both NORMAL and 100-percent OXYGEN positions for each outlet flow specified on the Performance Test Sheet. Suction values will be displayed on PRESSURE/SUCTION manometer. With no suction on the regulator (OUTPUT valve closed), maximum flow through regulator should not exceed 0.01 lpm. This will cause a slight rise in the PRESSURE/SUCTION manometer reading. Record readings on the Performance Test Sheet.

9. Close OUTPUT valve.

10. If the regulator fails the flow suction test, locate the probable cause by using the troubleshooting chart in table 12-12.

Table 12-11.—Troubleshooting (Second Stage Relief Valve Test)

Trouble	Probable Cause	Remedy
Second stage relief valve does not vent 45 lpm	Out of adjustment	Adjust spring retainer
	Second stage relief valve spring too strong	Replace spring

Table 12-12.—Troubleshooting (Flow Suction Test)

Trouble	Probable Cause	Remedy
First stage reduction chamber out of adjustment	Low first stage pressure	Reset to 32 to 35 psig
Demand valve lever assembly	Vane mounting pin	Replace mounting pin
	Strong demand valve lever spring	Replace demand valve lever spring
	Demand valve lever bent, or improperly adjusted	Replace, or adjust
Manifold inlet assembly Venturi assembly	Clogged inlet filter	Replace inlet filter
	Strong injector spring	Replace injector spring

OXYGEN RATIO TEST.— This test determines the amount of oxygen mixed with ambient air up to 32,000 feet where 100-percent oxygen will be automatically delivered to the user. To perform the oxygen ratio test, proceed as follows:

1. Ensure that the regulator supply valve control lever is in the ON position, and the diluter control lever is in the NORMAL OXYGEN position.

2. By using the LOW PRESSURE REGULATOR, apply 150 psig to the regulator inlet. Slowly open the VACUUM CONTROL valve (B₁) and observe the PRESSURE/SUCTION manometer. If a rapid increase in pressure is indicated, close down on VACUUM CONTROL valve (B₁) until pressure stabilizes. This rapid increase of pressure shown on PRESSURE/SUCTION manometer is caused by too fast a rate of climb in the altitude chamber. Maintain 3.0 inches of H₂O on the OUTPUT manometer with OUTPUT valve while "ascending to altitude."

3. Using VACUUM CONTROL valve (B₁), ascend to the first test altitude shown on the Performance Test Sheet.

4. Set the output flows specified in the Performance Test Sheet with OUTPUT valve, and stabilize altitude with INPUT valve.

5. Read all readings on the INPUT manometer, and record all readings on the Performance Test Sheet.

6. Continue the test for each specified altitude and output flow shown on the Performance Test Sheet.

7. Close OUTPUT valve and INPUT valve. Descend to 27,000 feet using CHAMBER BLEED valve.

8. If oxygen ratio test was satisfactory, proceed to make the safety pressure and pressure breathing test. If indicated input flows are not within limits, an aneroid closure test must be performed. The aneroid closure test is performed only if regulator fails the oxygen ratio test.

ANEROID CLOSURE TEST.— The aneroid closure test is performed only if the regulator fails the oxygen ratio test. To perform the aneroid closure test, proceed as follows:

1. Descend to 25,000 feet by using the CHAMBER BLEED valve.

2. Ensure that the inlet pressure is as specified on the Performance Test Sheet.

3. Setup a flow of 5.0 inches of H₂O on the OUTPUT FLOW manometer with OUTPUT valve.

4. The aneroid closes between 28,000 and 32,000 feet, as indicated by no further advance in altitude on the LOW RANGE altimeter.

5. Close the OUTPUT valve and descend to sea level by using the CHAMBER BLEED valve.

6. If the regulator fails aneroid closure test and/or oxygen ratio test, locate probable cause using troubleshooting chart, table 12-13.

SAFETY PRESSURE AND PRESSURE BREATHING TEST.— This test determines if 100-percent oxygen is being delivered to the user through the regulator between 30 and 50,000 feet.

Table 12-13.—Troubleshooting (Oxygen Ratio/Aneroid Closure Tests)

Trouble	Probable Cause	Remedy
Incorrect air/oxygen ratios for flows 40 lpm or less	Low air	Turn screw in spring and screw adapter assembly counterclockwise
	High air	Turn screw in spring and screw adapter assembly clockwise
Incorrect air/oxygen ratio for flows above 40 lmp	Low air	Install shorter shouldering screw
	High air	Install longer shouldering screw
Aneroid closes below 28,000 feet	Aneroid stem out of adjustment	Turn aneroid stem counterclockwise
Aneroid closes above 32,000 feet	Aneroid stem out of adjustment	Turn aneroid stem clockwise

To perform the safety pressure and pressure breathing test, proceed as follows:

1. By using the LOW PRESSURE REGULATOR, apply 150 psig to the regulator inlet. If chamber altitude is not at 30,000 feet, adjust the altitude by using VACUUM CONTROL valve (B₁) to increase or CHAMBER BLEED valve to decrease altitude.

2. Using the OUTPUT valve, draw flows of 0, 40, and 85 lpm through the regulator. Delivery pressure must be within limits shown on Regulator Performance Test Sheet. Maintain 3.0 inches of H₂O on output manometer with OUTPUT valve while ascending to altitude. The reading for 0 lpm must also be recorded at each test altitude.

3. Repeat step 2 for each altitude shown on the Performance Test Sheet.

4. Close the OUTPUT valve and descend to sea level by using CHAMBER BLEED valve.

5. If the safety pressure breathing flows are not within limits, locate the probable cause using troubleshooting chart, table 12-14.

BLINKER ASSEMBLY TEST.— This test ensures that the blinker operates correctly with a demand placed on the regulator. To perform the blinker assembly test, proceed as follows:

1. Ensure that diluter control lever is in the NORMAL OXYGEN position.

2. By using the LOW PRESSURE REGULATOR, apply 150 psig to the regulator inlet.

3. Using OUTPUT valve draw a 20 lpm through the regulator. The blinker must open fully.

4. Reduce output flow to 8 lpm and place the diluter control lever in the 100-percent OXYGEN position. The blinker must remain fully open.

5. Close OUTPUT valve. The blinker should close immediately.

6. Close the altitude chamber door. Ascend to altitude while maintaining 3.0 inches of H₂O on the OUTPUT manometer with the OUTPUT valve.

7. By using the VACUUM CONTROL valve (B₁) ascend in altitude until 17.0 inches of H₂O is indicated on the PRESSURE/SUCTION manometer.

8. Open OUTPUT valve and draw a flow of 12 lpm through the regulator. The blinker should be fully open. Close OUTPUT valve and the blinker should close immediately.

9. Descend to sea level using the CHAMBER BLEED valve.

10. Adjust or replace improperly functioning blinkers.

EMERGENCY PRESSURE TEST.— Determine how much pressure is supplied to the user on emergency pressure. To perform the emergency pressure test, proceed as follows:

1. Ensure the diluter control lever is in the NORMAL OXYGEN position.

2. By using the LOW PRESSURE REGULATOR, apply 150 psig to the inlet of the regulator.

3. Open the OUTPUT valve and draw a 10 lpm flow through the regulator.

Table 12-14.—Troubleshooting (Safety Pressure/Pressure Breathing Test)

Trouble	Probable Cause	Remedy
Low safety pressure/pressure breathing	Clogged inlet filter	Replace inlet filter
	Damaged outer diaphragm	Replace outer diaphragm
	Aneroid shims too thin	Replace with thicker shims
	Aneroid screw or locknut too short	Replace with longer screw or locknut
	Pressure breather valve sticking or bent	Replace pressure breather valve
High safety pressure	Aneroid shims too thick	Replace with thinner shims
	Pressure breather valve sticking in open position, or bent	Replace pressure breather valve
	Cocked aneroid	Replace aneroid

4. Place the emergency control lever in the EMERGENCY position. Pressure indicated on PRESSURE/SUCTION manometer should read 2.0 to 4.0 inches of H₂O.

5. Adjust the OUTPUT valve to draw 80 lpm through the regulator.

6. Place the diluter control lever in the 100-percent OXYGEN position. Pressure at outlet of regulator, as indicated on PRESSURE/SUCTION manometer, should be no less than 1.0 inches of H₂O.

7. Close the OUTPUT valve. With zero flow, outlet pressure should not exceed 5.5 inches of H₂O.

8. Adjust the output to 10 lpm. Hold the emergency pressure control lever in TEST MASK position. The output flow indicated on the PRESSURE/SUCTION manometer should be 6.0 to 16.0 inches of H₂O.

9. Close the OUTPUT valve. With zero flow, outlet pressure should not exceed 17.5 inches of H₂O. Release the emergency pressure control lever. If the regulator fails, adjust the emergency pressure control lever stem to obtain 3.0 to 4.0 inches of H₂O at 10 lpm first, then compensate for excessive pressure drop at 80 lpm flow with the elastic stop nut.

10. If the emergency pressure flows are not within tolerance, locate the probable cause by using the troubleshooting chart, table 12-15.

11. Close the N₂ supply cylinder valve, by using the LOW PRESSURE REGULATOR and SYSTEM BLEED valve, relieve all pressure in the test stand. Secure all test stand valves.

12. Test stand operator and CDI must sign the Performance Test Sheet. The original, or a

copy of the Performance Test Sheet is forwarded to the operational custodian of the regulator.

LIQUID OXYGEN CONVERTERS

The liquid oxygen converter assembly discussed in this chapter is a GCU-24/A, P/N 10C-0016-10 (fig. 12-5) manufactured by Essex Cryogenics, Inc. (FSCM 19062). Information concerning other types can be found in NAVAIR 13-1-6.4. The converter assembly is designed to store and convert liquid oxygen (LOX) into gaseous oxygen for the aircrewman during flight. Table 12-16 contains the leading particulars for the converter assembly.

Oxygen in its liquid state (approximately -297 °F or -182 °C) is stored in a spherical assembly consisting of inner and outer shells separated by an annular space. The annular space is evacuated to create a vacuum. This prevents the transmittal of heat through the annular space. The thermos bottle effect created retards heating and eventual conversion of LOX to gaseous oxygen. Valves, tubing, and fittings incorporated in the converter assembly convert LOX to gas and direct its flow at a controlled rate.

CONFIGURATION AND FUNCTION

The type GCU-24/A Liquid Oxygen Converter Assembly (P/N 10C-0016-10) consists of a sphere assembly, buildup and vent valve, relief valve, pressure closing valve and associated tubing and fittings. A capacitance-type probe assembly, which sends an electrical signal to a

Table 12-15.—Troubleshooting (Emergency Pressure Test)

Trouble	Probable Cause	Remedy
High emergency pressure at 10 lpm flow	Emergency pressure control stem out of adjustment	Turn emergency pressure control stem clockwise
Low emergency pressure at 10 lpm flow	Emergency pressure control stem out of adjustment	Turn emergency pressure control stem counterclockwise
Low emergency pressure at 80 lpm flow	Elastic stop nut out of adjustment	Adjust elastic stop nut counterclockwise
Low TEST MASK pressure	Emergency pressure spring guide too short	Install longer emergency pressure spring guide
High TEST MASK pressure	Emergency pressure spring guide too long	Install shorter emergency pressure spring guide

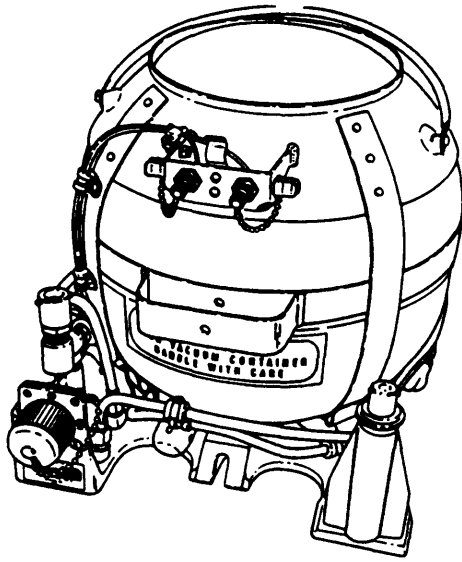

Figure 12-5.—Liquid oxygen converter assembly, type GCU-24/A, P/N 10C-0016-10.

liquid oxygen quantity gauge located in the aircraft, is incorporated within the sphere assembly. The quantity gauge indicates the amount of LOX, in liters, contained in the converter.

Operation and performance characteristics of the GCU-24/A converter assembly (P/N 10C-0016-10) are as follows:

1. The converter is filled by attaching the LOX servicing trailer filler valve to the filler port of the fill, buildup, and vent valve on the converter. When attached, the servicing trailer filler valve depresses the nosepiece and valve poppet of the fill, buildup, and vent valve. This automatically puts the converter into the fill mode (fig. 12-6). Figure 12-7 shows the converter installed in an aircraft.

2. With the poppet depressed, the fill and vent ports of the valve are opened, and the buildup port is closed. This condition allows gas pressure built up in the inner sphere to vent to the atmosphere. As pressure is vented, LOX in the servicing trailer (which is at a greater pressure-30 psig), flows through the fill, buildup, and vent valve and into the converter.

3. As the LOX level rises in the sphere, pressure created by vaporization of liquid due to heat, turbulence, etc., is vented to the atmosphere. The converter is considered full when LOX flows in a steady stream from the overboard vent line quick disconnect.

Table 12-16.—Leading Particulars for Liquid Oxygen Converter Assembly, Type GCU-24/A, P/N 10C-0016-10

Capacity (LOX)	10 liters
Operating pressure	70 psig
Operating temperature . . .	-65 °F (- 58.3 °C)
range	to + 260 °F (+ 127 °C)
Relief valve setting	100 to 120 psig
Pressure closing	70 to 80 psig
valve setting	
Delivery rate	120 lpm (min)
Filling time at 70 °F	10 min. at
(max)	30 psig
Buildup time (max)	5 min.

4. When the converter is full and the servicing trailer filler valve is disconnected, the nosepiece and poppet of the fill, buildup and vent valve return to the extended position (fig. 12-6). This automatically puts the converter into the buildup and supply mode by closing the fill and vent ports of the valve, and opening the buildup port.

5. In the buildup and supply mode (fig. 12-6), LOX is forced out of the bottom of the inner sphere and into the buildup coil by the weight of the liquid. As the LOX warms and vaporizes into gaseous oxygen in the buildup coil, pressure is created. This pressure is controlled at approximately 75 psig by the opening and closing action of the pressure closing valve.

6. Gaseous oxygen travels from the buildup coil through the supply quick disconnect and the heat exchanger to a shut-off valve in the aircraft cockpit.

7. Gaseous oxygen, under pressure, also passes through the gas and buildup ports of the fill, buildup and vent valve to the upper portion of the pressure closing valve, within which is a bellows. This bellows holds the valve in the open position. As pressure builds, the bellows, which senses the increase, contracts (at approximately 75 psig), and closes the valve.

8. Without a demand being placed on the converter, pressure continues to slowly rise. If

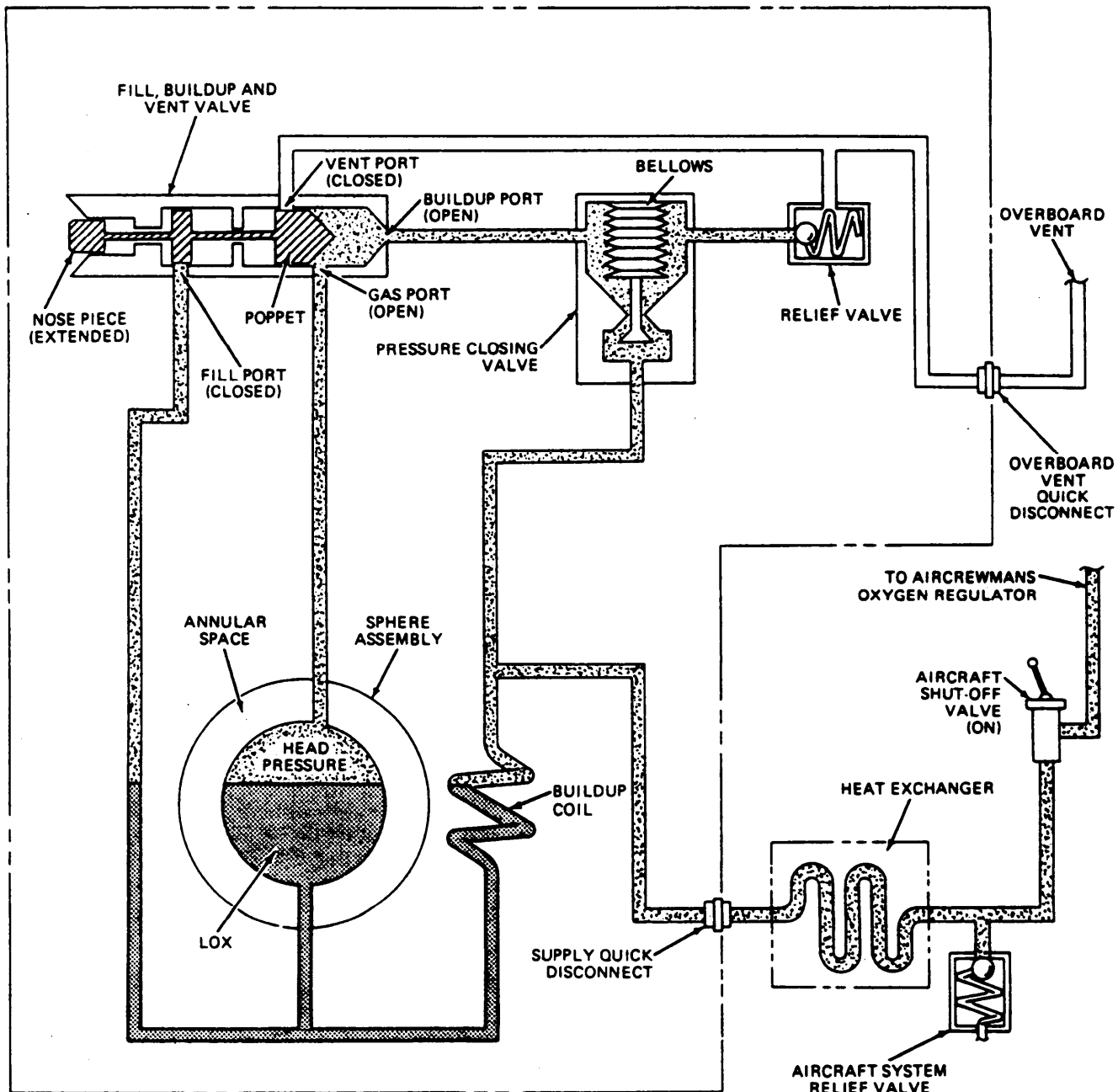

LEGEND



-  GASEOUS OXYGEN
-  LIQUID OXYGEN

Figure 12-6.-Buildup and supply mode (Converter Installed).

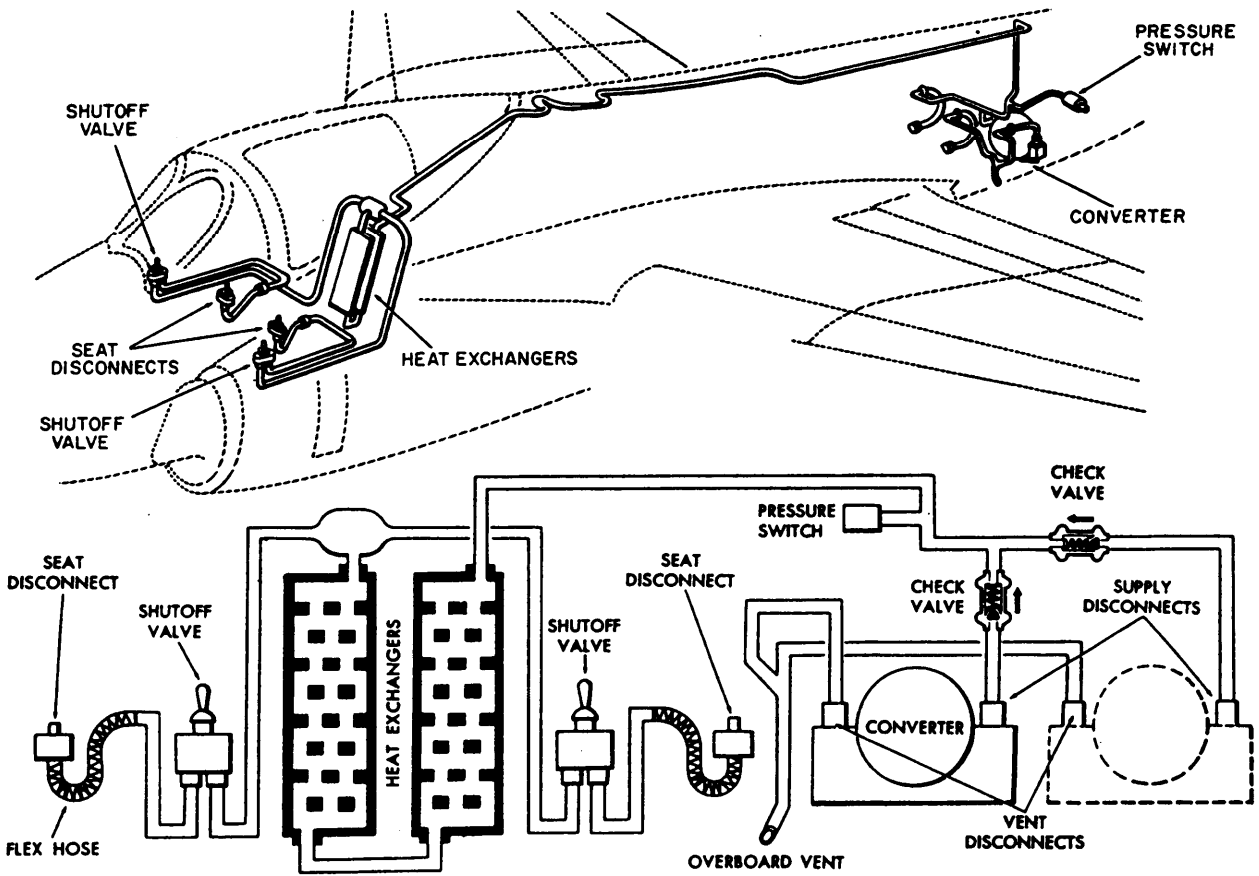

Figure 12-7.—Converter installed in an aircraft.

allowed to go unchecked, pressure in excess of 12,000 psig could be generated. To prevent this potentially hazardous situation, a relief valve is incorporated. The relief valve is set to relieve excess pressure in the converter assembly at approximately 110 psig.

9. As a demand is placed on the converter by the aircrewman, LOX is forced into the buildup coil to replace consumed oxygen. As this process is repeated, the LOX level in the converter drops, increasing the void area at the top. As the size of the void area increases, pressure decreases, and is sensed by the bellows in the pressure closing valve. When pressure falls below approximately 75 psig, the bellows expand, opening the valve. With the valve open, pressure from the buildup coil passes through the valve and into the top of the converter. This pressure, coupled with the pressure created by vaporizing LOX contained in the converter, again builds to approximately 75 psig and closes the pressure closing valve. This

process is repeated as long as a demand is being placed on the converter.

10. A heat exchanger is incorporated into the aircraft tubing to further warm the gaseous oxygen to a breathable temperature.

11. An additional relief valve, set at approximately 115 psig, is installed in the aircraft oxygen plumbing to provide additional protection against overpressurization of the converter and supply lines of the system.

PERFORMANCE TESTING

To be sure the converter is functioning, a series of bench tests is made. These tests are made using the test stand and the test stand calibration correction cards, shown in figure 11-6 in chapter 11 of this manual.

PERFORMANCE TEST SHEET
TYPE GCU-24/A LIQUID OXYGEN CONVERTER ASSEMBLY
(ESSEX CRYOGENICS P/N 10C-0016-10)

Date: _____ CONVERTER SERIAL NO: _____ TEST STAND SERIAL NO: _____

OPERATOR: _____ CDI: _____ TARE WEIGHT: _____

1. CONVERTER PURGE (PURGE 45 TO 75 MINUTES AT 200 °F (93 °C) TO 250 °F (121 °C) AND AT A MAXIMUM PRESSURE OF 55 PSIG).
2. INSULATION RESISTANCE TEST (EMPTY)

CONNECTION	MINIMUM ALLOWABLE MEGOHMS	READING
A TO B	2.0	
A TO GROUND	1.0	
B TO GROUND	1.0	

3. CAPACITANCE TEST (EMPTY) READING SHALL BE 121.5 TO 125.5 MICROMICROFARADS (UUF) _____
4. RELIEF VALVE TEST

VENT FLOW					LEAKAGE				
INLET PRESSURE (PSIG)		FLOW			INLET PRESSURE (PSIG)		FLOW		
ACTUAL	INDICATED	ACTUAL (LPM)	INDICATED (IN. H ₂ O)	READING	ACTUAL	INDICATED	ACTUAL (LPM)	INDICATED (IN. H ₂ O)	READING
100		100			95		0.01		
120									

5. CONVERTER LEAKAGE TEST

95 PSIG ACTUAL = _____ PSIG INDICATED. WITH INDICATED PSIG APPLIED THERE SHALL BE NO LEAKAGE FROM THE PRESSURE CLOSING VALVE, BUILDUP COIL, TUBING AND FITTINGS.

6. FILL AND BUILDUP TIME TEST

A. FILL TIME (MAXIMUM TIME ALLOWED IS 10 MINUTES) _____

B. BUILDUP TIME (MAXIMUM TIME TO BUILDUP TO 70 PSI IS 5 MINUTES) 70 PSIG ACTUAL = _____ PSIG INDICATED. TIME REQUIRED FOR BUILDUP _____ MINUTES

7. CAPACITANCE TEST (FULL)

TOTAL CONVERTER WEIGHT	
CONVERTER TARE WEIGHT	
LOX WEIGHT (W)	
$2.33 \times W + 124.7 = C$ (MAX)	
$2.25 \times W + 122.3 = C$ (MIN)	
READING	
C = CAPACITANCE IN UUF W = WEIGHT OF LOX IN POUNDS	

Figure 12-8.—Converter performance test sheet (Sheet 1 of 2).

8. EVAPORATION LOSS TEST (BUILDUP AND SUPPLY MODE) MAXIMUM ALLOWABLE LOSS OF LOX IN 24 HOURS IS 3.0 LBS.

NOTE: LOX IN CONVERTER MUST BE STABILIZED FOR 1 HOUR PRIOR TO BEGINNING TEST. DO NOT AGITATE CONVERTER DURING 24 HOUR PERIOD.

A. START TIME _____ START WEIGHT _____

B. FINISH TIME _____ FINISH WEIGHT _____

**9. EVAPORATION LOSS TEST (VENTED MODE)
MAXIMUM ALLOWABLE LOSS OF LOX IN 24 HOURS IS 5.0 LBS. (PERFORMED ONLY IF CONVERTER FAILS EVAPORATION LOSS TEST IN BUILDUP AND SUPPLY MODE)**

A. START TIME _____ START WEIGHT _____

B. FINISH TIME _____ FINISH WEIGHT _____

10. FLOW TEST (120 LPM WHILE MAINTAINING 55 TO 95 PSIG WORKING PRESSURE)

WORKING PRESS. (PSIG)		FLOW (LPM)		
ACTUAL	INDICATED	ACTUAL	INDICATED	READING
55		120		
90				

11. CONVERTER CHARGE

PRESSURE (PSIG)		
ACTUAL	INDICATED	READING
25		
30		

Figure 12-8.—Converter performance test sheet (Sheet 2 of 2).

PERFORMANCE TEST SHEET PREPARATION

Preparation of the liquid oxygen converter Performance Test Sheet (fig. 12-8), which is used for the performance test and for the bench test described later, requires entering the appropriate indicated flows and pressures in the spaces provided. The indicated flows and pressures are extracted from the test stand calibration correction cards (fig. 11-6 of chapter 11).

The test stand calibration correction cards contain all actual flows and pressures required to test all known models of liquid oxygen converters presently in service. Converting actual flows and pressures to indicated flows and pressures is normally accomplished during calibration of the

test stand. Refer to chapter 11 for calibration intervals.

The Performance Test Sheet is prepared as shown in figure 12-8. The Performance Test Sheet shown is a sample, but may be reproduced for local use.

The following tests require the extraction of appropriate indicated flows and/or pressures from the test stand calibration correction cards (figure 11-6 of chapter 11).

- Relief valve test
- Converter leakage test
- Fill and buildup time test

- Flow test
- Converter charge

RELIEF VALVE

The relief valve vents at least 100 liters per minute (lpm) with an applied pressure of 100 to 120 psig. The maximum allowable leakage with 95 psig applied is 0.01 lpm. Make the following entries on the performance test sheet:

1. Locate the indicated inches of water (inch of H₂O) for 100 lpm on correction card 4. Enter indicated inches of H₂O in the space provided on the performance test sheet.
2. Locate the indicated psig for the actual pressures of 95, 100 and 120 psig on correction card number 2. Enter indicated psig in space provided on performance test sheet.
3. Locate the indicated inches of H₂O for the actual flow of 0.01 lpm on correction card number 7. Enter the indicated in. H₂O in space provided on performance test sheet.

CONVERTER LEAKAGE

The converter leakage test is performed with the converter pressurized with gaseous oxygen to 95 psig. Locate the indicated psig for the actual 95 psig on correction card number 2. Enter indicated psig in space provided on performance test sheet.

FILL AND BUILDUP TIME

The time required to fill the converter (10 liters) should not exceed 10 minutes at a filling pressure of 30 psig.

The time required for the filled converter to buildup to a working pressure of 70 psig should not exceed 5 minutes from time the servicing trailer filler valve is disconnected from converter. Locate indicated psig for the actual 70 psig pressure on correction card number 2. Enter indicated psig in space provided on performance test sheet.

FLOW

The converter can deliver gaseous oxygen at a flow rate of 120 lpm while maintaining a

pressure of 55 to 90 psig. Make the following entries on the performance test sheet:

1. Locate the indicated inches of H₂O for the actual flow of 120 lpm on correction card number 4. Enter indicated inches of H₂O in space provided on performance test sheet.
2. Locate the indicated psig for actual pressures of 55 and 90 psig on correction card number 2. Enter actual psig in spaces provided on performance test sheet.

CONVERTER CHARGE

Upon completing the bench test, the converter is emptied of LOX, purged with nitrogen, and pressurized with gaseous oxygen at 25 to 30 psig. This prevents moisture from entering the converter during shipment/storage. Locate the indicated psig for the actual pressures of 25 to 30 psig on correction card number 2. Enter indicated psig in spaces provided on the performance test sheet.

MAINTENANCE

This section contains the procedural steps for inspecting, testing, troubleshooting, disassembly, cleaning, repair, assembly and adjusting of the GCU-24/A liquid oxygen converter assembly (P/N 10C-0016-10).

Procedural steps outlined in this section are listed under the inspection cycle in which they are required, and in the sequence in which they normally occur.

ACCEPTANCE/TURNAROUND/ DAILY/PREFLIGHT/POSTFLIGHT AND TRANSFER INSPECTIONS

The acceptance/turnaround/daily/preflight/postflight and transfer inspections consist of a visual inspection followed by a functional test. These inspections and tests are performed along with the aircraft inspection requirements for the aircraft in which the converter is installed. In making the following checks, if you discover any defects, refer to table 12-17 for troubleshooting assistance.

Table 12-17.—Troubleshooting (Acceptance/Turnaround/Daily/Preflight/Postflight and Transfer Inspections)

Trouble	Probable Cause	Remedy
Converter will not fill	Ice in filler valve or filler line obstructs LOX flow	Thaw filler valve/filler line
Converter does not fill in required time	Filler line not properly purged prior to filling	Purge and cool filler line
	Converter not sub-cooled before filling	Lower pressure in servicing trailer and sub-cool converter
	Filling pressure too low	Increase pressure to 30 psig.
	Defective converter	Replace converter
Frost collects on entire outer jacket of converter	Heat loss due to annular space leakage	Replace converter
Converter will fill only partially (gas only emitted from vent)	Converter not sub-cooled prior to filling	Lower pressure in servicing trailer and sub-cooled converter
System will not build up	Buildup, vent and filler valve defective, or partially open	Replace converter, or thaw valve
	Pressure relief valve open	Replace converter
Oxygen supply consumed too quickly	Converter not completely filled during filling operation	Refill converter
	System leakage	Locate and repair leaks
	Buildup, vent and filler valve partially open, venting gas	Thaw valve
Filler line cannot be disconnected from filler valve	Filler nozzle frozen to filler valve	Thaw nozzle
Low, or no system pressure	System leakage	Locate and repair leaks
	Pressure closing valve out of adjustment	Replace coverter
Quantity gage indicates empty	System empty, defective probes or gage	Refill, replace coverter or gage
LOX system contaminated	Undesirable odors, or moisture	Purge system

VISUAL INSPECTION

Visually inspect the converter assembly and surrounding area for the following:

1. Freedom from dirt and hydrocarbons.
2. Correct installation and positioning of all components, safety wire, and Glyptal dots.
3. Legibility of all markings.
4. Cracks, dents or other damage to tubing, valves and electrical connections.
5. Corrosion on converter assembly and surrounding areas.
6. Obstructions in aircraft overboard vent line.

7. Security of supply, vent and electrical quick-disconnects.

8. Excessive frosting of converter assembly.

9. Ensure date on converter bench test decal is current (within last 231 days).

FUNCTIONAL TEST

In addition to the scheduled test, the functional test should also be performed by the AME whenever a component of the aircraft oxygen system is removed/replaced. As a PR you may be called upon to perform this test. To

functionally test the converter assembly and aircraft oxygen system, proceed as follows:

1. Ensure all circuit breakers associated with the LOX quantity indicating system are set. External electrical power must be applied to the aircraft to perform steps 2 and 3 below.

2. Depress oxygen test switch. Check the quantity gauge and low warning light for proper operation. Refer to the applicable aircraft Handbook of Maintenance Instructions (HMI) to determine at what quantity (indicated on quantity gauge) that the low warning light should illuminate.

3. Release test switch. Ensure gauge pointer returns to position registered on gauge before depressing. When test is completed, disconnect electrical power for aircraft.

4. Ensure oxygen shutoff valve is in the OFF position.

5. Attach an oxygen mask, regulator and regulator-to-seat kit hose assembly to oxygen supply connection in aircraft.

6. Turn oxygen shutoff valve to the ON position. There should be a flow of oxygen through the mask.

7. Place the mask against your face and breathe. There should be a slight resistance during exhalation. This resistance is due to the positive pressure feature of the regulator.

8. Upon completing the functional test, turn the oxygen shutoff valve to OFF. Disconnect the regulator-to-seat kit hose from the aircraft supply connection.

If discrepancies are found or suspected, notify maintenance control.

Components of the aircraft oxygen system that do not pass inspection and cannot be repaired in the aircraft are removed and replaced by ready for issue (RFI) components.

CALENDAR INSPECTION

All liquid oxygen converters are given the calendar inspection before they are placed in

Table 12-18.—Visual Inspection of Type GCU-24/A Liquid Oxygen Converter (P/N 10C-0016-10)

Part Nomenclature	Inspect for	Remedy
Identification and performance plates	Legibility, condition and security	Secure in place or replace
Warning and bench test decals	Presence and condition	Replace or apply as required
Handle	Bends and cracks	Replace
Tubing assemblies	Cracks, dents, nicks, scratches, twists and proper clearance. Damaged connectors and tube nuts	Replace damaged tubing assemblies and connectors. Tubing may be slightly bent to maintain a minimum 1/16-inch clearance between other converter components.
Elbow and nipples	Cracks, dents and scratches	Replace
Male quick-disconnects	Visible damage	Replace
Supply manifold assembly	Visible damage	Replace
Fill, buildup and vent valve	Cracks, damaged poppet valve, nosepiece or work helical grooves	Replace
Clamps	Security and condition	Tighten or replace
Pressure relief and pressure closing valve	Cracks or other visible damage. Presence and condition of lock wire on relief valve	Replace. Replace lock wire on relief valve
Mounting strap, mounting cradle and mounting base assembly	Cracks, broken welds, chipped paint or other visible damage.	Replace. Restore finish by painting
Sphere assembly	Excessive dents, chipped paint or other damage. Not to exceed 3/8" deep	Restore finish by painting
Converter assembly	Freedom from dirt, hydrocarbons and corrosion	Clean and/or refinish

service, and at intervals not exceeding 231 days thereafter. This interval applies to all converters; aircraft-installed, shop spares, and those maintained in a servicing pool.

The calendar inspection consists of a visual inspection followed by a bench test. All work is performed in a clean, dust-free and oil-free area. Converter assemblies found to be damaged or out of adjustment are repaired by replacing or adjusting the discrepant part or parts. After repair, repeat the bench test.

VISUAL INSPECTION

Visually inspect the converter assembly in accordance with table 12-18.

Liquid oxygen converters failing the visual inspection or bench test are repaired, if the specific repair is authorized. SM&R maintenance is authorized to perform repairs. Further explanation is found in *Naval Aviation Maintenance Program (NAMMP)*, OPNAV 4790.2 (series).

SERVICE LIFE

Liquid oxygen converters can remain in service as long as they continue to function properly.

BENCH TEST

The bench test is performed using the Liquid Oxygen Converter Test Stand P/N 59A120, 31TB1995-1 or 31TB1995-4. Refer to chapter 11 for identification of test stand controls and indicators referenced in bench test procedures. Do not attempt to perform any bench test without first becoming thoroughly familiar with the test stand. Use Performance Test Sheet (fig. 12-8) when performing the bench test.

The following tools and materials are required for this test:

<u>Quantity</u>	<u>Description</u>	<u>Reference Number</u>
1	Gas/LOX Purging Unit	90000-1, 901760-1 or equivalent
1	Scale (at least 50-lb capacity)	TE 213 or equivalent
1	Gauge, Oxygen, 0-200 psig (Refer to NAVAIR 13-1-6.4)	565-3A or equivalent
1	Coupling, Quick-disconnect (female)	199000-1
1	Thermometer, Self-indicating	GG-T-336 Type 2, Class D or equivalent
As Required	Compound, leak detection	MIL-L-25567

In the following descriptions, the tests are arranged so they proceed from one test to the next with a minimum of flow changes. Troubleshooting tables accompany many of the tests.

The first step in the bench test is to find the tare weight of the converter. Tare weight is the weight of the complete converter assembly less the weight of the LOX. Proceed as follows:

1. Ensure all LOX has been removed from the converter.
2. Place the converter assembly on scales having at least a 50-pound capacity. Record weight in space provided on performance test sheet.

CONVERTER ASSEMBLY PURGE

As we mentioned before, the converter should be purged before any test. This purging is the key to a trouble-free operating converter. Only dry, oil-free nitrogen, Type I, Class 1, Grade A (FED SPEC BB-N-411) is to be used for purging converters. While operating purging unit, you have to wear protective gloves. The discharge fittings can reach temperatures that will cause severe burns if grasped with bare hands.

Before starting to purge the unit, empty it of LOX and allow it to warm to room temperature. Then proceed as follows:

1. Cap the converter quick-disconnect coupling assembly and attach a drain line to the quick-disconnect coupling assembly.
2. Ensure the purge unit power switch is OFF. Connect the purging unit electrical power cable to a suitable electrical power source.
3. Open the N₂ supply cylinder valve and the purge unit inlet valves.
4. Turn the purge unit power switch ON, and allow the unit to warm up approximately 10 minutes.
5. Measure the outlet temperature of the purge unit using a thermometer, GG-T-336, Type 2, Class D or equivalent. Temperature should be between 200 °F (93 °C) and 250°F (121 °C) prior to connecting the purge unit to converter.
6. Connect the purging unit to the fill, buildup, and vent valve of converter.
7. Purge the converter assembly. The maximum inlet pressure and temperature should be 55 psig and 250 °F, respectively. The purge time for 10-liter LOX converters which are at ambient temperature is from 45 to 75 minutes.

8. When purging is completed, turn the purge unit power switch OFF, secure the N₂ supply cylinder valve and the purge unit inlet valves. Disconnect the purge unit from the converter.

NOTE: Should the unit fail a test, the first step of the repair action is to repurge the unit.

INSULATION RESISTANCE TEST (EMPTY)

To perform the insulation resistance test, proceed as follows:

1. Secure the empty converter in the rack provided on the test stand countertop.

2. Using the test stand cable assembly, connect the upper terminals of the high capacitance cable assembly to terminals A and B of the liquid oxygen quantity gauge capacitance type tester.

3. Turn the power switch ON and allow the tester to warmup 10 minutes prior to proceeding.

4. Turn the MEGOHMMETER RANGE SELECTOR to its X-1 position.

5. Turn the FUNCTION SELECTOR knob to the A AND B position. Record the reading on the meter in the space provided on the Performance Test Sheet. Reading should not be less than 2.0 megohms.

6. Turn the FUNCTION SELECTOR knob to A TO GROUND and B TO GROUND positions respectively. Record the readings in spaces provided on the Performance Test Sheet. Readings should not be less than 1.0 megohm in either position.

7. If insulation resistance readings are less than allowed, connect the cable assembly to the lower probe terminals, and repeat steps 5 and 6.

8. If readings are acceptable, replace the high capacitance cable with the low capacitance assembly. Repeat steps 5 and 6. If readings are acceptable, proceed to step 11.

9. If readings continue to be less than acceptable, moisture may still be present in the sphere assembly. Purge the converter and repeat the test.

10. Converter assemblies that fail the insulation resistance test, and cannot be corrected by replacing the low or the high capacitance cable assembly or by purging, are condemned.

11. Leave all connections unchanged and start the capacitance test (empty).

CAPACITANCE TEST (EMPTY)

To perform the capacitance test, proceed as follows:

1. Turn the CAPACITANCE RANGE SELECTOR knob to the X-10 position.

2. Turn the FUNCTION SELECTOR knob to its CAPACITANCE (UUF) position.

3. Record the meter reading in the space provided on the Performance Test Sheet. Reading should be 121.5 to 125.5 micro-microfarads (UUF).

4. If this reading is not within these limits, moisture may still be present in the sphere. Purge converter again and repeat the capacitance test.

5. Converter assemblies that fail the capacitance test and cannot be corrected by purging are condemned.

6. Turn the power switch off and disconnect the test stand cable assembly.

RELIEF VALVE TEST

To follow this description, you will find it helpful to refer back to figure 11-4 of the test stand in chapter 11. To perform the relief valve test, proceed as follows:

1. Disconnect low and high capacitance cable assemblies from lower probe terminals.

2. Disconnect the buildup tube assembly from the buildup port of the fall, buildup and vent valve, and from the pressure closing valve. Hold the 45-degree elbows with open-end wrench to prevent turning while loosening tube nut connections.

3. Cap 45-degree elbow in buildup port of fill, buildup and vent valve.

4. Using Test Stand Hose Assembly, P/N 59A120-B5-14, connect test stand BELL JAR BOTTOM COUPLING C-1 to the 45-degree elbow on converter pressure closing valve.

5. Using the Test Stand Hose Assembly P/N 59A120-B5-52, connect the converter quick-disconnect coupling to the test stand FLOWMETER CONNECTION, NIP-4.

6. Turn the FLOWMETER SELECTOR valve V-1 to the 0-150 lpm position. Open the TEST PRESSURE GAUGE-TO-BELL JAR valve, V-2.

7. Open the OXYGEN SUPPLY valve, V-6, slowly. Damage to test stand gauges could result from rapid surges in pressure if this valve is opened too rapidly. Pressure applied will be indicated on TEST PRESSURE GAUGE, PG-1.

8. The relief valve relieves a minimum rate of 100 lpm, as indicated on the FLOWMETER

INDICATOR GAUGE, PG-2, with a pressure of 100 to 120 psig, as indicated on the TEST PRESSURE GAUGE, PG-1, applied to the converter. Record these readings on the Performance Test Sheet.

9. Using the OXYGEN SUPPLY valve, V-6, and the SYSTEM BLEED valve, V-5, reduce the pressure applied to the converter to 95 psig as indicated on gauge PG-1.

10. Disconnect the test stand hose from the FLOWMETER CONNECTION, NIP-4 and reconnect it to the FLOWMETER CONNECTION, NIP-1.

11. Turn the FLOWMETER SELECTOR valve V-1 to the 0.0-0.25 lpm position.

12. While maintaining 95 psig to the converter with valve V-6, check for leakage indicated on the FLOWMETER INDICATOR, PG-2. Maximum allowable leakage is 0.01 lpm. Record this reading on the Performance Test Sheet.

13. If leakage is excessive, or if the relief valve fails to vent at the required flow and pressure, locate the probable cause using Troubleshooting Chart Relief Valve Test (Table 12-19).

14. Close OXYGEN SUPPLY valve, V-6. Bleed the test stand using SYSTEM BLEED valve, V-5. Close TEST PRESSURE GAUGE-TO-BELL JAR valve, V-4.

15. Disconnect both the test stand hose assemblies from the converter and from the test stand.

16. Uncap the 45-degree elbow that you capped in step 3, and reconnect the buildup tube, which you removed in step 2.

17. Reconnect the high and low capacitance cable assemblies, which you removed in step 1. At this time, ensure that all safety wired setscrews have the proper Glyptal dots applied.

CONVERTER LEAKAGE TEST

To test the converter for leaks, proceed as follows:

1. Using Test Stand Hose Assembly, P/N 59A120-B5-47, connect the test stand BELL JAR BOTTOM COUPLING C-1 to the converter quick-disconnect coupling.

2. Open the TEST PRESSURE GAUGE-TO-BELL JAR valve, V-2.

3. Using the OXYGEN SUPPLY valve, V-6, slowly apply 95 psig, as indicated on TEST PRESSURE GAUGE, PG-1, to the converter.

4. Maintain 95 psig and inspect for leakage at all connections using leak detection compound (MIL-L-25567). There should be no leakage. If any leakage is found, locate its probable cause using the troubleshooting chart (table 12-20).

Table 12-19.-Troubleshooting (Relief Valve Test)

Trouble	Probable Cause	Remedy
Relieving below 100 psig	Relief valve out of adjustment	Turn adjusting screw counterclockwise
Relieving below 120 psig	Relief valve out of adjustment	Turn adjusting screw clockwise
Relief valve fails to vent 100 lpm	Relief valve out of adjustment	Turn adjusting screw clockwise
Leakage in excess of 0.01 lpm	Relief valve out of adjustment	Turn adjusting screw counterclockwise
Relief valve cannot be adjusted to tolerances	Defective parts	Replace relief valve

Table 12-20.-Troubleshooting (Converter Leakage Test)

Trouble	Probable Cause	Remedy
Any fitting connection leaking	Loose connection	Tighten connection
Elbow or nipple fitting leaking	Stripped threads, excessive burrs, deep scratches, inside or outside diameter out of round or loose	Tighten or replace fitting(s)
Tubing leaking	Dents, kinks, deep scratches, twisted tubing, improperly flared ends or damaged connectors	Replace tubing

5. Close OXYGEN SUPPLY valve V-6. Bleed the test stand using SYSTEM BLEED valve V-5. Close TEST PRESSURE GAUGE-TO-BELL JAR valve V-2.

6. Remove the converter assembly from test stand.

FILL AND BUILDUP TIME TEST

To perform the fill and buildup time test, it will be necessary to take the converter to a LOX servicing area, or use a LOX servicing trailer in the immediate area of the oxygen shop. Any other method is acceptable that meets requirements of the test, and does not violate safety precautions. Remember, LOX requires special precautions.

Once the converter is in a satisfactory location, proceed as follows:

1. Attach a vent drain line to the converter quick-disconnect coupling. This line should be long enough to route venting LOX away from all personnel.

2. Attach the pressure gauge/relief valve test fixtures to the supply quick-disconnect coupling (refer to NAVAIR 13-1-6.4).

3. Attach the servicing trailer filler valve to the converter fill, buildup, and vent valve.

4. Note the time, and start filling the converter. Maintain a filling pressure at 30 psig.

5. The converter is full when a steady stream of LOX flows from the drain line. When the converter is full, note the time. The time required to fill the converter at 30 psig should be no longer than 10 minutes. Record the fill time in the appropriate space on the Performance Test Sheet.

6. Note the time, and disconnect and secure the servicing trailer. The time noted at this point is the beginning of the buildup time test.

7. Observe the pressure gauge on the quick-disconnect coupling. On the performance test sheet, record the time it takes the converter assembly to buildup to a working pressure of 70 to 80 psig. This time should not exceed 5 minutes.

8. If discrepancies were noted in either part of the test, locate the probable cause using the troubleshooting chart (table 12-21).

9. Remove the vent drain line and the pressure gauge/relief valve test fixture you installed in steps 1 and 2.

CAPACITANCE TEST (FULL)

The capacitance test requires simultaneous use of the 50-pound scales and the quantity gauge capacitance type tester incorporated in the test stand. Ensure the scales are positioned close enough to the tester, then proceed as follows:

1. Place the full converter on the scales.

2. Using the test stand cable assembly, connect the upper terminals of the converter high and low capacitance cable assemblies to terminals A and B, respectively, of the liquid oxygen quantity gauge capacitance type tester.

3. Turn the power ON and allow the tester to warm up 10 minutes before proceeding.

4. Turn the CAPACITANCE RANGE SELECTOR knob to its 10X position.

5. Turn the FUNCTION SELECTOR knob to the CAPACITANCE (UUF) position.

6. Enter the total weight of the full converter in the space provided on the performance test sheet.

7. Subtract the tare weight of the converter from its total weight. Enter this figure on the Performance Test Sheet. This is the weight of LOX in the converter.

8. Using the formula given on the Performance Test Sheet, $2.33 \times W + 124.7 = C(\max)$, calculate the capacitance maximum (C-max). Use the weight of LOX for W. Enter the result of the calculation in the space provided.

9. Use the formula $2.25 \times W + 122.3 = C(\min)$ and calculate the capacitance minimum (C-tin) on the next line of the test sheet. Use the weight of LOX for W.

Table 12-21.—Troubleshooting (Fill and Buildup Time Test)

Trouble	Probable Cause	Remedy
Failure of converter to fill in prescribed time	Defective fill, buildup and vent valve	Replace fill, buildup and vent valve
	Pressure closing valve out of adjustment or defective	Adjust or replace pressure closing valve
Failure of converter to reach operating pressure within prescribed time	Pressure closing valve out of adjustment or defective	Adjust or replace pressure closing valve

10. Observe and record capacitance reading from test stand capacitance gauge in space provided on Performance Test Sheet. Reading should be between C(max) and C(min).

11. If the test is not within these limits and the converter has not been purged in previous tests, there may be moisture in the sphere. Purge the converter and refill it with LOX, then repeat steps 1 through 11.

12. If the converter is still not within limits, condemn the converter.

13. Secure the tester and disconnect the cables from the converter and tester. If the converter passes capacitance test, carefully remove it from the scales and allow it to remain undisturbed for 1 hour.

EVAPORATION LOSS TEST (BUILDUP AND SUPPLY MODE)

To perform the evaporation loss test in the buildup and supply mode, proceed as follows:

1. At the end of the 1 hour period, gently place the converter on the scales and record its weight and the start time in the spaces provided on section 8 of the Performance Test Sheet.

2. Place the converter assembly aside again and allow it to remain undisturbed for 24 hours.

3. At the end of the 24-hour period, carefully replace the converter on the scales.

4. Record the time and weight in the spaces provided on the Performance Test Sheet. The 24 hour weight loss must be less than 3 pounds. There should not be a heavy coat of frost on the sphere.

5. If the weight loss was 3.0 pounds or less, and there was not excessive frosting of the sphere assembly, proceed to the flow test. If the loss was more than 3.0 pounds, proceed to the EVAPORATION LOSS TEST.

EVAPORATION LOSS TEST (VENTED MODE)

Maximum allowable loss of LOX in 24 hours is 5.0 pounds. Minimum allowable loss is defined as the weight recorded during the buildup and supply mode minus 0.5 pound (performed only if converter fails evaporation loss test in buildup and supply mode).

To perform the evaporation loss test in the vented mode, proceed as follows:

1. With the converter still on the scales, attach the test stand fill valve adapter (P/N 59A120-D5-10) to the fill, buildup, and vent valve on the converter.

WARNING

VENTING A CONVERTER THAT IS IN A BUILDUP AND SUPPLY MODE CAUSES A BLAST OF LOX FROM THE VENT PORT. ENSURE THAT VENT BLAST IS DIRECTED AWAY FROM ALL PERSONNEL, AND THAT ADEQUATE CLOTHING AND FACIAL PROTECTION ARE WORN.

2. Turn the knurled knob of the adapter in until it seats. This places the converter in the vented mode.

3. Record the time and weight in section 9 of the Performance Test Sheet.

4. Place the converter aside and allow it to remain undisturbed in the vented mode for 24 hours.

5. At the end of the 24-hour period, carefully replace the converter on the scales.

6. Record the time and the converter weight on the Performance Test Sheet. Weight loss in 24 hours should not exceed 5.0 pounds for this test to be satisfactory.

7. If the weight loss is too much, locate the probable cause by using the troubleshooting chart in table 12-22.

Table 12-22.—Troubleshooting (Evaporation Loss Test)

Trouble	Probable Cause	Remedy
Excessive weight loss (evaporation loss test (vented))	Loss of vacuum in sphere assembly	Replace converter assembly
Excessive weight loss (evaporation loss test (buildup and supply mode))	Excessively leaking valves, leaking tubing and/or fittings	Replace valves, tighten or replace fittings. Repeat converter leakage test
Frosting of sphere assembly	Loss of vacuum in sphere	Replace converter assembly

Table 12-23.-Troubleshooting (Flow Test)

Trouble	Probable Cause	Remedy
Converter fails to maintain operating pressure	Pressure closing valve out of adjustment	Adjust or replace pressure closing valve

8. Remove the fill valve adapter you installed in step 1.

FLOW TEST

To perform the flow test, proceed as follows:

1. Secure the converter in the rack on the test stand countertop.

2. Using the Test Stand Hose Assembly, P/N 59A120-B5-12, connect the test stand FLOWMETER CONNECTION, NIP-4, to the CONVERTER SUPPLY OUTLET CONNECTION, NIP-5.

3. Using the Test Stand Hose Assembly, P/N 59A120-B5-47, connect the test stand SUPPLY TO CONVERTER CONNECTION, NIP-6, to the converter quick-disconnect coupling.

4. Place the test stand FLOWMETER SELECTOR valve V-1 in the 0-150 lpm position. Open the TEST PRESSURE GAUGE BUILDUP AND FLOW valve V-10. You should not have a reading of over 70 psig on the test pressure gauge PG-1. If the test pressure gauge reads over 70 psig, vent the converter system pressure to 70 psig (refer to NAVAIR 13-1-6.4).

5. Open the test stand CONVERTER SUPPLY FLOW CONTROL valve, V-9, to give a flow of 120 lpm as indicated on the FLOWMETER INDICATOR gauge, PG-2. Maintain the flow for a minimum of 15 minutes.

6. While maintaining a 120 lpm flow, the converter should maintain pressures of 55 to 90 psig as indicated on the TEST PRESSURE gauge, PG-1. Record the high and low pressures in the indicated blocks in section 10 of the Performance Test Sheet.

7. If the converter supply pressure is not within limits, locate probable cause using the troubleshooting chart (table 12-23).

8. Continue flowing the converter until it is completely empty of LOX. Any means of evacuating LOX from the converter is acceptable, provided all safety precautions are followed.

9. Disconnect the test stand hose assemblies, which you attached in steps 2 and 3. Close all test stand valves.

CONVERTER CHARGE

Upon completion of the bench test, the converter is charged with gaseous oxygen to 25 to 30 psig to prevent entry of moisture and other contaminants during shipment/storage. To charge the converter, proceed as follows:

1. Secure the converter in the rack on the test stand countertop, unless it is already there.

2. Using the Test Stand Hose Assembly, P/N 59A120-B547, connect the test stand BELL JAR

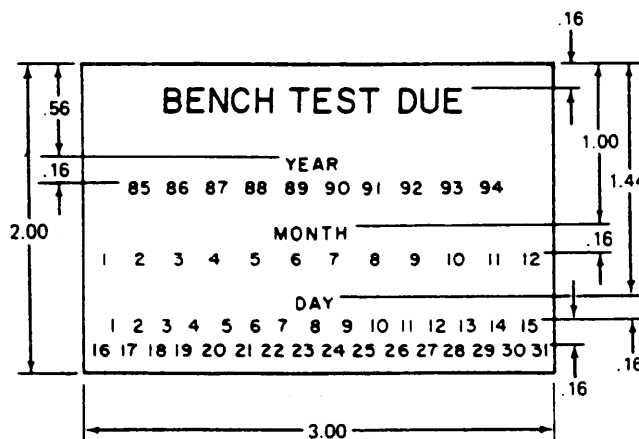

NOTES:

1. MATERIAL SHALL BE ELASTOMERIC PRESSURE SENSITIVE TYPE ADHESIVE BACKED, IN ACCORDANCE WITH MIL-M-43719, TYPE I, CLASS 1.
2. ALL LETTERS AND NUMBERS SHALL APPROXIMATELY MATCH GREEN NO. 14187 OF FED. STD. NO. 595; BACKGROUND SHALL APPROXIMATELY MATCH WHITE NO. 17875 OF FED. STD. NO. 595.
3. BENCH TEST DUE SHALL BE 18-POINT GOTHIC (SANS SERIF) LETTERING. ALL OTHER NUMBERS AND LETTERS SHALL BE 10-POINT, GOTHIC (SANS SERIF).

Figure 12-19.—Bench test decal.

BOTTOM COUPLING, C-1, to the converter quick-disconnect coupling.

3. Open the TEST PRESSURE GAUGE-TO-BELL JAR valve, V-2.

4. Opening the OXYGEN SUPPLY valve, V-6, slowly charge the converter to 25 to 30 psig. Pressure will be indicated on the TEST PRESSURE gauge, PG-1.

5. Close the OXYGEN SUPPLY valve, V-6. Disconnect the hose assembly connected in step 2, and bleed the test stand using SYSTEM BLEED valve, V-5. Secure all test stand valves.

6. At this point, enter the amount of the converter charge in section 11 of the Performance

Test Sheet, and you and a CDI sign the sheet. The original, or a copy of the Performance Test Sheet is forwarded to the operational custodian of the converter.

7. Mark the due date of the next bench test on the bench test decal (fig. 12-9). Due date is 231 days from the last bench test date. Affix this decal to the converter in a position in which it will be visible when the converter is installed in an aircraft.

8. Install dust covers or plugs in/on all open couplings prior to shipping or storage of the converter.

APPENDIX I

GLOSSARY

ABRASION—A fuzzy spot or area on cloth, usually caused by rubbing against an object.

ACC—Abbreviation for aircrew systems change.

ACCORDLAN-FOLDS—Folding a canopy into S-shaped layers of predetermined size. Accordion folding produces a packaged parachute assembly in the desired finished shape.

ACID—A fundamental chemical class distinguished by having reactive hydrogen radicals (pH below 7.0). Acids can be extremely corrosive to metal and damaging to fabric.

ADAPTER, HARNESS—A rectangular metal fitting with a fixed crossbar used primarily as an anchoring point.

ADAPTER, HARNESS FRICTION—A rectangular metal fitting with a movable center bar (friction grip). Facilitates quick adjustment of a harness by the wearer.

AIRCREW MEMBER—An aircraft crew member. Passengers are not considered aircrew members.

ALKALINE—A substance that is opposite to an acid, a base. Also, any substance that has the properties of an alkali (metallic hydroxide).

ANEROID—A corrugated metal capsule used in the automatic parachute ripcord release for sensing atmospheric pressure. The aneroid will initiate operation of an actuator at a preset altitude.

ANTI-SEIZE TAPE—A tape of any of several thin plastic-film materials (such as tetrafluoroethylene) characterized by a waxy, oily texture, and used to prevent binding between mating surfaces of threaded parts when applied to the male threaded portion.

APPROX—Abbreviation for approximately.

ASSEMBLY—A grouping of parts fitted together to form a complete unit.

ATMOSPHERIC PRESSURE—Pressure at sea level, expressed as 14.696 pounds per square inch, absolute, or 29.92 inches mercury column (barometer). See also PSIA and IN. HG.

AUTOMATIC PARACHUTE RIPCORD RELEASE—A barometrically controlled device that mechanically or by explosive force actuates the parachute ripcord assembly, causing the parachute container to open at a preset altitude.

AWL—A pointed tool for piercing small holes in cloth, leather, wood, and other soft materials.

BACKSTITCH—A stitch made by inserting the needle a stitch length to the right and bringing it up an equal distance to the left. Also, sewing back over a row of stitches.

BAG, SHOT—A bag filled with lead shot used to hold the canopy in place during packing.

BAG, DEPLOYMENT—A canvas enclosure for the canopy and suspension lines. In use, the deployment bag controls release of suspension lines and canopy, ensuring orderly opening.

BALL, CABLE RETAINING—A steel ball that is swaged to the ripcord cable and secures the ripcord handle to the cable.

BAND, LATERAL—Webbing inserted in canopy skirt and vent hems to reinforce edges and distribute load.

BAND, POCKET—A piece of tape or line attached at the skirt hem and across the radial seam, which causes the gores to be pulled outward

at inflation, thus improving the opening characteristics of the canopy.

BAND, RETAINING—A rubber band used to hold folded suspension lines in a container or faked lines together.

BARREL, AUTOMATIC PUCHUTE RIPCORD RELEASE—That part of an automatic parachute ripcord release that houses the cartridge and piston or spring and piston.

BARTACK—A concentrated series of zig-zag stitches used to reinforce points of stress. A bartack should have 28 stitches per half-inch (per MIL-O-81900AS).

BEESSWAX—A wax, generally with paraffin, that is applied cold or melted to thread to prevent raveling or cloth unknitting and to make thread easier to sew.

BIAS CONSTRUCTION—A type of canopy construction in which the canopy cloth is cut and sewn so that the centerline of each gore runs at a 45-degree angle to the warp and filling thread of the canopy cloth.

BINDING—A piece of tape or fabric folded over and stitched to a raw edge of cloth to prevent raveling or fraying.

BODKIN—A large-eyed, blunt needle instrument for inserting thread, tape, ribbon, or line through a loop, hem, or channel. Used to feed suspension lines through canopy radial seams or to stow suspension line bights in certain parachute container assemblies.

BOLT—A package or roll of cloth of varying widths. Also, a measuring term for 40 yards of material.

BOTTOM, FALSE—A piece of cloth sewn to the inside of a pack to retain the frame. It also serves as a base for attaching suspension line hesitater loops.

BRAID—A narrow band of interlaced strands.

BREATHING—The pulsating action of the parachute canopy when fully inflated.

BUNCHED STITCHING—Stitches too close or more stitches per inch than required.

BURL—A knot or lump in thread or cloth.

BURNS, FRICTION—A hard spot on the suspension line caused by two lines rubbing together at high speeds, generally off-color and brittle.

C—Abbreviation for Celsius.

CABLE, ARMING, AUTOMATIC PARACHUTE RIPCORD RELEASE—A cable that, when attached to the ejection seat, lap belt, or other designated point, arms the automatic parachute ripcord release at seat/man separation.

CABLE, POWER, AUTOMATIC PARACHUTE RIPCORD RELEASE—A cable covered by a housing, which transmits the force from the automatic ripcord release assembly to the ripcord cable.

CABLE, RIPCORD—A flexible cable joining the locking pins and ripcord handle.

CANOPY—The main supporting surface of a parachute that, when opened, reduces the rate of descent. It is usually made of nylon and includes a framework of cords, called suspension lines, from which the load is suspended.

CANOPY, CONICAL—A canopy constructed in the shape of a cone. See also **CANOPY**.

CANOPY, EXTENDED SKIRT—A canopy that has a flat circular center or disk when spread out. See also **CANOPY**.

CANOPY, FLAT CIRCULAR—A canopy that has the shape of a flat circle or disk when spread out. See also **CANOPY**.

CANOPY, GUIDE SURFACE—A mushroom-shaped canopy in which alternate roof panels are extended to provide guide surfaces. See also **CANOPY**.

CANOPY, HEM-RIGGED—A canopy that the suspension lines are attached to the skirt hem and do not pass over the drag-producing surface; for example, the 26-foot conical canopy. See also **CANOPY**.

CANOPY, RIBBON—A canopy composed of concentric cloth ribbons, supported by radial ribbons and tapes. See also **CANOPY**.

CANOPY, RINGSAIL—A canopy composed of concentric rings installed on a spherical surface. The slots that are contained in the gores are in the form of a crescent. See also **CANOPY**.

CANOPY, RING SLOT—A canopy composed of concentric cloth strips with intervening air slots. The number of slots will vary with the diameter of the canopy. See also **CANOPY**.

CANVAS—A heavy, closely-woven cloth of linen, cotton, or synthetic fiber.

CASING (SLEEVE)—The outer woven cover of the suspension line.

CAUTION—Indicates danger to equipment. The caution precedes the step or item to which it refers.

CcM—Abbreviation for cubic centimeters per minute.

CDI—Abbreviation for collateral duty inspector.

CHANNEL, CANOPY—The space or opening formed by the overlapping of cloth in making of radial seams. The suspension lines pass through the channels and are retained in position. The channels aid in transmitting load from the lines to the cloth.

CHUTE—Abbreviated slang form of parachute.

CLAMP, DUAL HOUSING—A metal clamp located on the outside of the end flap of back-and seat-type parachutes. The clamp secures the ripcord and power cable to the container end flap.

CLEVIS—A U-shaped metal fitting with a hole in each end to receive a pin or bolt.

CLIP—A device that fastens, holds together or retains; for example, the clip that is tacked to a riser and holds the ripcord housing in place.

CLOTH, CANOPY—The cloth used in parachute canopies. It is woven to withstand the impact of air pressure when the parachute opens. The canopy cloth is woven from nylon yarns, usually in a ripstop weave. See also **CANOPY**. (Ref. MIL-C-7020, Cloth, Nylon, Parachute.)

CLOTH, NYLON RIP-STOP—A type of nylon cloth used in canopy manufacture. The weave pattern of the nylon cloth consists of reinforced ribs, in both the warp and the filling, forming a uniform pattern of squares. The cloth is designed to keep hole damage to a minimum when rips or tears develop in the canopy.

CLOVERLEAF HANDLE—A ripcord handle that is used on chest- and integrated back-type parachutes. It is shaped in the form of a cloverleaf.

CO₂—Abbreviation for carbon dioxide.

COLLAR, VENT—A strip of nylon cloth. One edge is sewn to the vent hem of the canopy so that a collar or cylinder is formed above the top of the parachute. The other edge is hemmed to form a channel for the insertion of a molded rubber ring.

COMBUSTIBLE MATERIAL/SUBSTANCE—Any material or substance capable of burning in the presence of oxygen. See also **EXPLOSIVE MIXTURE, FLAMMABLE MATERIAL**.

COML—Abbreviation for commercial. Refers to parts that are commercially available.

COMPONENT—Item of equipment making up part of an assembly; for example, a ripcord housing is a component part of a ripcord assembly.

CONE, LOCKING—A small, smooth, cone-shaped metal post sewn to the flaps of the container or inside the vane-type pilot parachute. The cone has a horizontally drilled hole a short distance from the top to admit a temporary locking pin or the ripcord pin. The pilot parachute locking cone contains two holes. The flange contains holes for securing purposes.

CONFIGURATION—The makeup, size, shape, and relative location of parts of an item of equipment and its accessories. This includes the composition of the materials as well as marking details. The configuration of each equipment is specified by Government drawings, military specifications and modification instructions.

CONFLUENCE POINT—A coming or running together of two or more lines.

CONTAINER—An assembly that encloses and protects the canopy, suspension lines, and risers until the parachute is opened. Sometimes called the pack assembly.

CONTAINER, HARDSHELL—A container that has a rigid plastic or fiber body with cloth end and side flaps, designed to withstand high wind-blast conditions; for example, the NES-8B parachute container and certain MBEU parachute containers.

CONTRASTING COLOR—A color that stands out from its background.

CONTROLLER DROGUE—A small parachute that is used to extract the stabilizer drogue parachute.

CONVOLUTION—Used in this manual as the protruding side or portion of a diaphragm.

CORE OVERLAP—During suspension line manufacture, the insertion of an incoming core yarn that runs parallel to a running out yarn, which results in two core yarn ends protruding through the casing a distance of about 2 to 6 inches. These ends are normally cut off during final phase of parachute suspension line manufacture.

CORDS, CLOSING—Made of type I nylon cord approximately 18 inches in length. They are used as an aid in the closing of the parachute container.

CROSS BOX—A sewing pattern.

CROWN—A cloth panel used to cover the peak of a vane-type pilot parachute. Also, the portion of the main canopy surface near the peak.

CUSHION, SEAT—A square, cloth-covered pad designed to provide comfort and equipped with a slot to provide passage for the harness leg straps.

CUTTER, PYROTECHNIC—A device that is operated by an explosive charge and is used to cut line or webbing, etc.; for example, a static line cutter.

D-RING—A metal fitting shaped in the form of the letter D; for example, a D-ring on a harness connects to a chest-type parachute assembly by

means of snap fittings. Also, a slang term for the ripcord handle.

DART—A short, tapered seam.

DELAYED RELEASE JUMP—A parachute jump in which the wearer purposely does not open the parachute immediately upon safely clearing the aircraft.

DIAMETER—The greatest straight distance across a circle. Specifically, the greatest distance across a flat canopy, from skirt to skirt, measured when the canopy is lying flat. Used to designate the size of a flat canopy.

DIAMETER, NOMINAL—The diameter of a circle that has the same surface area as a given parachute canopy. This measurement is used to allow comparison of all shapes (conical, spherical, etc.) of parachute canopies.

DIAMETER, PROJECTED—The greatest distance between opposite points on the skirt hem when the canopy is inflated. The projected diameter is approximately two-thirds the diameter of a flat canopy.

DIP—A line or group of lines passing through a group of lines. Also, a group of suspension lines not in proper continuity. See also **TWIST**.

DISPOSITION—Instructions on what is to be done with or to an item.

DOUBLE-W—A sewing pattern.

DROP TEST—The release of a parachute assembly with a dummy load from an airplane, tower, or ejection seat for testing purposes.

DRY LOCKER—A tower or compartment of suitable height that will satisfactorily air fully suspended parachutes.

EJECTION SEAT—An emergency escape seat for propelling an occupant out and away from the aircraft by means of an explosive charge or rocket motor.

EJECTOR BOARD—A small, rectangular board with rounded edges and a grommet in one end used on MBEU parachutes. It serves as a firm place for the pilot parachute to spring from during opening.

ELASTOMER—Any of various elastic substances resembling rubber.

EMERGENCY KIT, PAWCHUTE—A standard soft pack, high-speed soft pack, special kit or rigid seat survival kit containing a raft and survival equipment needed by an aircrewman in case of emergency.

END OUT (MISSING END)—A warp yarn missing for a portion of, or the entire length of, cloth .

ENSURE—Make certain that necessary measures are taken.

EXAMINE—To inspect closely, and to test the condition of an item.

EXPLOSIVE MIXTURE—Any mixture of a combustible material or substance and oxygen capable of violent burning (detonation) either spontaneously or with the external application of heat.

EYE—A small, steel-wire loop; for example, the loops attached to the parachute container, into which a hook on a container spring opening band is fastened.

EYELET—A small metal reinforcement for a hole in cloth, similar to a grommet, except thinner and smaller, and having no washer. The eyelet is used to reinforce lacing holes in small covers, etc.

F—Abbreviation for Fahrenheit.

FAKE—To fold a line, rope, cord, or hawser in a back-and-forth fashion.

FASTENER, DIRECTIONAL—A snap fastener that can be engaged or released only in one direction.

FASTENER, NONDIRECTIONAL—A snap fastener that can be engaged or released by applying pressure or pull from any angle.

FASTENER, SLIDE—A type of fastener made of two lengths of tape with a series of metal or plastic scoops fastened to one side of each. A metal slide is provided that causes the scoops to mesh or lock in place as the fastener is closed, or to separate as the fastener is opened. Colloquial usage **ZIPPER**.

FELT—A cloth made from wool, fur, hair, synthetic fiber, or a mixture of these with cotton. It is made by matting the fibers together under pressure and heat.

FERRULE—A cap or ring used to finish the end of a housing; for example, the finished ends of a ripcord housing.

FIBER—A natural or synthetic filament (as of wool, cotton, rayon, etc.) capable of being spun into yarn.

FID—A small, flat hand tool of metal or wood used during the packing process to straighten end flaps and to insert corner flaps into a finished pack.

FILLING—Threads that are perpendicular to selvage edges, and extend across the width of cloth .

FITTING ASSEMBLY, DISCONNECT—A releasing device used on the LW-3B parachute assembly, which detaches both the static line and the ripcord assembly from the container side panel after either has effected opening of the container.

FITTING, CANOPY QUICK-RELEASE—A device that connects the canopy and risers to the harness, permitting the aircrewman to disengage himself, on instant response, from the canopy.

FITTING, OVERRIDE DISCONNECT—A directional fitting used on the NB-11, NES-12, and NES-16 parachute assemblies that connects the external pilot parachute and the pilot parachute.

FITTING, QUICK-RELEASE—A device used to connect and release on instant response. See also **FITTING, CANOPY QUICK-RELEASE**.

FITTING, SWAGE—A connection, adapter, or pin that is fastened to a cable by pressure. It is applied by means of a machine that compresses the fitting, causing it to tightly grip the cable or wire to which it is being attached.

FLAMMABLE MATERIAL—Any material capable of being easily ignited and of burning with extreme rapidity.

FLAP, CORNER—One of the small, rectangular cloth tabs that are part of the container side flaps and act as protection and reinforcement of the container corners when the parachute is packed.

FLAP, END—A cloth extension on the short sides of the container base that folds over to enclose the canopy. One of the end flaps is usually designed as the ripcord end flap.

FLAP, SIDE—A cloth extension on each of the long sides of the container base, which folds over and encloses the canopy. Each side flap is designated according to the fittings it carries; for example, locking cone side flaps or grommet side flap.

FLARING—The process of opening or widening; for example, the method of splitting, taping, and stitching the ends of webbing in order to widen and prevent it from slipping through an adapter.

FLOAT, MULTIPLE—A place in cloth where a series of floats extend 3/16 inch or more.

FLOAT, SINGLE—A place in cloth where a filling or warp yarn extends unbound over the pick(s) with which it should be interlaced.

FOLDER—A device used as an attachment to a sewing machine to guide and fold cloth.

FRAME, CONTAINER—The framework used to stiffen and hold the container in shape.

FRAYED (SUSPENSION LINE)—A fuzzy condition in which short lengths or pieces of thread or yarn protrude from surface of suspension line.

FREEZING POINT—Temperature at which a given liquid substance will solidify or freeze upon removal of heat. Freezing point of water is 32°F (0°C).

FULL—In reference to oxygen cylinders, a full oxygen cylinder is a cylinder that is pressurized to its rated pressure. With respect to a high-pressure oxygen cylinder, 1800 psig is considered full.

FUNCTIONAL TEST—A test that puts an item to use to determine if it operates properly.

GAPL—Abbreviation for Group Assembly Parts List. The GAPL, a section of the Illustrated Parts Breakdown, shows how major assemblies are disassembled into assemblies and detail parts.

GORE—That portion of the canopy located between two adjacent radial seams and the vent and skirt hem. It consists of cloth sections sewn together.

GROMMET—A metal eye and washer used to reinforce a hole in material; for example, grommets on container side flaps.

H₂O—Abbreviation for water.

HANDLE, RIPCORD—The handle secured to the ripcord cable and retained in a pocket located on the harness or container. Pulling of the handle begins the process of parachute opening. Often referred to as hand-pull or grip.

HARNESS—An arrangement of webbing straps used to attach a parachute to the aircrewman. The harness serves as a sling to support the aircrewman during descent.

HARNESS, CHEST-TYPE—A harness assembly used with attachable, chest-type parachute.

HARNESS, MAIN SLING—The main load-carrying member of the harness. Formed by two lengths of webbing, it is routed from the shoulder adapters or D-rings down across the seat, up the side ending at the opposite adapters or D-rings.

HEAT EXCHANGER—Apparatus in which heat is exchanged from one fluid to another.

HEAVY BAR OR PLACE—An area on cloth where pick count varies from normal count. See also PICK.

HEM—A border or reinforced edge formed by folding cloth back and securing it, usually by sewing; for example, vent and skirt hem of a parachute canopy.

Hg—Abbreviation for mercury.

HOLE, CLOTH DAMAGE—Three or more warp and/or filling threads broken at the same location.

HOOK, PACKING—A special hook used to draw suspension lines into place in hesitater loops.

HOOK, TENSION—Hooks used to retain the connector links during parts of the packing procedure.

HOUSING, EXTENSIBLE RIPCORD—A ripcord and housing that can be extended approximately 4 inches to accommodate the addition of a raft kit to the seat-type parachute assembly.

HOUSING, RIPCORD—A flexible steel tube encasing the ripcord cable used to protect against accidental release of damage and to serve as a cable guide. Integrated ripcord assembly housings are constructed of vinyl-coated flexible tubing.

IN.—Abbreviation for inches.

IND—Abbreviation for indicated.

IN. H₂O—Abbreviation for inches of water column (27.68 in. H₂O equals 1.0 psi equals 2.036 in. Hg). See also **IN. Hg**.

IN. Hg—Abbreviation for inches of mercury column. (0.07349 in. Hg equals 1.0 in. H₂O) See also **IN. H₂O**.

INNER CORE—Five to nine internal yarns (number depending on type) for suspension lines that are covered by a woven sleeve or casing.

INSPECTION—A close examination for damage, wear, and dirt. Also, regularly scheduled examination of parachute assemblies. See also **SERVICING PARACHUTES**.

KEEPER—Small strip of tape or loop used to retain an object; for example, riser and back pad keepers.

KIAS—Knots indicated air speed.

KICKPLATE—A platform on the NES-8B parachute container that serves as a firm place for the pilot parachute to spring from during opening.

KIT BAG, FLYER'S—A container made of canvas or nylon and reinforced with webbing, usually with a slide fastener opening. It is used to carry the parachute and its accessories.

KNOT, BINDER—The simplest method of joining two threads or lines. The two ends are placed side by side and a simple, overhand knot is then tied in both lines simultaneously. It will not slip when drawn tightly. Also called a thumb knot.

KNOT, BOWLINE—A knot formed by making a small overhand loop a desired distance from the end of the line. The end of the line is then passed through the loop from the underside of the main part of the line and back through the small loop. When this knot is drawn tight, it will not slip but still can be easily untied.

KNOT, CLOVE-HITCH—A knot formed by making one turn around a post, bringing the end across the line, continuing around the post a second time, and passing the end under the second loop. Used to tie suspension lines to connector links.

KNOT, HALF-HITCH—A knot formed by passing a cord or line around an object, then passing the free end around the main part of the cord and bringing the free end up through the loop thus formed. It is used to finish the tying of the suspension lines to the connector link and in forming safety ties.

KNOT, LARK'S HEAD—A knot formed around an attachment ring or bar by passing the free ends of the line around the bar or through the ring and then through a loop or bight in the line. This knot is used to attach pilot parachute connector straps.

KNOT, OVERHAND—A simple knot tied in the end of a line by forming a loop and passing the end over and down through the loop.

KNOT, SQUARE—A knot formed by passing the end of the cord in the left hand over and under the end in the right hand, and then reversing the process by passing the end in the right hand over and under the one in the left hand.

KNOT, SURGEON'S—The surgeon's knot is similar to the square knot, except that the first overhand tie is wrapped twice around the cord or line.

LB—Abbreviation for pounds.

LIFT WEBS—The parts of parachute harness webbing or riser that extends from the connector

links to the shoulder adapters, D-rings, or quick-release fitting.

LINE, ANTI-SQUID—A line attaching two suspension line connector links to canopy vent lines on some parachute assemblies. The anti-squid lines are shorter than suspension lines and prevent the main canopy from squidding by bearing the load of the drogue parachute until the main canopy is fully opened. See also **SQUIDDING**.

LINE, DROGUE LINK—A line connecting the withdrawal line to the drogue parachute on MBEU systems that do not employ a guillotine. The drogue link line contains a slide disconnect pin, which will separate the line and withdrawal line in case of manual parachute actuation.

LINE, SHORT ANTI-SQUID—A Martin-Baker patent improved anti-squid line, also called a pull down vent line. See **LINE, ANTI-SQUID**.

LINE, STATIC—A line used to open a parachute assembly without the necessity of pulling a ripcord manually. A static line is attached to the ripcord manually. A static line is attached to the ripcord and the aircraft or ejection seat. When the line becomes taut, it withdraws the ripcord locking pins or deployment bag. The parachute then opens.

LINE, SUSPENSION—Nylon cords that connect the canopy of the parachute to the harness assembly.

LINE, TOGGLE—One or more parachute lines that run from a slot or orifice in a steerable canopy to the harness, providing steerability. When such lines are under tension during parachute opening or descent, they are classified as suspension lines.

LINE, VENT—Nylon cord that crosses the vent opening of a canopy.

LINE, WITHDRAWAL—A line connecting the stabilizer drogue on the ejection seat to the locking pins and canopy vent on the NES-8B and MBEU parachute assemblies. The line opens the container and withdraws the canopy during normal ejection operation.

LINE, CONNECTOR—A small, releasable, rectangular metal fitting used to connect the lift webs and suspension lines.

LINK, CONNECTOR, WITHDRAWAL LINE—Nylon webbing with loops sewn in both ends. The withdrawal line connector link attaches the withdrawal line to the apex of the canopy and large loop in shortened anti-squid line.

LOCK, RIPCORD PIN—The ripcord pin lock is used in conjunction with the ripcord pin pull test. The lock is designed in such a manner as to allow initial movement of the ripcord pins, but does not permit them to totally disengage.

LOCKSTITCH—A common sewing-machine stitch formed when the thread in the needle goes through the material and connects with the bobbin thread. The needle and bobbin thread should lock in the center of the material thickness. (Reference Federal Standard 751, Type 301.)

LONG BAR—A long metallic or wooden bar used in parachute packing and used as an aid in closing a parachute container.

LOOP—A warp or filling thread pulled out to form a loop on a cloth surface.

LOOP, HESITATOR—One of a series of webbing or tape loops that holds suspension lines in an orderly position in the container when the parachute is packed, and that pays the lines out in sequence for orderly deployment of the canopy assembly.

LOOP, LOCKING—A loop sewn to deployment bag or canopy to allow full extension of suspension lines before opening the canopy.

LOOP, RETAINING—Webbing or tape loop used to hold folded lines or excess webbing in position.

LOOSE STITCHES—Thread that does not lie smoothly on the surface of the cloth.

LOX—Abbreviation for liquid oxygen.

LPM—Abbreviation for liters per minute.

LUMP—An internal imperfection of a suspension line that feels hard to the touch. It is usually caused by internal knots in core yams or casings, or by slippage or displacement of one or more inner core yams near an overlap.

MANUFACTURERS' CODES—Identification codes for every manufacturer listed as

a procurement source in accordance with cataloging handbooks H4-1 and H4-2, Federal Supply Codes for Manufacturers.

MARGIN—The space from the outer row of stitching to the edge of the fold of cloth.

MILDEW—A damaging fungus or mold that forms on cloth and leather. It is caused by dampness and the absence of fresh air and sunlight.

MIS-PICK—An extra or incorrectly positioned filling thread.

MISSING PICK—A filling yarn (pick) wholly or partially missing.

MISSING STITCHES—A space between stitches in the same row in which there is no thread.

MM—Abbreviation for millimeters.

NAMEPLATE—A label attached to equipment, giving data as to type, model number, date of manufacture, date placed in service, etc. The stenciled gore on a canopy is called the nameplate gore.

NEEDLE DAMAGE—Where needle penetration has damaged threads in the cloth.

NOTE—An informative item. The note may precede or follow the step or item to which it refers.

OVEREDGE—Stitching around the outer edge of cloth to prevent the edges from raveling or fraying.

OVERFOLD—An excess of material causing edge of inner fold to double, wrinkle or pleat.

OVERLAP—To extend over and cover a piece of cloth.

OVERLAP, CORE—The overlapping of an incoming and outgoing suspension line inner core line.

PACK—To put together compactly; to store neatly; for example, the act of packing a parachute consists of stowing suspension lines and canopy in the container assembly in such a way

as to ensure safe storage and proper opening of the parachute assembly.

PACK ASSEMBLY—A rigged and packed parachute. See also **CONTAINER**.

PACKING BOARD—A tool used to tension suspension lines with the anti-squid lines attached to the connector links. Basically it consists of a board and two large spools.

PACKING TRAY—The suspension line stowage assembly on the NES-8B parachute assembly. It is a cloth-covered board with hesitater tubes attached. After stowage of suspension lines, the container is moved up around the tray. The tray is then secured by bolts, which pass through the bottom of the container.

PAD, BACK—A pad attached to the inside of the parachute harness to provide comfort.

PALM, SEWING—A hand protector that is used when sewing.

PANEL, END SCOOP—A scoop-shaped cloth pocket attached to the bottom of the LW-3B parachute assembly in place of an end flap.

PARACHUTE—A device that offers resistance to the air, thereby decreasing the velocity of a descending body to permit landing at a suitable rate of descent.

PARACHUTE ASSEMBLY—A complete parachute, including the canopy assembly, container assembly, harness assembly, and riser/lift web assembly.

PARACHUTE, ATTACHED-TYPE—A parachute assembly, such as T-10 or NES-15A, that has its container opening device attached to the aircraft or ejection seat by a static line.

PARACHUTE, BACK-TYPE—A parachute that is worn on the back to allow the wearer freedom of movement; for example, the NB-6 parachute assembly.

PARACHUTE, CARGO—A parachute used to air drop materials such as food, water, explosives, clothing, weapons, and supplies.

PARACHUTE, CHEST-TYPE—A parachute that is attached to D-rings on the chest-type

harness. It may be detached to permit more freedom of movement.

PARACHUTE, DROGUE—An auxiliary parachute used with any system that requires some method of deceleration or stabilization; for example, an ejection seat.

PARACHUTE, FREE-TYPE—A parachute assembly, such as NS-3, that is opened by manual or automatic pulling of a ripcord. No static line is used with this type of parachute assembly.

PARACHUTE, PILOT—A small, spring-operated, cloth-covered auxiliary parachute that is usually constructed on a steel wire frame and attached to the peak of the canopy. It accelerates the withdrawal of the canopy from the container. The pilot parachute is packed under tension and immediately opens when released from the container.

PARACHUTE, RESERVE—A chest-type parachute attached to the harness of a training or test parachute in addition to the back type. It has no pilot parachute. It is used in case the main parachute fails to open properly or sustains such damage as to cause an unsafe rate of descent.

PARACHUTE SEAT-TYPE—A free-type parachute suspended at the rear of the wearer between the hips and knees. It has an attached seat pad, together with the container, that serves as a cushion when the entire assembly is in place in the seat.

PARACHUTE, TRAINING—A combination of two parachute assemblies. A main, back-type parachute and reserve, chest-type parachute, with a training harness assembly designed to accommodate both parachutes. Its use is mandatory on all premeditated student training jumps.

PARACHUTE, TROOP—A parachute used by a paratrooper for a premeditated jump over a designated area.

PARACHUTIST, NAVAL—A person who has successfully completed a prescribed course in parachute jump training.

PARAFFIN—Wax generally used with 50-percent beeswax as a hot dip to prevent the fraying of cut ends of webbing, cord, and tape. See also **BEESWAX**.

PARARAFT—An emergency, one-man life raft packed in a container, along with survival equipment. The pararaft is secured to the parachute pack or seat pan.

PARATROOPER—A soldier trained and equipped to parachute into combat.

PEAK—The top center of the parachute canopy, the point at which all vent lines cross. Also called apex or crown.

PERMEABILITY—The measured amount, in cubic feet, of the flow of air through a square foot of cloth in 1 minute under a specified pressure.

pH VALUE—An indication of the acidity or alkalinity of a solution. A reading of pH may be made by the use of test strips.

PICK—A cloth filling thread, taken as a unit of fineness of cloth.

PILOT PARACHUTE FRAME—Wire frame or spring used in a type of pilot parachute to initiate opening action of a parachute upon release from the container.

PIN, RIPCORD LOCKING—A small steel pin attached to a ripcord and passed through a locking cone to hold a container in a closed position.

PIN, SLIDE DISCONNECT—A directional fastener that connects the withdrawal line and drogue link line on MBEU parachutes not designed for use with a guillotine. One portion connects to the ejection seat and the other is a metal sleeve around the drogue link line. Depending on the direction of pull, the lines will either remain attached or the slide disconnect pin will be withdrawn, and the lines will separate.

PIN, TEMPORARY LOCKING—A metal pin inserted through the eye of the locking cones to hold the side flaps in place until the ripcord pin is inserted.

PLATE, ANCHOR—A narrow metal plate used on MBEU parachute assemblies. It is attached to the end of the ripcord housing and has holes that fit over the container locking cones. When the ripcord pins are inserted in the locking cones, the anchor plate is held in place, thus holding the ripcord housing in position.

PLATE, LOCKING PINS—A temporary locking pin attached to a thin, flat, rectangular metal plate. The pin-plate arrangement is used to temporarily lock the pilot parachute while the side flaps are being closed.

PLEAT—A fold sewn in cloth.

POCKET, DATA CARD—Small patch pocket sewn to specified parachute containers for record data card. (Record card used for drogue parachute assemblies only.)

POCKET, ELASTIC STOWAGE—A pocket, formed of elastic cloth, that encloses the external pilot parachute on the NB-11 parachute assembly.

POCKET, RIB—A pocket made by sewing lengths of tape to a type of pilot parachute canopy to contain the four frame ribs.

POCKET, RIPCORDER HANDLE—A small pocket of cloth or elastic webbing sewn to the harness (or container assembly). It holds the ripcord handle in position.

POCKETS, DEFLATION—Pockets sewn to the canopy at the skirt hem. After landing in water, they serve to anchor the canopy, causing the canopy to deflate. This prevents the canopy from dragging the parachutist through water.

POROSITY OF A FABRIC—The measured amount, in cubic feet, of the flow of air through a square foot of fabric in 1 minute under specified pressure. Also known as **PERMEABILITY**.

PREMATURE OPENING—Any accidental opening of a parachute that occurs prior to intended deployment.

PRESSURE—The force exerted by liquid or gas per unit of area on the walls of a container. See also **PSIG**, **PSIA**, and **ATMOSPHERIC PRESSURE**.

PRESSURE DROP—Loss in pressure, as from one end of a distribution line to the other, due to friction and other factors.

PRESSURE EXPLOSION—Explosion caused by rapid conversion of liquid oxygen to gaseous oxygen in a confined space due to evaporation and warming.

PROTRUDING YARN (Core Casing or Tread)—A condition in which either the inner core yarns extend through the casing or where the yarns or threads of the casing extend beyond the surface of the casing itself.

PSI—Abbreviation for pounds per square inch. See also **PSIA** and **PSIG**.

PSIA—Abbreviation for pounds per square inch, absolute. Absolute pressure is measured from absolute zero (100-percent vacuum) rather than from normal, or atmospheric pressure. It equals gauge pressure plus 14,696 pounds per square inch. See also **PSI**, **PSIG**, and **ATMOSPHERIC PRESSURE**.

PSIG—Abbreviation for pounds per square inch, gauge. Indicates pressure above ambient pressure, as indicated on a pressure gauge vented to the atmosphere. See also **PSI** and **PSIA**.

PULL UP CORDS—Nylon cords of varying lengths used to pull up the sides and ends of the container flaps over the container cover and to pull the cones through the grommets. They are also used to pull the suspension lines into place in some types of containers.

PUSHPIN—A straight pin used to temporarily secure material while sewing.

PYRO BOX—The container used to store pyrotechnic devices such as flares and cartridges while they are removed from the ammunition storage area.

PYROTECHNIC DEVICE—Any device that either burns or explodes or uses burning or exploding to operate a system. Examples of pyrotechnic devices are static line cutters, ballistic spreading guns, and automatic actuators.

QA—Abbreviation for quality assurance.

QUALIFIED PERSONNEL—Qualified personnel are defined as personnel who have satisfactorily completed a prescribed course at a Navy training school, Fleet Readiness Aviation Maintenance Personnel Training Program (FRAMP), Interservice/factory training, or formal or informal in-service training [refer to OPNAVINST 4790.2 (series)]. In addition, a practical demonstration of the skills acquired in any of the foregoing training situations, to the

satisfaction of the work center supervisor/division officer, is required before the designation "qualified" can be assigned.

R—Abbreviation for radius.

RATE OF DESCENT—The speed that a parachute descends through the air. The rate varies according to atmospheric pressure, weight of load, movement of air (updraft and downdraft), and size, design, and condition of canopy.

RAVEL (UNRAVEL)—TO separate, untwist or unwind, leaving a frayed or ragged edge. Ravel is the preferred word to describe such a condition.

RECEIVER ASSEMBLY, AUTOMATIC PARACHUTE RIPCORDER RELEASE—That part of the cartridge-actuated automatic ripcord release that houses the aneroid, sear, and hammer.

REF—Abbreviation for reference.

REFILL (In reference to oxygen cylinders)—To refill is to recharge a cylinder, regardless of the residual pressure remaining within the cylinder.

REINFORCEMENT—Any strengthening measure that enhances the basic integrity of a structure, joint or assembly; for example, the tape or webbing used to strengthen parts of a canopy, container, harness, etc., in a parachute assembly. See also WEBBING and REINFORCEMENT.

RELEASE ASSEMBLY, RIPCORDER HOUSING, MANUAL—An assembly that releases the ripcord housing at the top end flap when the parachute is at full suspension line stretch.

REPAIRS, MAJOR—Repairs requiring special equipment, personnel, or materials normally not available at intermediate or local levels of maintenance.

REPAIRS, MINOR—Repairs that can be effected at intermediate or local levels of maintenance.

RETAINING SLEEVE—A series of stowage tunnels.

RFI—Ready for issue.

RIG—To assemble and adjust; to equip. For example, the act of rigging a parachute assembly consists of assembling all component parts in preparation for packing.

RING, VENT—A molded rubber ring in the vent collar. It stretches when the air rushes into the canopy as the parachute begins to inflate.

RIPCORDER—A locking device that secures the folded parachute within the container and that effects the release of the parachute. The ripcord consists basically of locking pins, a flexible cable and a handle. See also AUTOMATIC PARACHUTE RIPCORDER RELEASE; BALL, CABLE RETAINING; CABLE, RIPCORDER; CLAMP, RIPCORDER HOUSING; HANDLE, RIPCORDER; HOUSING, EXTENSIBLE RIPCORDER; HOUSING, RIPCORDER; IN, RIPCORDER LOCKING; POCKET, and RIPCORDER HANDLE.

RIPCORDER PIN RETENTION TIE—A thread of a predetermined value that is usually secured to a lead ripcord pin of a packed parachute. Its function is to retain a ripcord pin in its cone and prevent premature disengagement of the pin from the cone. USE ONLY AS AUTHORIZED.

RISER—The webbing that connects an integrated torso suit or harness to the canopy assembly on parachutes. The riser is composed of two lift webs, and there are two risers on each parachute assembly.

RUNOFF—Sewing not on a seam or cloth.

RUPTURE—One or more yarns of suspension line casing being cut or severed, sometimes exposing the inner core. Occasionally, tears, cuts, or other forms of damage to the canopy are defined as a rupture when caused by dynamic load conditions.

SADDLE—That part of the main lift web of the harness that provides a seat or sling for the wearer.

SAFETY TIE—A low strength thread that serves to indicate that an assembly has not been damaged, tampered with, or opened since the last regular inspection.

SCRAP—To discard, with proper authorization, items, parts or materials that are obsolete or no longer usable.

SDLM—Standard depot-level maintenance. Provides for a comprehensive inspection of selected aircraft structures and materials, critical defect correction, preventive maintenance as required, modification and technical directive compliance to ensure reliability and operational availability of the aircraft at minimum cost for the established operating service period, and to provide intermediate support during the total service life.

SDLM/CONVERSION—Standard depot-level rework concurrent with special rework, the accomplishment of which alters the basic characteristics of the aircraft to such an extent as to effect a change in any part of the model designation (i.e., F-4B to F-4D). NAVAIR approval required.

SDLM/CRASH DAMAGE—In addition to accomplishing SDLM (standard depot-level maintenance), repair and restoration to a serviceable condition that part of the aircraft that has sustained damage resulting from an accident or an incident.

SDLM/MODIFICATION—Accomplishment of standard depot-level rework concurrent with a modification that causes major work effort resulting from the installation of these technical directives. NAVAIR approval required.

SEAM—A series of stitches joining two or more pieces of cloth. For government work, the type of seam is indicated by a symbol that gives the class of seam, the number of stitching, and the number of rows of stitching. (Reference Fed. Std. 751.)

SEAM, DIAGONAL—A French-fell seam of the canopy that joins two sections of a gore. Diagonal seams meet the centerline of the gore at angles of 45° and 135°.

SEAM, ENGLISH-FELL—A seam in which one piece of cloth is folded back upon itself, and the other piece is a plain overlap.

SEAM, FOUR-NEEDLE FOUR-STITCH—A method of stitching that can be performed in one operation by a four-needle sewing machine.

It is used in sewing the vent hem, skirt hem, and radial seams of a canopy.

SEAM, FRENCH-FELL—A seam in which the cloth is folded back upon itself and stitched.

SEAM, OVERLAP—A seam in which the two pieces of cloth are joined by overlapping enough to accommodate one or more rows of stitching.

SEAM, RADIAL—A seam, joining two gores, that extends radially from the vent to the skirt hem.

SEAM, TWO-NEEDLE TWO-STITCH—A seam in one operation by a two-needle sewing machine; for example, a diagonal seam.

SEAR—To melt or seal with heat; for example, to sear the end of nylon webbing, one heats the end until the nylon melts and fuses. This prevents raveling. Also, the catch that holds the hammer of a firing mechanism cocked. The sear in an automatic parachute ripcord release is attached to the aneroid in the receiver assembly.

SEAT PAN—A sponge-rubber-covered metal seat that is contoured for comfort to the user. A seat pan is used with seat-type parachutes and back-type parachutes when a packaged life raft assembly is used. A high-speed seat pan has sections for support under the pilot's thighs during ejection. This reduces leg strain caused by high acceleration loads.

SECTION—Each major part of a gore. Sections are bordered by radial seams, diagonal seams, or vent or skirt hems. In the 28-foot, flat canopy, four sections are used in each gore (previously known as panel).

SECURITY—An item firmly, positively, and safely attached in the authorized manner.

SELVAGE—An edge of a woven fabric so formed as to prevent raveling, as compared to a cut edge, which will ravel.

SELVAGE, BROKEN—Cut, broken, or torn selvage edge.

SELVAGE, STRINGY OR LOOPY—Irregular stringy or loopy selvage edge.

SEPARATOR, SUSPENSION LINE—A tool used to aid in keeping suspension lines and canopy skirt in order while packing a parachute.

SERVICE LIFE—The time period during which the item can be maintained in service without replacement.

SERVICING PARACHUTES—Inspecting, cleaning, repairing, and repacking parachutes at periodic (calendar) intervals. Periodic intervals for parachutes should correspond either to the aircraft calendar inspection or to the phased maintenance inspection cycle program, as directed by applicable MRC or Special Inspection Card Deck.

SERVING—A method of wrapping or binding the ends of a cord or a line so it will not ravel. Sometimes referred to as “whipping.”

SEWING MACHINE—A machine with a power-driven needle, used for sewing and stitching.

SHEARS, PINKING—Shears with a saw-toothed inner edge on the blades for making zigzag cut.

SHROUD LINE—Slang for suspension line.

SKIPPED STITCHES—Threads that are not interlocked.

SKIRT, CANOPY—The lower edge of a canopy.

SLMIP—Suspension line mandatory inspection point.

SLUB—An abruptly thickened place in cloth caused by manufacturer’s defect.

SM&R CODES—Abbreviation for source, maintenance, and recoverability codes. Comprised of three parts; a two—position source code, a two—position maintenance code, and a one—position recoverability code.

SMASH—Abrasion damage that causes broken warp and filling threads and weave separation.

SNAP, QUICK-CONNECTOR—A large, hook-shaped, spring-loaded snap used to attach the chest-type parachute to the two D-rings on the harness.

SNAP, QUICK-EJECTOR—A harness snap that attaches to the V-ring to secure two parts of the harness together. The ejector arm releases the V-ring when the finger-grip lever is pulled out ward.

SOCKET, AUTOMATIC PARACHUTE RIPCORDER RELEASE—The part of the automatic parachute ripcord release that engages the ball on the power cable. This socket is attached to the piston by a rivet.

SPECIFIC GRAVITY—Density of fluid compared to density of water.

SPEED LINK—Slang for connector link.

SPLICE—The joining of two strands for core ends by interweaving or mechanical joint.

SPREADER BAR—A type of tension hook, used to hold connector links in position during parts of the packing procedure.

SPREADING GUN, BALLISTIC—A device attached to suspension lines just below the skirt hem on the parachute assembly. Just before full suspension line stretch, the gun discharges and, by explosive force, spreads the skirt of the canopy.

SPRING, CONTAINER OPENING BANDS—Stretchable bands composed of a series of springs installed in a cloth case with a hook at each end. They are installed under tension on the pack, to pull apart the end and side flaps after the ripcord is pulled. Also called pack opening band or bungee.

SQUIDDING—A state of incomplete canopy inflation in which the canopy has a squid- or pear-like shape.

STAND, CONTAINER—A rigid stand used to hold some parachute containers, such as the Martin-Baker horseshoe container, during part of the packing procedure.

STATIC LINE CUTTER—A device used to cut the static line to free the parachutist and prevent entanglement.

STIFFENER, CONTAINER—A piece of metal or fiber glass or phenolic fiber placed in the container to stiffen the flaps. These strips are also used for stiffening and shaping the bottoms of several back-type containers.

STITCH, BASEBALL—A stitch used in repair and patching of fabrics. Refer to “Repair/Fabrication,” Chapter 4, of NAVAIR 13-1-6.2

STITCH, BASTING—A long, loose stitch made with single or double thread. Used to temporarily hold two or more pieces of material.

STITCH, BOX—Rectangular stitch used to attach and reinforce.

STITCH, BUTTONHOLE—A reinforced stitch made on the edge of a slit or hole. Each individual stitch forms a half-hitch. The distance from the edge, and the spacing of the stitches, is determined by the type of material used.

STITCH, OVERTHROW—A stitch used to repair weakened seams, to reinforce slide fasteners, and to join two pieces of material together.

STITCH, ZIGZAG—A stitch made by a sewing machine that stitches alternately on two or more parallel lines; for example, it is used to reinforce and anchor the suspension lines to the canopy. The number of stitches per inch is determined by counting the number of points on one side per linear inch.

STITCHES PER INCH—The number of needle penetrations where threads are interlaced, per linear inch.

STRIP BACK—Broken thread filament(s) wrapped around the remaining thread forming an enlarged area on cloth.

STRAP, CHEST—The harness webbing that is secured across the chest with a snap and a V-ring to prevent the wearer from falling out of the harness.

STRAP, CROSS CONNECTOR—A short length of webbing sewn across the lift web assembly or attached between suspension line connector links. It prevents streaming of a canopy in the event one riser was not properly attached to the harness.

STRAP, HORIZONTAL BACK—An adjustable part of harness webbing extending across the small of the wearer’s back.

STRAP, LAP RESTRAINT—A strap attached to the integrated torso harness suit to retain the rigid seat survival kit to the wearer. Prior to ejection it serves as safety restraint for the aircrewman.

STRAP, LEG—That part of the harness webbing that encircles the wearer’s leg. The leg straps are adjustable.

STRAP, PILOT PARACHUTE CONNECTOR—Tubular nylon webbing that joins the main parachute and the pilot parachute.

STRAP, SHOULDER—The part of the harness webbing that crosses the wearer’s back at the shoulder blades.

STRAP, TENSION—A strap that attaches to the peak of a canopy to keep the canopy and suspension lines taut during parts of the packing procedures.

STOWING—The act of putting away in a neat, orderly way. Stowing of suspension lines involves inserting the lines into the hesitator loops or stowage channels in such a way as to ensure proper paying out of lines when the parachute is opened. Stowing of the canopy involves folding and inserting the canopy into the container in such a way as to ensure proper opening of the canopy when the parachute is used.

SUPPORT FIXTURE—A rectangular piece of metal used to aid in closing the LW-3B personnel parachute assembly. The fixture is bolted to the container base and clamped to the packing table.

SURVEY—A formal process by which a parachute or other accountable equipment is withdrawn from service or removed from records.

SWAGE—To attach a device to a cable by means of pressure. A swaging machine compresses a fitting, causing it to grip tightly to the cable to which it is being attached.

T-HANDLE—A handle in the shape of the letter *T*.

TAB, ANCHOR—A cloth loop attached to a metal plate and used on some MBEU parachute assemblies. It is placed over a locking cone and is used to secure the withdrawal

line slide disconnect pin in position prior to operation.

TAB, END—An oval metal fitting secured to each flap of seat-type, Martin-Baker and chest-type parachute containers. The end tabs fit over the cones and secure the end flaps in a closed position until the locking pins are pulled.

TACK (HAND TACK)—To attach temporarily prior to final sewing and to tie temporarily as an aid in positioning. Also, to permanently secure portions of a parachute together; for example, the attachment of a seat cushion to a parachute container assembly.

TACK, BUTTERFLY—The type of tacking used in securing the riser assembly to the NC-3 container. See also **TACK**.

TAPE—A narrow woven ribbon of cotton, linen, nylon, or other material.

TAPE, FILAMENT—An adhesive tape with fiber cords in the backing. The cords are usually fiber glass, nylon, linen, or other high-strength material. This tape has high tensile strength along the lengthwise direction.

TAPE, HOOK—Strip of nylon tape with small nylon hooks on one side. Hook tape is used with pile tape as a fastener.

TAPE, PILE—A strip of nylon tape with small nylon loops on one side. Pile tape is used with hook tape as a fastener.

TAPE, SURGICAL—A white linen or cotton tape with adhesive on one side. Commonly called adhesive tape.

TEAR STRENGTH—The average force, expressed pounds, required to continue a tear either across the filling or warp of cloth.

TEMPLATE—A pattern or gauge commonly in the form of a thin plate of cardboard, wood, or metal. It is used as a guide in the layout or cutting of flat work.

TENSILE STRENGTH—The greatest stress cloth can withstand along its length without rupturing, expressed as a number of pounds per square inch (of cross section).

TERMINAL END FITTING—The end of the automatic parachute ripcord release arming cable that connects to the ejection seat, lap belt, or other designated point. See also **CABLE**, **ARMING**, and **AUTOMATIC PARACHUTE RIPCORD RELEASE**.

THIN SPOT (Suspension Line)—A condition whereby the diameter of the suspension line as seen visually is less than other portions of the suspension line. This condition is normally caused by broken inner cord yarn(s) or an improper overlap.

THREAD, SEPARATION—A bunching of threads in cloth, leaving a hole or separation in the cloth. A thread separation can run either with the warp or filling of a cloth.

TIE, RIPCORD PIN RETAINING—A low-strength thread or cord used specifically to prevent ripcord pins from creeping and possibly causing inadvertent opening.

TIGHT STITCHES—Thread under excess tension, causing one sewing thread to lie on the surface of the cloth or causing puckering of the cloth.

TOOL, PACK CLOSING—An aid to closing the LW-3B parachute assembly container. It is used to align the grommets over locking cones.

TORSO HARNESS SUIT—A combination of webbing and a torso suit that includes the parachute harness, lap belt, shoulder belt, and life vest attachment fittings. See also **HARNESS**.

TORQUE—A force or combination of forces that tend to produce a rotating or twisting motion. Torque is often expressed in inch-pounds or foot-pounds. A torque wrench is used to apply a measured torque.

TOTAL LIFE—Total life is the period of time commencing with the date of manufacture that an item may be retained in a packaged, out-of-service condition and remain acceptable for service.

TUBE, GUIDE—A narrow tube used to guide the vane-type pilot parachute grommet over its locking cone.

TWIST—Rotation of the suspension line casing induced generally during final assembly of the canopy, suspension lines and connector links.

TWIST OF THREAD OR CORD—The direction (right or left) in which the strands of thread or cord are wound around one another. If the thread unwinds when turning it to the left, it is right twist; if it tightens, it is left twist. Right twist is also known as Z-twist. Left twist is also known as S-twist.

TYP—Abbreviation for typical.

UNDERFOLD—Insufficient cloth folded inside a seam. The raw edges of cloth will show when underfold is excessive.

UNEVEN STITCHING—Stitching wavy, or number or stitches varying.

UNTACK—To remove a tacking. See also **TACKING**.

V-RING—A metal fitting shaped in the form of a closed letter *V*. For example, V-rings, used with quick-ejector snap fittings, secure a harness assembly on a wearer.

V-TAB—Webbing reinforcement at the point where the suspension line enters the canopy.

VENT—The circular opening at the peak or top of the canopy. As the parachute opens and descends, some of the air in the canopy escapes through this vent, thus reducing the strain on the canopy and steadying descent. It is about 18 inches in diameter for personnel parachutes.

WARNING—Indicates danger to personnel. The warning precedes the step or item to which it refers.

WARNING FLAG—A tag attached to an assembly, indicating that the assembly is not operational. Often the flag is attached to safety-pins on pyrotechnic devices to indicate necessity of removal before operation. Also, it is

used to flag defective or incomplete equipment to preclude use.

WARP—The threads that run parallel to the selvage edge of cloth; those that are crossed by the filling threads.

WEAVE—To manufacture a web or cloth on a loom by interlacing the warp and filling yams. Also the particular pattern employed in weaving cloth. The cloth for parachute use is one up and one down (plain weave), two up and one down (twill weave) or ripcord.

WEAVE SEPARATION—Looseness of weave caused by strain or poor weaving.

WEB (WEBBING)—A strong, narrow, closely-woven tape of synthetic, cotton, or linen fiber designed for bearing weight. For example, it is used in the manufacture of the parachute harness.

WEBBING, ELASTIC—A webbing having elastic threads to give it greater elasticity than regular webbing. It is used in the fabrication or elastic ripcord pockets.

WEBBING, REINFORCEMENT—Short lengths of webbing sewn to the skirt hem at the junction points of the suspension lines and the canopy.

WEBBING, TUBULAR—Strong synthetic or natural fiber webbing woven in the form of a tube.

WET LOCKER—A tower or compartment maintained for hanging parachutes that are damp or have been immersed in water.

WHIPSTITCH—A stitch used to join two piece of webbing and to reinforce weak seams.

WHISKER—A thread filament protruding from cloth.

YOKE AND PLATE ASSEMBLY—The removable end of connector link.

APPENDIX II

REFERENCES

CHAPTER ONE

Aircrew Survival Equipmentman 3 & 2, Vol 2, NAVEDTRA 10329, Naval Education and Training Program Development Center, Pensacola, Florida, 1983.¹

Emergency Personnel and Drouge Parachute Systems Manual, NAVAIR 13-1-6.2, Naval Air Systems Command, Washington, D.C., October 1988.

Cartridges and Cartridge Actuated Devices for Aircraft and Associated Equipment, NAVAIR 11-100-1.1, Naval Air Systems Command, Washington, D.C., January 1984.

Naval Aviation Maintenance Program (NAMP), OPNAVINST 4790.2 (Series), Office of Chief of Naval Operations, January, 1989.

CHAPTER TWO

Aircrew Survival Equipmentman 3 & 2, Vol 2, NAVEDTRA 10329, Naval Education and Training Program Development Center, Pensacola, Florida, 1983.¹

Emergency Personnel and Drouge Parachute Systems Manual, NAVAIR 13-1-6.2, Naval Air Systems Command, Washington, D.C., October, 1988.

Cartridges and Cartridge Actuated Devices for Aircraft and Associated Equipment, NAVAIR 11-100-1.1, Naval Air Systems Command, Washington, D.C., September 1984.

Naval Aviation Maintenance Program (NAMP), OPNAVINST 4190.2 (Series), Office of Chief of Naval Operations, January 1989.

CHAPTER THREE

Aircrew Survival Equipmentman 3 & 2, Vol 2, NAVEDTRA 10329, Naval Education and Training Program Development Center, Pensacola, Florida, 1983.¹

¹Effective 1 September 1986, the Naval Education and Training Program Development Center (NETPDC) was officially changed to Naval Education and Training Program Management Support Activity (NETPMSA).

Emergency Personnel and Drouge Parachute Systems Manual, NAVAIR 13-1-6.2, Naval Air Systems Command, Washington, D.C., October 1988.

CHAPTER FOUR

Aircrew Survival Equipmentman 3 & 2, Vol 1, NAVEDTRA 10328-1, Naval Education and Training Program Management Support Activity, Pensacola, Florida, 1987.

Emergency Personnel and Drouge Parachute Systems Manual, NAVAIR 13-1-6.2, Naval Air Systems Command, Washington, D.C., October 1988.

Rescue and Survival Equipment Manual, NAVAIR 13-1-6.5, Naval Air Systems Command, Washington, D.C., February 1988.

Aircrew Personal Protective Equipment Manual, NAVAIR 13-1-6.7, Naval Air Systems Command, Washington, D.C., January 1989.

NATOPS General Flight and Operational Instructions Manual, OPNAVINST 3710.7 (Series), Office of Chief of Naval Operations, July 1987.

Naval Aviation Maintenance Program (NAMF), OPNAVINST 4790.2 (Series), Office of Chief of Naval Operations, January 1989.

CHAPTER FIVE

Aircrew Survival Equipmentman 3 & 2, Vol 1, NAVEDTRA 10328-1, Naval Education and Training Program Management Support Activity, Pensacola, Florida, 1987.

Rescue and Survival Equipment Manual, NAVAIR 13-1-6.5, Naval Air Systems Command, Washington, D.C., February 1988.

CHAPTER SIX

Aircrew Survival Equipmentman 3 & 2, Vol 2, NAVEDTRA 10329, Naval Education and Training Program Development Center, Pensacola, Florida, 1983.²

Inflatable Survival Equipment Manual, NAVAIR 13-1-6.1, Naval Air Systems Command, Washington, D.C., January 1989.

CHAPTER SEVEN

Aircrew Survival Equipmentman 3 & 2, Vol 2, NAVEDTRA 10329, Naval Education and Training Program Development Center, Pensacola, Florida, 1983.²

²Effective 1 September 1986, the Naval Education and Training Program Development Center (NETPDC) was officially changed to Naval Education and Training Program Management Support Activity (NETPMSA).

Aviation Crew Systems Seat Survival Kits Manual, NAVAIR 13-1-6.3, Naval Air Systems Command, Washington, D.C., January 1989.

CHAPTER EIGHT

Aircrew Survival Equipmentman 3 & 2, Vol 1, NAVEDTRA 10328-1, Naval Education and Training Program Management Support Activity, Pensacola, Florida, 1987.

CHAPTER NINE

Aircrew Survival Equipmentman 3 & 2, Vol 1, NAVEDTRA 10328-1, Naval Education and Training Program Management Support Activity, Pensacola, Florida, 1987.

CHAPTER TEN

Aircrew Survival Equipmentman 3 & 2, Vol 1, NAVEDTRA 10328-1, Naval Education and Training Program Management Support Activity, Pensacola, Florida, 1987.

CHAPTER ELEVEN

Aircrew Survival Equipmentman 3 & 2, Vol 2, NAVEDTRA 10329, Naval Education and Training Program Development Center, Pensacola, Florida, 1983.³

Oxygen Equipment Manual, NAVAIR 13-1-6.4, Naval Air Systems Command, Washington, D.C., December 1988.

CHAPTER TWELVE

Aircrew Survival Equipmentman 3 & 2, Vol 2, NAVEDTRA 10329, Naval Education and Training Program Development Center, Pensacola, Florida, 1983.³

Oxygen Equipment Manual, NAVAIR 13-1-6.4, Naval Air Systems Command, Washington, D.C., December 1988.

³Effective 1 September 1986, the Naval Education and Training Program Development Center (NETPDC) was officially changed to Naval Education and Training Program Management Support Activity (NETPMSA).

INDEX

A

Acceptance/special/daily inspections, 12-8 to 12-9

Adapters, harness hardware, 1-12

Aircraft panel-mounted regulators, 12-6 to 12-18

- acceptance/special/daily inspections, 12-8 to 12-9
- calendar/phased/SDLM inspections, 12-9 to 12-18
- maintenance, 12-7
- turnaround/preflight/postflight/transfer inspections, 12-7 to 12-8

Aircrew personal protective equipment, 4-1 to 4-32

- anti-g garments, 4-12 to 4-15
 - CSU-15/P anti-g garment, 4-13 to 4-14
 - fitting the CSU-15/P anti-g garment, 4-13
 - inspections, 4-14
 - installing the CSU-15/P anti-g garment hose, 4-14
- maintenance, 4-15
- helmets, 4-18
 - helmet configuration buildup, 4-21
 - inspections, 4-23
 - calendar inspection, 4-23
 - functional check, 4-23
 - visual inspection, 4-23
 - maintenance, 4-21 to 4-22
 - addition of reflective tape, 4-22
 - cleaning, 4-22
 - major helmet assemblies, 4-19 to 4-20
 - major helmet components, 4-20 to 4-21
 - sizing the PRK-37/P, 4-21
 - SPH-3C helmet, 4-23 to 4-24
 - fitting, 4-24
 - maintenance procedures, 4-24

Aircrew personal protective equipment— Continued

- integrated torso harnesses, 4-15 to 4-18
 - fitting, 4-16 to 4-17
 - inspections, 4-18
 - lap belt shoulder adjustments, 4-17
 - sizing, 4-16
- maintenance scheduling and records, 4-1 to 4-3
- maintenance documents, 4-1 to 4-3
 - aircrew personal protective equipment history card, 4-2
- Aircrew Personal Protective Equipment Manual, NAVAIR 13-1-6.7, 4-3
- history card-aviation crew systems, 4-2
- maintenance data collection system forms, 4-2
- shop process cards (SPC), 4-2
- modifications of flight equipment, 4-3
- oxygen masks, 4-24 to 4-32
 - attachment of bayonet and receiver mechanism, 4-28 to 4-31
 - adjustment of bayonet receivers, 4-31
 - fitting, 4-29 to 4-30
 - maintenance, 4-31
 - preflight/postflight inspection, 4-31 to 4-32
 - calendar inspection, 4-31
 - cleaning mask, 4-31 to 4-32
 - pressure-demand oxygen mask MBU-12/P, 4-24 to 4-28
 - combination inhalation/exhalation valve, 4-26
 - sizing, 4-26 to 4-28

Aircrew personal protective equipment—
Continued

- types of flight clothing, 4-3 to 4-12
 - antiexposure assemblies, 4-6 to 4-12
 - A/P22P-6(V)2 and A/P22P-6A(V)2 antiexposure assemblies, 4-8 to 4-12
 - fire-resistant flyer's gloves, GS/FRP-2, 4-4 to 4-5
 - configuration, 4-4 to 4-5
 - fitting, 4-5
 - maintenance, 4-5
 - flyer's boot, 4-5
 - configuration, 4-5 to 4-6
 - fitting, 4-6
 - maintenance, 4-6
 - summer flyer's coverall CWU-27/P and blue flyer's coverall CWU-73/P, 4-3 to 4-4
 - configuration, 4-4
 - fitting, 4-4
 - maintenance, 4-4
 - SV-2 survival vest, 4-6
 - configuration, 4-6
 - fittings, 4-6
- AN/PRC-63 radio set, 5-5 to 5-7
- AN/PRC-90 radio set, 5-7 to 5-10
- AN/PRT-5 transmitting set, 5-11 to 5-12
- Automatic opening devices, 2-1 to 2-15
 - automatic parachute actuators, 2-1 to 2-9
 - arming and assembling the automatic parachute ripcord release, 2-7 to 2-8
 - automatic parachute ripcord release test set, 2-5 to 2-6
 - checkout of armed ripcord release, 2-8 to 2-9
 - disarming, 2-3
 - firing altitude check, 2-5
 - function, 2-2
 - inspection, 2-4 to 2-5
 - maintenance, 2-3
 - preparation for use, 2-2
 - ripCord release test procedure, 2-6 to 2-7
 - ballistic spreading gun assembly, 2-9 to 2-15
 - ballistic spreading gun cartridge replacement and pull-force check, 2-12 to 2-15
 - description, 2-10 to 2-11
 - identification and handling, 2-11
 - log entries, 2-11
 - safety precautions, 2-11
 - service life, 2-11

Automatic opening devices—Continued

- ballistic spreading gun assembly—Continued
 - operation, 2-11
 - removal of ballistic spreading gun, 2-12
- Automatic parachute ripcord release assembly, installation of, 3-10 to 3-11
- Awl, hand tool, 10-12

B

- Ballistic spreading gun assembly, 2-9 to 2-15
- Ballistic spreading gun inspection, 1-28
- Beacon set radio, AN/URT-33A, 5-10 to 5-11
- Bell jar, 11-14 to 11-15
- Binder's knot, 10-29
- Bowline knot, 10-29

C

- Cable grip, 5-21 to 5-22
- Calendar inspection, 12-26 to 12-33
 - bench test, 12-27
 - capacitance test (empty), 12-28
 - capacitance test (full), 12-30 to 12-31
 - converter assembly purge, 12-27 to 12-28
 - converter charge, 12-32 to 12-33
 - converter leakage test, 12-29 to 12-30
 - evaporation loss test (buildup and supply mode), 12-31
 - evaporation loss test (vented mode), 12-31 to 12-32
 - fill and buildup time test, 12-30
 - flow test, 12-32
 - insulation resistance test (empty), 12-28
 - relief valve test, 12-28 to 12-29
 - service life, 12-27
 - visual inspection, 12-27
- Calendar/phased/SDLM inspections, 12-9 to 12-18
 - bench test, 12-9
 - inward leakage test, 12-9 to 12-18
 - service life, 12-9
- Canopies, 1-6 to 1-10
- Canopy damage charts, parachutes, 1-21 to 1-22
- Carbon dioxide, 8-1 to 8-5
 - CO₂ recharge equipment, 8-1 to 8-2
 - CO₂ supply cylinders, 8-2

Carbon dioxide—Continued

- inspecting CO₂ cylinders and recharging, 8-2 to 8-5
- maintenance for the C-O-TWO transfer unit, 8-5
- maintenance of the Walter Kidde transfer unit, 8-5

Class 111 sewing machines, 9-18

Clothing, types of flight, 4-3 to 4-12

Clove hitch knot, 10-30

Components of parachutes, 1-5 to 1-11

Configuration and function, 12-18 to 12-21

Connector link ties, installation of, 3-12 to 3-13

Consew 99R and 99R-3 sewing machines, 9-34 to 9-39

Containers, parachute, 1-10

Converter supply connection, NIP-6, 11-15 to 11-16

Converter test stands, liquid oxygen, 11-13 to 11-21

CSU-15/P anti-g garment, 4-13 to 4-14

Curtain fastener, 10-15

CWU-27/P, summer flyer's coverall and CWU-73/P blue flyer's coverall, 4-3 to 4-4

D

Daily/preflight inspection, 12-2 to 12-6

- bench test, 12-3 to 12-6
- calendar inspection, 12-2
- special inspections, 12-2
- visual inspection, 12-2 to 12-3

Demonstrating the use of rafts, 6-16 to 6-19

- boarding the raft, 6-18
- safety precautions in boarding rafts, 6-18 to 6-19

Differential pressure gauge, DF-1, 11-15

Distress light (SDU-5/E), 5-3

Dye marker, 5-1

E

Engineering requirements for fabrics, 10-6 to 10-9

External pilot parachute, 3-6 to 3-7

F

Fabrication and manufacture, 10-1 to 10-30
hardware, 10-12 to 10-20

- curtain fastener, 10-15
- glove fasteners, 10-13 to 10-14
 - hand installation, 10-14
 - press installation, 10-14
- grommets, 10-12 to 10-13
 - grommet press installation 10-13
 - grommet set installation, 10-13
- interlocking slide fasteners, 10-15 to 10-20
 - fabrication, 10-18 to 10-19
 - interlocking slide fastener construction, 10-16
 - interlocking slide fastener operation, 10-16 to 10-17
 - interlocking slide fastener tools, 10-17
 - interlocking slide fastener repair, 10-17 to 10-18
 - installing an interlocking slide fastener, 10-18
 - procurement of slide fasteners, 10-19 to 10-20
 - shortening an interlocking slide fastener, 10-18
 - slide fastener pressure foot, 10-18

- three-way locking fasteners, 10-14
- three-way locking snaps, 10-14 to 10-15
- seams and knots, 10-20 to 10-30
 - hand-sewn seams, 10-20 to 10-24
 - hand sewing the running stitch, 10-22
 - hand-sewn overthrow stitch, 10-22 to 10-23
 - purposes and characteristics of the basting stitch, 10-22
 - sewing the baseball stitch, 10-23 to 10-24
 - use of the hand-sewn hidden stitch and the needle used, 10-24
 - knots, 10-28 to 10-30
 - binders knot, 10-29
 - bowline, 10-29
 - clove hitch, 10-30
 - half hitch, 10-29 to 10-30
 - overhand knot, 10-28

Fabrication and manufacture—Continued
 seams and knots—Continued
 knots—Continued
 square knot, 10-29
 surgeon's knot, 10-29
 machine-sewn seams, 10-24 to 10-28
 advantages and characteristics of
 a machine-sewn seam, 10-25
 appropriate spacing of machine-
 sewn seams, 10-27 to 10-28
 meanings and symbols of
 machine-sewn basic stitches,
 10-25 to 10-26
 uses of varying classes of
 machine-sewn seams and
 stitchings, 10-26 to 10-27
 special hand tools, 10-9 to 10-12
 awl, 10-12
 foot-operated grommet press, 10-10
 hand press, 10-10
 knife, 10-10, 10-11
 measuring devices, 10-11 to 10-12
 sailmaker's palm, 10-12
 shears, 10-9 to 10-10
 star punch, 10-12
 textile materials, terms, and meanings,
 10-1 to 10-9
 construction features and uses of
 various textile materials, 10-2 to
 10-4
 cotton, 10-3
 duck, 10-3
 leather, 10-4
 NOMEX fabric, 10-3
 nylon, 10-3
 rubber, 10-3
 vinyl, 10-4
 difference between threads and
 cords, 10-4 to 10-5
 cords, 10-5
 threads, 10-4 to 10-5
 engineering requirements for fabrics,
 10-6 to 10-9
 air permeability, 10-6
 elasticity (or elastic recovery),
 10-7 to 10-8
 elongation, 10-7
 moisture regain, 10-8
 resistance to abrasion, 10-8
 resistance to chemicals, 10-8 to
 10-9
 resistance to heat, 10-8
 resistance to mildew and insects,
 10-8
 resistance to sunlight, 10-8

Fabrication and manufacture—Continued
 textile materials, terms, and meanings—
 Continued
 engineering requirements for fabrics—
 Continued
 strength, 10-6
 weight, 10-8
 fiber and filament, 10-1 to 10-2
 bias, 10-2
 cloth weight, 10-2
 filling, 10-2
 selvage and raw edges, 10-2
 staple, 10-1
 tensile strength, 10-2
 warp, 10-2
 weave, 10-2
 yarn, 10-1
 storage of textile materials, 10-5
 to 10-6
 webbings and tapes, 10-4
 tapes, 10-4
 webbings, 10-4
 Fire-resistant flyer's gloves, GS/FRP-2, 4-4 to
 4-5
 Flight clothing, types of, 4-3 to 4-12
 Flyer's boot, 4-5
 Forest penetrator and flotation collar, 5-15 to
 5-17

G

Garments, anti-g, 4-12 to 4-15
 CSU-15/P anti-g garments, 4-13 to 4-14
 maintenance, 4-15
 Gauges and indicators, 11-7 to 11-8
 General packet, 5-4
 Glossary, AI-1 to AI-17
 Glove fasteners, 10-13 to 10-14
 hand installation, 10-14
 press installation, 10-14
 Grommet press, foot-operated, 10-10
 Grommets, 10-12 to 10-13
 grommet press installation, 10-13
 grommet set installation, 10-13
 GS/FRP-2, fire-resistant flyer's gloves, 4-4 to
 4-5

H

Half hitch knot, 10-29 to 10-30
 Hand press, 10-10

Hand-sewn seams, 10-20 to 10-24
 Hardware, 10-12 to 10-20
 curtain fastener, 10-15
 glove fasteners, 10-13 to 10-14
 grommets, 10-12 to 10-13
 interlocking slide fasteners, 10-15 to 10-20
 three-way locking fasteners, 10-14
 three-way locking snaps, 10-14 to 10-15
 Harness hardware, 1-11 to 1-13
 adapters, 1-12
 connector links, 1-13
 Koch release adapters, 1-13
 snaps, 1-12 to 1-13
 Harness, parachute, 1-10
 Helicopter rescue devices, 5-12 to 5-24
 Helmets, 4-18 to 4-24
 helmet configuration buildup, 4-21
 inspections, 4-23
 maintenance, 4-21 to 4-22
 major helmet assemblies, 4-19 to 4-20
 major helmet components, 4-20 to 4-21
 sizing the PRK-37/P, 4-21
 SPH-3C helmet, 4-23 to 4-24
 Hydrostatic test of CO₂ cylinders, 6-4 to 6-5
 Hypoxia, effects of, 11-2

I

Illumination signal kit, Mk 79, Mod 0 5-2
 Inflatable survival equipment, 6-1 to 6-35
 demonstrating the use of rafts, 6-16 to 6-19
 boarding the raft, 6-18
 safety precautions in boarding rafts, 6-18 to 6-19
 inspections, 6-1 to 6-5
 cleaning, 6-4
 determination of repairability, 6-2
 functional test, 6-2 to 6-3
 hydrostatic test of CO₂ cylinders, 6-4 to 6-5
 leakage testing, 6-3 to 6-4
 pull cable proof load test for multiplace rafts, 6-3
 life preserver inspections, 6-28 to 6-35
 functional testing, 6-30
 inflation assembly inspection, 6-33 to 6-35
 battery replacement, LPU-23/P (series) and LPU-24/P (series), 6-35

Inflatable survival equipment—Continued
 life preserver inspections—Continued
 inflation assembly inspection—Continued
 installation of cylinders: LPA-1/1A (series), LPA-2 (series), LPU-21/P (series), LPU-30/P, and LPP-1 (series), 6-34
 installation of cylinders, LPU-23/P (series) and LPU-24/P (series), 6-34 to 6-35
 leakage test, 6-30 to 6-32
 test fixture, 6-30
 test procedure, 6-30 to 6-32
 visual inspection, 6-32 to 6-33
 battery visual inspection, LPU-23/P (series) and LPU-24/P (series), 6-32
 battery voltage testing, LPU-23/P (series) and LPU-24/P (series), 6-32 to 6-33
 life preservers, 6-22 to 6-28
 LPP-1/1A life preserver assembly, 6-26
 LPU-21/P series life preserver assembly, 6-22 to 6-24
 LPU-23/P series life preserver assembly, 6-24 to 6-26
 LPU-24/P series life preserver assembly, 6-26
 LPU-30/P life preserver assembly, 6-26 to 6-28
 LRU-12/A life raft assembly, 6-8 to 6-10
 LRU-13/A life raft assembly, 6-10 to 6-13
 equipment and survival items, 6-10
 packing procedures remote or local pull, 6-10 to 6-13
 LRU-14 series life raft assembly, 6-13 to 6-15
 equipment and survival items, 6-14 to 6-15
 operation, 6-15
 LRU-15/A life raft assembly, 6-15 to 6-16
 emergency repairs, 6-16
 equipment and survival items, 6-16
 multiplace rafts, 6-5 to 6-8
 bulkheads, 6-6
 combination supply pocket and bailer, 6-7
 inflatable seats, 6-6
 lifeline, 6-7
 righting handles, 6-7

Inflatable survival equipment—Continued
 multiplace rafts—Continued
 seam tapes and patches, 6-5 to 6-6
 supply pocket, 6-6 to 6-7
 topping-off valves, 6-7 to 6-8
 one-man life rafts, 6-19 to 6-22
 LR-1 life raft assembly, 6-20 to 6-22
 ballast bags, 6-21
 boarding handles, 6-21
 flotation tube, 6-20
 inspection, 6-22
 oral inflation tube, 6-20 to 6-21
 retaining line, 6-21
 sea anchor, 6-21
 sea anchor pocket, 6-21
 securing line, 6-21
 survival items, 6-21 to 6-22
 weathershield, 6-21
 LRU-7/P life raft assembly, 6-19 to 6-20
 Inspection, daily/preflight, 12-2 to 12-6
 bench test, 12-3 to 12-6
 calendar inspections, 12-2
 special inspections, 12-2
 visual inspection, 12-2 to 12-3
 Inspections, 7-3 to 7-9
 acceptance/phased/SDLM inspections, 7-4 to 7-8
 functional check, 7-7 to 7-8
 swaged ball pull test, 7-4 to 7-7
 visual inspection, 7-4
 purging and charging emergency oxygen systems, 7-8 to 7-9
 Inspections, personnel parachute, 1-14 to 1-16
 inspection schedules, 1-16
 parachute maintenance, 1-16
 reasons for inspecting parachutes, 1-14 to 1-16
 specifications, 1-16
 Inspections, procedures for preliminary tests, 1-24 to 1-30
 Integrated torso harnesses, 4-15 to 4-18
 Interlocking slide fasteners, 10-15 to 10-20

K

Kit, seat survival, 7-1 to 7-9
 Knife, hand tool, 10-10 to 10-11
 Knots, 10-28 to 10-30
 binder's knot, 10-29
 bowline, 10-29
 clove hitch, 10-30
 half hitch, 10-29 to 10-30
 overhand know, 10-28

Knots—Continued
 square knot, 10-29
 surgeon's knot, 10-29
 Koch release adapters, harness hardware, 1-13

L

Life preservers, 6-22 to 6-35
 Lifeline, rafts, 6-7
 Linear flow elements, 11-16
 Liquid oxygen converters, 12-18
 Liquid oxygen quantity gauge capacitor-type tester, 11-16
 LPP-1/1A life preserver assembly, 6-26
 LPU-21/P series life preserver assembly, 6-22 to 6-24
 LPU-23/P series life preserver assembly, 6-24 to 6-26
 LPU-24/P series life preserver assembly, 6-26
 LPU-30/P life preserver assembly, 6-26 to 6-28
 LR-1 life raft assembly, 6-20 to 6-22
 LRU-7/P life raft assembly, 6-19 to 6-20
 LRU-12/A life raft assembly, 6-8 to 6-10
 LRU-13/A life raft assembly, 6-10 to 6-13
 equipment and survival items, 6-10
 packing procedures remote or local pull, 6-10 to 6-13
 LRU-14 series life raft assembly, 6-13 to 6-15
 equipment and survival items, 6-14 to 6-15
 operation, 6-15
 LRU-15/A life raft assembly, 6-15 to 6-16
 emergency repairs, 6-16
 equipment and survival items, 6-16

M

Machine-sewn seams, 10-24 to 10-28
 Maintenance, 12-24 to 12-26
 acceptance/turnaround/daily/preflight/postflight and transfer inspections, 12-24
 functional test, 12-25 to 12-26
 visual inspection, 12-25
 Maintenance records and inspection parachute, 1-16 to 1-22
 Maintenance scheduling and records, 4-1 to 4-3
 maintenance documents, 4-1 to 4-3
 modifications of flight equipment, 4-3
 Manometer preparation, 11-10
 Medical packet, 5-3

Mirror, signaling, 5-1 to 5-2
Mk 13, Mod 0 signal flare, 5-2 to 5-3
Mk 79, Mod 0 illumination signal kit, 5-2
Multiplace rafts, pull cable proof load test, 6-3

N

NAMP, Naval Aviation Maintenance Program forms, 1-22
NES-12 personnel parachute system, 3-1 to 3-15
 rigging, 3-4 to 3-15
 attachment of container assembly to riser assembly, 3-12
 attachment of firing lanyard to suspension line connector link, 3-14 to 3-15
 external pilot parachute, 3-6 to 3-7
 installation of automatic parachute ripcord release assembly, 3-10 to 3-11
 installation of connector link ties, 3-12 to 3-13
 installation of release assembly lanyard and ripcord assembly, 3-13 to 3-14
 installation of spreading gun, 3-4 to 3-6
 preliminary procedures, 3-4
 stowage of firing lanyard into extractor sleeve, 3-8 to 3-10
 straightening canopy gores with spreader gun installed, 3-8
 suspension line continuity check with spreading gun installed, 3-7 to 3-8
Net, rescue, 5-17 to 5-18

O

One-man life rafts, 6-19 to 6-22
 LR-1 life raft assembly, 6-20 to 6-22
 LRU-7/P life raft assembly, 6-19 to 6-20
OPNAV 4790/38, preflight/daily/turnaround/postflight maintenance record, 1-17
OPNAV 4790/101, parachute configuration, inspection and history record, 1-17 to 1-27
Oscillating type sewing machines, 9-3 to 9-18

Overhand knot, 10-28
Oxygen components test stands, 11-1 to 11-21
 liquid oxygen converter test stands, 11-13 to 11-21
 cleaning, 11-21
 functions, 11-14 to 11-16
 bell jar, 11-14 to 11-15
 converter supply connection, NIP-6, 11-15 to 11-16
 differential pressure gauge, DF-1, 11-15
 flow of oxygen, 11-16
 linear flow elements, 11-16
 liquid oxygen quantity gauge capacitor-type tester, 11-16
 relief valve, RV-11, 11-15
 maintenance, 11-16 to 11-21
 installation, 11-18
 test stand leakage tests, 11-18
 visual inspection, 11-18
 periodic inspections, 11-21
 troubleshooting, 11-21
 maintenance, 11-10 to 11-13
 manometer preparation, 11-10
 periodic inspections, 11-12 to 11-13
 altitude chamber and suit simulator tank inward leakage test, 11-12
 biweekly inspection, 11-13
 daily inspection, 11-12
 monthly inspection, 11-13
 weekly inspection, 11-12
 pressure/leakage tests, 11-10
 leakage control valve(E) and leakage on/off valve (G) tests, 11-11
 outward leakage test (regulated high-pressure system), 11-11
 outward leakage test (regulated low-pressure system), 11-11
 outward leakage test (supply system), 11-11
 suit simulator system leakage tests, 11-11 to 11-12
 Vol-O-Flo calibration, 11-13
 Vol-O-Flo element cleaning, 11-13
oxygen, 11-1 to 11-3
 characteristics of oxygen, 11-2 to 11-3
 effects of hypoxia, 11-2
 types of oxygen, 11-3

Oxygen components test stands—Continued
oxygen component test stand 1172AS100,
11-3 to 11-10
check valve connections, 11-9
control valves, 11-6 to 11-7
measuring control valves, 11-6
to 11-7
nonmeasuring control valves,
11-7
gauges and indicators, 11-7 to 11-8
on/off valves, 11-4
regulators, 11-7
safety precautions, 11-10
selector valves, 11-4
shutoff valves, 11-7
test stand connections, 11-8
vacuum pump, 11-9 to 11-10
Vol-O-Flo elements, 11-4 to 11-6

Oxygen masks, 4-24 to 4-32
attachment of bayonet and receiver
mechanism, 4-28 to 4-31
preflight/postflight inspection, 4-31 to
4-32
pressure-demand oxygen mask MBU-12/P,
4-24 to 4-28

Oxygen-related components, 12-1 to 12-33
aircraft panel-mounted regulators, 12-6 to
12-18
acceptance/special/daily inspections,
12-8 to 12-9
calendar/phased/SDLM inspections,
12-9 to 12-18
bench test, 12-9
inward leakage test, 12-9 to
12-18
service life, 12-9
maintenance, 12-7
turnaround/preflight/postflight/
transfer inspections, 12-7 to 12-8
calendar inspection, 12-26 to 12-33
bench test, 12-27
capacitance test (empty), 12-28
capacitance test (full), 12-30 to 12-31
converter assembly purge, 12-27 to
12-28
converter charge, 12-32 to 12-33
converter leakage test, 12-29 to 12-30
evaporation loss test (buildup and
supply mode), 12-31
evaporation loss test (vented mode),
12-31 to 12-32
fill and buildup time test, 12-30
flow test, 12-32
insulation resistance test (empty),
12-28

Oxygen related components—Continued
calendar inspection—Continued
relief valve test, 12-28 to 12-29
service life, 12-27
visual inspection, 12-27
configuration and function, 12-18 to
12-21
daily/preflight inspection, 12-2 to 12-6
bench test, 12-3 to 12-6
calendar inspection, 12-2
special inspections, 12-2
visual inspection, 12-2 to 12-3
liquid oxygen converters, 12-18
maintenance, 12-24 to 12-26
acceptance/turnaround/daily/pre-
flight/postflight and transfer
inspections, 12-24
functional test, 12-25 to 12-26
visual inspection, 12-25
performance testing, 12-21 to 12-24
converter charge, 12-24
converter leakage, 12-24
fill and buildup time, 12-24
flow, 12-24
performance test sheet preparation,
12-23 to 12-24
relief valve, 12-24

P

Parachute actuators, automatic, 2-1 to 2-9
Performance testing, 12-21 to 12-24
converter charge, 12-24
converter leakage, 12-24
fill and buildup time, 12-24
flow, 12-24
relief valve, 12-24

Personnel parachute familiarization, 1-1 to
1-30
compliance with current directives, 1-30
components of parachutes, 1-5 to 1-11
canopies, 1-6 to 1-10
parachute containers, 1-10
parachute harness, 1-10
pilot chute, 1-5 to 1-6
ripords, 1-11
suspension lines, 1-10
harness hardware, 1-11 to 1-13
adapters, 1-12
connector links, 1-13
Koch release adapters, 1-13
snaps, 1-12 to 1-13

Personnel parachute familiarization—
Continued

- harness hardware—Continued
 - inspections, 1-22 to 1-24
 - acceptance (original issue) calendar/
phased/conditional inspections,
1-22 to 1-24
 - aircraft accident report inspec-
tion, 1-23 to 1-24
 - calendar/phased, 1-23
 - conditional inspection, 1-23
 - original issue/acceptance, 1-23
 - postcombat inspection, 1-23
 - daily inspection, 1-22
 - special inspection, 1-22
- parachute inspection and maintenance
records, 1-16 to 1-22
 - canopy damage charts, 1-21 to 1-22
 - Naval Aviation Maintenance Program
forms, 1-22
 - parachute configuration, inspection
and history record (OPNAV
4790/101), 1-17 to 1-21
 - cartridges and cartridge-actuated
devices, 1-19
 - configuration verification (a list
of each item that has a service
life), 1-19 to 1-20
 - initiation, 1-19
 - miscellaneous history, 1-19
 - procedures, 1-20 to 1-21
 - technical directives, 1-19
 - preflight/daily/turnaround/postflight
maintenance record (OPNAV
4790/38), 1-17
 - recording modifications, 1-22
- personnel parachute inspections, 1-14 to
1-16
 - inspection schedules, 1-16
 - parachute maintenance, 1-16
 - reasons for inspecting parachutes,
1-14 to 1-16
 - specifications, 1-16
- procedures for preliminary tests and
inspections, 1-24 to 1-30
 - ballistic spreading gun inspection,
1-28
 - canopy inspection, 1-25 to 1-26
 - connector link inspection, 1-27 to
1-28
 - container assembly inspection, 1-29
to 1-30

Personnel parachute familiarization—
Continued

- procedures for preliminary tests and
inspections—Continued
 - contamination inspection, 1-24 to
1-25
 - acid and alkaline contamination,
1-25
 - other contaminations, 1-25
 - harness/riser assembly inspection
1-28
 - harness/riser assembly inspection,
1-28
 - cross-connector strap inspection,
1-29
 - hardware inspection, 1-28 to
1-29
 - inspecting for wear and physical
defects, 1-25
 - pilot parachute inspection, 1-25
 - replacement of parachute assemblies
and subassemblies, 1-24
 - ripcord assembly inspection, 1-29
 - ripcord handle clip inspection,
1-29
 - ripcord handle pocket inspection,
1-29
 - ripcord pull test, 1-24
 - service life checks, 1-24
 - suspension and vent line inspection,
1-26 to 1-27
 - transporting parachutes, 1-13 to 1-14
 - shipping-containers, 1-13 to 1-14
 - storing, 1-14
- Pneumatic rescue hand tool, 5-22 to 5-24
- Preservers, life, 6-22 to 6-35
- Pressure/leakage tests, 11-10
- Pull cable proof load test for multiplace
rafts, 6-3
- Purging and charging emergency oxygen
systems, 7-8 to 7-9

R

- Rafts, multiplace, 6-5 to 6-8
 - bulkheads, 6-6
 - combination supply pocket and bailer,
6-7
 - inflatable seats, 6-6
 - lifeline, 6-7
 - right handles, 6-7
 - seam tapes and patches, 6-5 to 6-6
 - supply pocket, 6-6 to 6-7
 - topping-off valves, 6-7 to 6-8

- Rations, 5-4
 - References, AII-1 to AII-3
 - Release assembly lanyard and ripcord
 - assembly, installation of, 3-13 to 3-14
 - Relief valve, RV-11, 11-15
 - Rescue and survival equipment, 5-1 to 5-24
 - canned drinking water, 5-4 to 5-5
 - helicopter rescue devices, 5-12 to 5-24
 - cable grip, 5-21 to 5-22
 - calendar inspection, 5-22
 - cleaning, 5-22
 - maintenance, 5-22
 - forest penetrator and flotation collar, 5-15 to 5-17
 - cleaning, 5-16 to 5-17
 - inspection, 5-16
 - maintenance, 5-16
 - hoist quick-splice plate, 5-21
 - calendar inspection, 5-21
 - cleaning, 5-21
 - maintenance, 5-21
 - pneumatic rescue hand tool, 5-22 to 5-24
 - calendar inspection, 5-23 to 5-24
 - cleaning, 5-24
 - maintenance, 5-23
 - rescue harness, 5-18 to 5-20
 - calendar inspection, 5-18 to 5-20
 - cleaning, 5-20
 - maintenance, 5-18
 - preflight inspection, 5-18
 - rescue hook, 5-20 to 5-21
 - calendar inspection, 5-21
 - cleaning, 5-21
 - maintenance, 5-20
 - rescue net, 5-17 to 5-18
 - cleaning, 5-18
 - inspection, 5-18
 - maintenance, 5-18
 - rescue seat, 5-14, to 5-15
 - cleaning, 5-15
 - inspection, 5-15
 - maintenance, 5-15
 - survivor's sling, 5-13 to 5-14
 - calendar inspections, 5-14
 - maintenance, 5-14
 - individual aircrewman's survival kit (SRU-31/P), 5-3 to 5-4
 - general packet, 5-4
 - inspection, 5-4
 - medical packet, 5-3
 - Rescue and survival equipment—Continued
 - rations, 5-4
 - signaling equipment and devices, 5-1 to 5-3
 - distress light (SDU-5/E), 5-3
 - dye marker, 5-1
 - Mk 13 Mod 0 signal flare, 5-2 to 5-3
 - Mk 79, Mod 0 illumination signal kit, 5-2
 - signaling mirror, 5-1 to 5-2
 - survival radios and beacons, 5-5 to 5-12
 - AN/PRC-63 radio set, 5-5 to 5-7
 - battery replacement, 5-7
 - function and use of operating controls, 5-6
 - general principles of operation, 5-5 to 5-6
 - inspections, 5-7
 - AN/PRC-90 radio set, 5-7 to 5-10
 - batteries, 5-8
 - operating procedure, 5-8 to 5-10
 - AN/PRT-5 transmitting set, 5-11 to 5-12
 - AN/URT-33A beacon set radio, 5-10 to 5-11
 - Rigging, parachute, 3-4 to 3-15
 - Ripcord pull test, 1-24
 - Ripcords, parachute, 1-11
 - Rotary sewing machines, 9-18 to 9-39
 - RSSK-8 series seat survival kit, 7-1 to 7-3
- S**
- Safety precautions, 11-10
 - Sailmaker's palm, hand tool, 10-12
 - SDU-5/E, distress light, 5-3
 - Seams and knots, 10-20 to 10-30
 - hand-sewn seams, 10-20 to 10-24
 - knots 10-28, to 10-30
 - machine-sewn seams, 10-24 to 10-28
 - Seat, rescue, 5-14 to 5-15
 - Seat survival kit, 7-1 to 7-9
 - inspections, 7-3 to 7-9
 - acceptance/phased/SDLM inspections, 7-4 to 7-8
 - functional check, 7-7 to 7-8
 - swaged ball pull test, 7-4 to 7-7
 - visual inspection, 7-4
 - purging and charging emergency oxygen systems, 7-8 to 7-9
 - RSSK-8 series seat survival kit, 7-1 to 7-3
 - Seats, inflatable, 6-6

Sewing machines, 9-1 to 9-39

oscillating type sewing machines, 9-3 to 9-18

Singer sewing machine 7-33, 9-13 to 9-18

lubrication, 9-14

modification of presser foot for webbing sewing, 9-17 to 9-18

needles and thread, 9-14

preparing the sewing, 9-17

regulating the length of stitch, 9-17

regulating the pressure on the material, 9-17

regulating the tension, 9-16 to 9-17

removing the bobbin, 9-16

removing the work, 9-17

replacing the bobbin and threading the shuttle, 9-16

setting the needle, 9-15

threading the machine, 9-15 to 9-16

winding the bobbin, 9-16

Singer sewing machine 31-15, 9-3 to 9-13

adjusting the feed dog, 9-8

adjusting the thread take-up spring, 9-8 to 9-13

commencing to sew, 9-12

lubrication, 9-4

preparing for sewing, 9-12

regulating the length of a stitch, 9-13

regulating the pressure on the material, 9-13

regulating the tension, 9-12 to 9-13

removing the bobbin case, 9-10

removing work, 9-13

replacing the bobbin case, 9-12

replacing the needle, 9-8 to 9-9

threading the bobbin case, 9-11 to 9-12

threading the machine, 9-10

timing the 31-15, 9-4 to 9-6

timing the feed dog with the needle, 9-6 to 9-7

timing the needle with the shuttle, 9-6

winding the bobbin, 9-10 to 9-11

rotary sewing machines, 9-18 to 9-39

class 111 sewing machines, 9-18

Consew 99R and 99R-3 sewing machine, 9-34 to 9-39

adjusting the bobbin thread tension, 9-35

adjustment of the thread take-up spring, 9-39

centering the needle in the throat (needle) plate, 9-37

preparing the machine for rope stitching (model 99R-3 only), 9-36 to 9-37

regulating the tension, 9-35

regulating the pressure of the presser foot, 9-35

setting the needle bar at the correct height, 9-37

stitch regulator and reverse sewing and tacking, 9-36

straight and zigzag sewing, 9-36

threading the 99R and 99R-3 machines, 9-34 to 9-35

timing the feeding mechanism, 9-38 to 9-39

timing the movement of the needle bar frame, 9-39

timing the sewing hook, 9-37 to 9-38

to raise or lower the feed dog, 9-39

to remove and replace and the sewing hook, 9-38

different models of the 111 W sewing machine, 9-18 and 9-19

111 W 150 sewing machine, 9-18 to 9-19

111 W 151 sewing machine, 9-19

111 W 152 sewing machine, 9-19

111 W 153 sewing machine, 9-19

111 W 154 sewing machine, 9-19

111 W 155 sewing machine, 9-19

functional features, 9-19 to 9-26

lubrication of the class 111

sewing machine, 9-22 to 9-23

needles and thread, 9-23 to 9-24

operation, 9-24

preparing for sewing, 9-25

removing the bobbin, 9-24

removing the work, 9-25 to 9-26

regulating the length of stitch, 9-25

regulating the pressure on the material, 9-25

regulating the tension, 9-25

Sewing machines—Continued

rotary sewing machines—Continued

functional features—Continued

replacing the bobbin and
threading the bobbin case,
9-25

setting the needle, 9-24

threading the machine, 9-24

timing the 111 W class sewing
machines, 9-21 to 9-22

winding the bobbin, 9-25

Singer sewing machine 143 W 2 and
3, 9-30 to 9-33

bobbin and bobbin case, 9-31

needle and thread, 9-30

raising or lowering the feed dog,
9-33

regulating the length of the
stitch, 9-31

regulating the width of the
zigzag, 9-31

removing the work, 9-33

setting and timing the needle bar
frame, 9-32

setting the hook distance to or
from needle, 9-32 to 9-33

setting the needle, 9-30

setting the needle bar, 9-31 to
9-32

sewing techniques, 9-33

threading the needle, 9-31

timing sewing hook, 9-32

Singer sewing machine 211 W 151,
9-26 to 9-30

adjustments, 9-27 to 9-30

lubrication, 9-30

needles, 9-26 to 9-27

removing the air shaft connection
belt, 9-30

Shears, hand tool, 10-9 to 10-10

Signal flare, Mk13, Mod 0, 5-2 to 5-3

Signaling mirror, 5-1 to 5-2

Snaps, harness hardware, 1-12 to 1-13

Snaps, three-way locking, 10-14 to 10-15

Special inspections, 12-2

Spreading gun, installation of, 3-4 to
3-6

Square knot, 10-29

SRU-31/P, individual aircrewman's survival
kit, 5-3 to 5-4

general packet, 5-4

inspection, 5-4

medical packet, 5-3

Star punch, hand tools, 10-12

Summer flyer's coverall CWU-27/P and blue
flyer's coverall CWU-73/P, 4-3 to 4-4

Surgeon's knot, 10-29

Survival radios and beacons, 5-5 to 5-12

AN/PRC-63 radio set, 5-5 to 5-7

AN/PRC-90 radio set, 5-7 to 5-10

AN/PRT-5 transmitting set, 5-11 to
5-12

AN/URT-33A beacon set radio, 5-10 to
5-11

Survivor's sling, 5-13 to 5-14

Suspension line continuity check with
spreading gun installed, 3-7 to 3-8

SV-2 survival vest, 4-6

Swaged ball pull test, 7-4 to 7-7

T

Test stand 1172AS100 oxygen component,
11-3 to 11-10

Test stand connections, 11-8

Textile materials, terms, and meanings,
10-1 to 10-9

construction features and uses of various
textile materials, 10-2 to 10-4

difference between threads and cords,
10-4 to 10-5

engineering requirements for fabrics,
10-6 to 10-9

fiber and filament, 10-1 to 10-2

storage of textile materials, 10-5 to
10-6

webbings and tapes, 10-4

Three-way locking fasteners, 10-14

Three-way locking snaps, 10-14 to 10-15

Tools, special hand, 10-9 to 10-12

awl, 10-12

foot-operated grommet press, 10-10

hand press, 10-10

knife, 10-10 to 10-11

measuring devices, 10-11 to 10-12

sailmaker's palm, 10-12

shears, 10-9 to 10-10

star punch, 10-12

Transmitting set, AN/PRT-5, 5-11 to
5-12

Transporting parachutes, 1-13 to 1-14
shipping containers, 1-13 to 1-14
storing, 1-14
Turnaround/preflight/postflight/transfer
inspections, 12-7, to 12-8

V

Vacuum pump, 11-9 to 11-10
Visual inspection, 7-4

Vol-O-Flo calibration, 11-13
Vol-O-Flo element cleaning, 11-13
Vol-O-Flo elements, 11-4 to 11-6

W

Water, canned drinking, 5-4 to 5-5
Webbings and tapes, 10-4

Assignment Questions

Information: The text pages that you are to study are provided at the beginning of the assignment questions.

Assignment 1

Textbook Assignment: "Personnel Parachute Familiarization." Pages 1-1 through 1-30.

Learning Objective: Identify *principal events and persons related to the development of the parachute as the principal item of an aviator's personal survival equipment.*

- 1-1. The first man to be accredited with a successful parachute jump from an aircraft was
1. Jodaki Kuparento
 2. Fausto Veranzio
 3. Albert Berrv
 4. Andre Garnerin
- 1-2. Who was the first man to make a free-fall parachute jump from an aircraft?
1. Floyd Smith
 2. Guy Hall
 3. Major Hoffman
 4. Leslie Irvin
- 1-3. In what year did it become a mandatory requirement for all Navy aircrewmn to wear parachutes?
1. 1918
 2. 1922
 3. 1924
 4. 1923
- 1-4. In what year was the PR rate established?
1. 1922
 2. 1924
 3. 1942
 4. 1944
- 1-5. How many major components make up a standard service parachute?
1. Three
 2. Four
 3. Five
 4. Six
- 1-6. What is the air permeability of 1.1-ounce ripstop nylon?
1. 40 to 50 cubic feet per second
 2. 60 to 70 cubic feet per minute
 3. 70 to 80 cubic feet per second
 4. 80 to 100 cubic feet per minute
- 1-7. How many sections are in each gore of a 28-foot canopy?
1. Four
 2. Three
 3. Two
 4. One
- 1-8. The sections used in a parachute Canopy are cut at a 45-degree angle to the centerline of the gore. This is known as what type of construction?
1. Off-center
 2. Bias
 3. Filler
 4. Warp
- 1-9. Where can the date of manufacture be found on a 28-foot canopy?
1. Section D of gore 28
 2. Section C of gore 28
 3. Section A of gore 28
 4. Section B of gore 28

Learning Objective: Identify *basic criteria and associated functions, operating characteristics, and methods of parachute assembly.*

- 1-10. What part of a parachute prevents ruptures to the canopy during opening shock?
1. Vent hem
 2. Skirt hem
 3. Vent
 4. Gore
- 1-11. What size nylon thread should be used for sewing diagonal seams?
1. Either B or E
 2. F
 3. FF
 4. A
- 1-12. All machine stitching on a parachute canopy (except zigzag) should conform to (a) what type and (b) what federal standard?
1. (a) 301 (b) 750
 2. (a) 301 (b) 751
 3. (a) 302 (b) 750
 4. (a) 302 (b) 751
- 1-13. The overall length of a suspension line on a 28-foot canopy is
1. 14 ft 4 in
 2. 28 ft 8 in
 3. 56 ft 10 in
 4. 75 ft 4 in
- 1-14. What is the tensile strength of type III nylon suspension line?
1. 110 pounds
 2. 220 pounds
 3. 550 pounds
 4. 600 pounds
- 1-15. Which of the following components is NOT housed in a parachute container?
1. Harness
 2. Main canopy
 3. Suspension lines
 4. Pilot chute
- 1-16. Personnel parachute harness webbing has a tensile strength of
1. 4,000 to 5,000 pounds
 2. 6,000 to 7,000 pounds
 3. 6,000 to 8,000 pounds
 4. 4,000 to 5,000 pounds
- 1-17. How many types of parachute harnesses are used in the Navy?
1. One
 2. Two
 3. Three
 4. Four
- 1-18. Ripcord pins are swagged in place and tested at
1. 100 pounds
 2. 200 pounds
 3. 300 pounds
 4. 400 pounds
- 1-19. Parachute harness fittings are usually made of which of the following metals?
1. Cadmium plated steel
 2. Chrome plated steel
 3. Both 1 and 2 above
 4. Brass plated steel
- 1-20. What is the tensile strength of a V ring?
1. 1,000 pounds
 2. 1,500 pounds
 3. 2,000 pounds
 4. 2,500 pounds
- 1-21. How many types of adapters are used with parachutes?
1. One
 2. Two
 3. Three
 4. Four
- 1-22. Integrated torso harnesses equipped with SEAWARS are designed to automatically release the parachute risers upon Immersion in
1. fresh water only
 2. seawater only
 3. either fresh water or seawater
- 1-23. Several types of snaps used with parachutes include the plain-harness snap, quick-fit snap, and the quick-connector snap.
1. True
 2. False

- 1-24. A PR must not only know and observe the rules for handling parachutes, but he/she must be prepared to instruct squadron personnel in the specific DO's and DON'Ts of handling them.
1. True
 2. False
- 1-25. When placing an RFI parachute assembly into a shipping container, which of the following procedures should you perform?
1. Remove cartridges from all cartridge-actuated devices
 2. Chain the parachute suspension lines
 3. Release all snap fasteners
 4. All of the above
- 1-26. What is the total amount of naphthalene flakes that should be sprinkled throughout the parachute assembly prior to sealing it into a shipping container?
1. 1/4 pound
 2. 3/8 pound
 3. 1/2 pound
 4. 5/8 pound

Learning Objective; Recognize types of and criteria for parachute inspections; identify parachute assemblies to be inspected who inspects them, and how inspections are performed. Identify forms, symbols, and procedures used in inspecting parachute assemblies.

- 1-27. Changes and modifications to a parachute assembly can be issued by Aircrew Systems Bulletins, Aircrew Systems Changes, or updated material entered in which of the following manuals?
1. NAVAIR 13-1-6.1
 2. NAVAIR 13-1-6.2
 3. NAVAIR 13-1-6.3
 4. NAVAIR 11-100-1

- 1-28. After a parachute assembly is used in an emergency situation, what action is taken?
1. It is shipped to the Naval Weapons Center, China Lake, CA
 2. It is shipped to the Naval Air Development Center, Warminster, PA
 3. It is shipped to the Naval Safety Center, Norfolk, VA
 4. It is disposed of locally
- 1-29. Periodic maintenance for parachutes fall under the direction and control of the
1. shop supervisor
 2. quality assurance officer
 3. maintenance control officer
 4. maintenance officer
- 1-30. All parachute maintenance is done by the lowest level activity equipped to satisfactorily perform the work.
1. True
 2. False
- 1-31. Mission, time, equipment, trained personnel, and operational needs are not the basic considerations in determining which level performs maintenance on a parachute.
1. True
 2. False
- 1-32. Where do you record a 7-day or 14-day inspection performed on a parachute?
1. OPNAV Form 4790/38
 2. OPNAV 4790/101
 3. OPNAV 1348
 4. OPNAV 1030/8
- 1-33. How many pages make up a Parachute Configuration Inspection and History Record?
1. One
 2. Two
 3. Three
 4. Four

- 1-34. Who is responsible for initiating the Parachute Configuration Inspection and History Record?
1. The manufacturer
 2. The controlling custodians
 3. The IMA placing the parachute into service
 4. The squadron PR
- 1-35. All required entries on a Parachute Configuration Inspection and History Record must be legibly recorded using
1. a ball-point pen
 2. a typewriter
 3. either 1 or 2 above
 4. a felt-tip pen
- 1-36. Which copy of the parachute Configuration Inspection and History Record is filed with the aircraft logbook?
1. Hardback copy
 2. Pink copy
 3. Flimsy copy
 4. Yellow copy
- 1-37. Whenever a canopy is inspected and found to need repairs, what form is initiated?
1. A new Parachute Configuration Inspection and History Record
 2. A canopy Damage Chart
 3. A multlcopy MAF
 4. A NAVAIR-2650
- 1-38. The daily Inspection of a parachute installed in an aircraft can be performed by which of the following persons?
1. A pilot
 2. A plane captain
 3. A line troubleshooter
 4. Line personnel or issue room custodians found qualified by the PR and AME shops
- 1-39. Only parachutes installed in air-craft are Subject to a special (7-day or 14-day) inspection.
1. True
 2. False
- 1-40. a special inspection must include the harness used for that specific parachute inspected.
1. True
 2. False
- 1-41. If any damage or contamination is found or suspected while an inspection is being performed, who must the Inspector notify?
1. Line chief
 2. Duality assurance
 3. Work center supervisor
 4. Maintenance control
- 1-42. The original issue inspection on a parachute assembly is performed
1. every 14 days
 2. at each postcombat inspection
 3. at the time the assembly is placed into service
 4. at each calendar/phased inspection
- 1-43. A parachute has been used in an emergency situation. Which instruction gives you the procedures to follow to provide the Naval Weapons Center with sufficient information to properly evaluate the parachute?
1. NAVAIR 4790.2
 2. OPNAV 3750.6
 3. OPNAV 3710.7
 4. NAVAIR 1348
- 1-44. To meet unusual situations or facilitate workload schedulings how long can a parachute repack be delayed?
1. 7 days
 2. 10 days
 3. 14 days
- 1-45. Which of the following parts of a parachute assembly are required to be sent to the Naval Weapons Center (NWC) after use in an emergency?
1. Containers
 2. Harnesses
 3. Automatic parachute ripcord release assemblies
 4. All of the above

- 1-46. What is the maximum pull force on a ripcord pull test?
1. 22 pounds
 2. 25 pounds
 3. 27 pounds
 4. 36 pounds
- 1-47. What tool do you use to adjust the clip to meet the pull test requirements?
1. A screwdriver
 2. Pliers
 3. A ball peen hammer
 4. A setting maul
- 1-48. A pilot parachute in a parachute assembly will become averaged 1 month prior to the next inspection cycle. What action should be taken?
1. The parachute must be repacked 1 month early
 2. The parachute is taken out of service
 3. The parachute remains in service until the next repack cycle
 4. The pilot parachute must be replaced at the repack cycle prior to the expiration date
- 1-49. What action do you take if a cartridge becomes overaged prior to the next scheduled repack inspection?
1. The cartridge is replaced prior to repack
 2. The cartridge life may be extended to govern the inspection cycle
 3. The parachute must be repacked on the date the cartridge expires
- 1-50. If an emergency use canopy fails to show a start of service date, what will be the service life of the canopy from the date of manufacture?
1. 15 years
 2. 12 years
 3. 10 years
 4. 7 years
- 1-51. When you test for acid and/or alkaline contamination, what is the safe zone on pH test paper?
1. 0 to 5.0
 2. 5.0 to 9.0
 3. 9.0 to 14.0
 4. 14.0 to 20.0
- 1-52. What is the full range of pH test paper?
1. 0.0 to 8.5
 2. 0.0 to 9.0
 3. 0.0 to 10.0
 4. 0.0 to 14.0
- 1-53. What reading would indicate excess alkalinity?
1. 9.0 to 11.0
 2. 7.0 to 8.5
 3. 4.0 to 5.0
 4. 0.0 to 3.0
- 1-54. When inspecting suspension lines during an original issue inspection, how much tension is applied to the lines?
1. 5 pounds
 2. 10 pounds
 3. 15 pounds
 4. 20 pounds
- 1-55. When inspecting a parachute harness, you see a stencil on the horizontal backstrap that reads R-2-89. What does this information indicate?
1. The harness is to be removed from service in February 1989
 2. The harness was reworked February 1989
 3. The harness is a replacement harness, replaced in February 1989
 4. The harness is a regular size manufactured in February 1989
- 1-56. If fewer than three stitches are broken or loose on a harness assembly, what action, if any, should be taken?
1. Repair it using 6 cord
 2. Repair it using 3 cord
 3. Repair it using FF
 4. None

1-57. How many stitches per inch are used to sew a parachute harness?

1. 12 to 14
2. 10 to 12
3. 6 to 8
4. 4 to 6

1-58. What method is used to remove sand or dirt from canopy quick-release fittings?

1. High-pressure air (1500-1800 psi)
2. Low-pressure air (50 psi)
3. Toluene
4. Dry cleaning solvent

1-59. On most parachute containers that use rubber retaining bands to hold the suspension lines, the rubber bands must be replaced every

1. repack
2. other repack
3. third repack
4. fourth repack

1-60. When are local modifications permitted on a parachute assembly?

1. When directed by maintenance control
2. When directed by the maintenance officer
3. When directed by the squadron CO
4. When approved by proper authority

Assignment 2

Textbook Assignment: "Automatic Opening Devices," and "NES-12 Personnel Parachute System." Pages 2-1 through 2-15 and 3-1 through 3-15.

Learning Objective: *Recognize design requirements and component functions of the Model 7000 automatic parachute ripcord release assembly, and identify procedures pertinent to maintaining, inspecting, arming, and disarming it, including safety precautions to be observed.*

- 2-1. Working with an automatic parachute ripcord release assembly is the same as working with what loaded firearm?
1. .22-caliber pistol
 2. .38-caliber pistol
 3. .45-caliber pistol
 4. Shotgun
- 2-2. DELETED
- 2-3. While the firing mechanism is installed in a parachute, it is locked by which of the following parts?
1. The arming pin
 2. The sear
 3. The aneroid mechanism
 4. The locking pin
- 2-4. Before the preset altitude has been reached, the firing mechanism is prevented from firing by which component(s) of the release assembly?
1. The actuator stop
 2. The gear assembly lock
 3. The firing safety lock
 4. The aneroid and sear mechanism
- 2-5. What action results from the forward movement of the piston and its attached power cable?
1. The main powder charge in the cartridge explodes
 2. The arming cable is pulled below the preset altitude
 3. The aneroid sear releases the firing mechanism
 4. The locking pins are pulled and the parachute opening sequence begins
- 2-6. As the piston is forced forward in the barrel, the power cable travels what total number of inches?
1. 2.5 inches
 2. 2.0 inches
 3. 3.5 inches
 4. 3.75 inches
- 2-7. If any defect is found while inspecting a ripcord release assembly, what action should you take?
1. Salvage any workable parts from the assembly
 2. Affix a tag to the assembly denoting "NOT FOR USE"
 3. Remove and scrap the entire assembly
 4. Return the assembly to its manufacturer

- 2-8. What manual gives you information on the cartridge service life/total life?
1. NAVAIR 11-100-1.1
 2. NAVAIR 11-3710
 3. NAVAIR 11-13-1-6.9
 4. NAVAIR 11-10-100
- 2-9. Maintenance on any automatic ripcord release assembly in service must be performed at what times?
1. Every other time its parachute assembly is repacked
 2. Only at the original issue inspection
 3. Every time its parachute assembly is repacked
 4. Every third time its parachute assembly is repacked
- 2-10. What is the first step in performing the normal inspection and maintenance on an automatic ripcord release?
1. Remove the aneroid
 2. Disarm it
 3. Remove the power cable
 4. Remove the sear
- 2-11. All cover and power cable housings and the receiver and barrel assemblies have a serial number. If you find that a serial number for the cover housing has the same serial number as the receiver assembly, you should report this finding on an Unsatisfactory Material Condition Report.
1. True
 2. False
- 2-12. When inspecting the leaf springs you find that the tamper dot on the retaining screw is missing. You must torque the screw to what value?
1. 10 to 12 inch-pounds
 2. 12 to 14 inch-pounds
 3. 14 1/2 to 15 1/2 inch-pounds
 4. 15 to 16 inch-pounds
- 2-13. When you inspect the Teflon gasket seal, in what position should the cup side be facing?
1. The piston
 2. Away from the piston
 3. The aneroid seal
 4. The aneroid detector
- 2-14. The automatic parachute ripcord release test set has a test chamber that can withstand a vacuum equivalent to what altitude?
1. 20,000 feet
 2. 30,000 feet
 3. 40,000 feet
 4. 50,000 feet
- 2-15. Before using the test set, you must ensure it has what altimeter barometric pressure reading?
1. 29.29 inches
 2. 29.87 inches
 3. 29.90 Inches
 4. 29.92 inches
- 2-16. To test the firing of the automatic ripcord release, you must use a dummy cartridge; failure to use this cartridge may result in damage to the
1. firing pin
 2. arming pin
 3. firewall
 4. gasket seal
- 2-17. If you were going to test a ripcord release that is set to fire at 14,000±1,000 feet, you would run the test chamber to what altitude?
1. 15,000 feet
 2. 16,000 feet
 3. 18,000 feet
 4. 25,000 feet
- 2-18. By using the descent toggle, the test chamber will simulate a descent of how many feet per second?
1. 100 to 150
 2. 150 to 200
 3. 175 to 200
 4. 200 to 250

- 2-19. When you test the Model 7000 actuator, how many firing checks are made?
1. One
 2. Two
 3. Three
 4. Four

- 2-20. What color lacquer is used for the tamper dot on the locking screw?
1. Red
 2. Green
 3. White
 4. Orange

Learning Objective: *Recognize design requirements and component functions of the ballistic spreading gun, and identify procedures pertinent to maintaining, inspecting, and changing the cartridges.*

- 2-21. The spreader gun consists of how many slugs, pistons, and retainers?
1. 7
 2. 14
 3. 21
 4. 28

- 2-22. How is the cartridge installed in a spreader gun?
1. Threaded into the breech
 2. Loaded into the barrel assembly
 3. Loaded into a piston
 4. Threaded into a piston

- 2-23. What prevents accidental firing of the cartridge during handling?
1. A safety lanyard
 2. A safety cable
 3. A safety pin
 4. A safety lock

- 2-24. What holds the two lines and loop in the channels of each slug?
1. A rubber band
 2. A safety tie
 3. A rock washer
 4. A cover plate

- 2-25. When the cartridge fires, the slugs are propelled outward how many degrees?
1. 360
 2. 180
 3. 90
 4. 45

- 2-26. At a high-speed ejection, the spreading action of the slugs forms what size diameter mouth at the skirt hem?
1. 10 feet
 2. 8 feet
 3. 6 feet
 4. 4 feet

- 2-27. At a low-speed ejection, the spreading action of the slugs forms what size diameter mouth at the skirt hem?
1. 10 feet
 2. 8 feet
 3. 6 feet
 4. 4 feet

- 2-28. After the firing pin is withdrawn, the firing lanyard exerts how many pounds of tension on the fail-safe assembly sleeve?
1. 15 to 24 pounds
 2. 24 to 35 pounds
 3. 25 to 38 pounds
 4. 30 to 45 pounds

- 2-29. If the date the sealed container was opened is not available, the installed life of the cartridge is computed from the date of manufacture as determined from the lot number.
1. True
 2. False

- 2-30. The spreader gun cartridge is treated as what class ammunition?
1. A
 2. B
 3. C
 4. D

- 2-31. The lanyard retaining pin must be removed when replacing the upper retaining cord.
1. True
 2. False

- 2-32. If you have to remove a damaged or defective spreading gun, which of the following steps apply?
1. Slip all the suspension lines and attached loops from under the plates
 2. Disconnect the retaining cord from the vent lines
 3. Both 1 and 2 above
 4. Cut the retaining cord at the apex
- 2-33. When performing a firing pin release test, the pull force must be in what range?
1. 15 to 20 pounds
 2. 25 to 38 pounds
 3. 30 to 48 pounds
 4. 35 to 50 pounds
- 2-34. What is used to clean the cartridge chamber and threads of a spreading gun?
1. Denatured alcohol
 2. Dry-cleaning solvent
 3. WD-40
 4. Warm, soapy water
- 2-35. What is used to mark information on a spreading gun cartridge?
1. Red marking fluid
 2. Green marking ink
 3. White marking fluid
 4. Black marking ink
- 2-36. When a cartridge is properly installed into the chamber, the base of the cartridge should be in what approximate position in relation to the edge of the chamber?
1. Two threads above the top edge
 2. Even with the top edge
 3. Two threads below the bottom edge
 4. Even with the bottom edge
- 2-37. What is the torque value of the cartridge when it is placed into the chamber?
1. 97 ± 12 inch-pounds
 2. 70 ± 10 inch-pounds
 3. 54 ± 8 inch-pounds
 4. 84 ± 12 inch-pounds
-
- Learning Objective: *Recognize component functions and operating characteristics of the NES-12 personnel parachute system.*
-
- 2-38. When an aircrew member ejects from an aircraft, what causes the external pilot parachute to open?
1. The spreading gun
 2. The automatic ripcord release
 3. A static line
 4. The external pilot chute release assembly
- 2-39. At speeds up to 90 knots, the tristage pilot chute does which, if any, of the following?
1. Inflates fully
 2. Reduces to 18 inches
 3. Reduces to 24 inches
 4. None of the above
- 2-40. At speeds between 90 and 250 knots, the tristage pilot chute does which of the following?
1. It reduces in size to 18 inches
 2. It reduces in size to 24 inches
 3. It reduces in size to 30 inches
 4. It inverts
- 2-41. The suspension lines are pulled from the container by which of the following parachute components?
1. External pilot chute
 2. Spreading gun
 3. Internal pilot chute
 4. Main canopy
- 2-42. If the spreading gun fails to fire, what permits the canopy to open?
1. The slugs separate from the gun at full suspension line stretch
 2. The slugs have breakaway cover plates
 3. The override disconnect releases the slugs

- 2-43. The NES-12 personnel parachute system utilizes what type of canopy?
1. 26-foot
 2. 26-foot modified
 3. 20-foot modified
 4. 32-foot
- 2-44. The shoulder restraint system for the NES-12 is located on which of the following parachute assemblies?
1. Riser assembly
 2. Container assembly
 3. Harness assembly
-
- Learning Objective: *Identify procedures for inspecting, rigging, and packing the NES-12 parachute assembly.*
-
- 2-45. When a step is followed by "(QA)" in the rigging and packing procedure, all work stops until a quality assurance inspector performs the requirements listed at the end of the applicable procedures.
1. True
 2. False
- 2-46. How do you obtain a complete NES-12 parachute assembly to place into service?
1. Order the complete assembly
 2. Order each part separately
 3. Order a container and use spare parts to assemble a complete NES-12
- 2-47. If you are in the process of repacking a parachute and it is time to secure, what action must you take to complete the repacking procedures?
1. Complete the repack before you secure
 2. Secure and restart the procedure the next day from step one
 3. Either 1 or 2 above, depending upon the circumstances
 4. Lay a covering over the assembly and start at that step the next day
- 2-48. To attach the internal pilot parachute to the NES-12 assembly, you must use what type of knot(s)?
1. Bowline
 2. Square
 3. Clove hitch and a half hitch
 4. Larks head
- 2-49. When positioning the spreading gun for installation onto a parachute canopy, it is placed between which of the following suspension lines?
1. 1 through 14 and 15 through 28
 2. 1 through 28 and 14 through 15
 3. 21 through 7 and 28 through 8
 4. 7 through 14 and 28 through 21
- 2-50. To route the retaining cord through the main canopy, what, if anything, is used?
1. Type I suspension line
 2. Type II suspension line
 3. Type III suspension line
 4. Nothing
- 2-51. When positioning the spreading gun at the skirt hem, the gun should be rotated so that which labeled slug is facing up?
1. 28-1
 2. 14-13
 3. 12-13
 4. 1-28
- 2-52. What torque value is used to secure the slug plates to the spreading gun?
1. 5±1/2 pound-inches
 2. 7±1/4 pound-inches
 3. 10±1 pound-inches
 4. 6±1/2 pound-inches
- 2-53. What tool is used to push the sear into the barrel of the override disconnect?
1. A temporary locking pin
 2. A bodkin
 3. A straight slot screwdriver
 4. A jewelers wrench

- 2-54. The tacking that holds the override disconnect to the pilot parachute connector strap is tacked how far above the knot securing the connector strap to the vent lines?
1. 5±1/2 inches
 2. 4±1/2 inches
 3. 3±1/4 inches
 4. 2±1 inches
- 2-55. What type of thread/cord is used to tack the override disconnect to the pilot chute connector cord?
1. E thread
 2. FF thread
 3. 3-cord
 4. 6-cord
- 2-56. To stow the firing lanyard into the stowage sleeve, you must use what tool(s)?
1. A packing hook
 2. Type I nylon line and a bodkin
 3. Rubber bands
 4. Type III nylon line and a screwdriver
- 2-57. What size of thread is used to tack the second lanyard bight to the stowage sleeve?
1. A nylon thread
 2. E nylon thread
 3. F nylon thread
 4. FF nylon thread
- 2-58. Which of the following manuals would you use to ensure you are installing the proper arming cable and time-delay cartridge?
1. NAVAIR 13-1-6.5
 2. NAVAIR 13-1-6.4
 3. NAVAIR 13-1-6.3
 4. NAVAIR 13-1-6.2
- 2-59. The breakcords used to secure the lift web protector flaps over the risers are constructed from
1. three-strand cord
 2. four-strand cord
 3. FF thread
 4. E thread
- 2-60. What type of knots are used to secure the breakcords?
1. Lark's head
 2. Surgeon's knot and a square knot
 3. Two half-hitches
 4. Two half-hitches and a clove-hitch
- 2-61. The connector link ties are constructed from (a) how many lengths and (b) what type cord?
1. (a) Two 12-inch
(b) 100-pound nylon cord
 2. (a) Two 14-inch
(b) Type I cotton cord
 3. (a) Two 24-inch
(b) 150-pound nylon cord
 4. (a) TWO 16-inch
(b) Type III cotton cord
- 2-62. The loop used in the connector link ties is tied with what type knot(s)?
1. Overhand knot
 2. Lark's head knot
 3. Bowline and overhand knot
 4. Lark's head and overhand knot
- 2-63. When you install the release lanyard and ripcord assemblies, you must ensure that the baseplate clamp is in what position?
1. To the right of the hex nut locking pin
 2. Over the locking pin prior to installing the hex nut
 3. To the left of the hex nut locking pin
 4. Over the hex nut prior to installing the locking pin

2-64. When routing the firing lanyard through the lanyard guide grommet, where is the 36-inch mark on the lanyard placed?

1. Under the bar on the connector link
2. Over the bar on the connector link
3. Under the cross-connector strap
4. Over the cross-connector strap

2-65. When routing the firing lanyard through the suspension lines, it is routed between what lines?

1. 1 and 28
2. 14 and 15
3. 7 and 8
4. 16 and 15

Assignment 3

Textbook Assignment: "Aircrew Personal Protective Equipment," Pages 4-1 through 4-32.

-
- Learning Objective: *Maintain, repair, and make authorized modification to flight clothing?*
-
- 3-1. What is/are the primary function(s) of flight clothing?
1. Protection
 2. Comfort
 3. Appearance
 4. All of the above
- 3-2. What factor decides the difference between protection and comfort?
1. Aircraft design
 2. Operational condition
 3. Size of the aircrew member
 4. Type of material
- 3-3. Material that is used in the manufacture of flight clothing is designed to
1. lengthen service life
 2. provide comfort
 3. improve survival chances
 4. provide a nice appearance
- 3-4. Planned maintenance for flight clothing is performed at what level of maintenance
1. O level
 2. I level
 3. Depot level
 4. The level set forth in the OPNAVINST 4790.2
- 3-5. Flight clothing maintenance is divided into how many categories?
1. One
 2. Two
 3. Three
 4. Four
- 3-6. When you clean a helmet, what type of maintenance is being performed?
1. Calendar
 2. Corrective
 3. Phase
 4. Preventive
- 3-7. Who schedules preventive maintenance for all aircrew Personal protective equipment within a squadron?
1. Maintenance/material control officer
 2. Production control officer
 3. Shop chief
 4. Quality assurance
- 3-8. What is used to make entries on a maintenance document?
1. A blue pen
 2. A black pen
 3. A typewriter
 4. Any of the above
- 3-9. When signing a maintenance document you are required to perform which of the following actions?
1. Print your name
 2. Use your initials only
 3. Sign your full name
 4. Any of the above
- 3-10. What document is used to enter the equipment assigned to an aircrew member?
1. DD 1348
 2. Aircrew Personal Protective History Card
 3. NAVAIR 1348
 4. Form 4790/2E

- 3-11. The Aircrew Personal Protective Equipment History Card is divided into how many sections?
1. One
 2. Two
 3. Three
 4. Four
- 3-12. When you are working with personal protective equipment, which of the following NAVAIR manuals is most helpful?
1. 13-1-6.7
 2. 1-1-6.5
 3. 17-1-6.4
 4. 13-1-6.2
- 3-13. Who is the only authority that can authorize modification to survival equipment?
1. NMPC
 2. OPNAV
 3. COMFAIR
 4. NAVAIRSYSCOM
- 3-14. What field activity has cognizance over most life support and survival equipment?
1. NWC, China Lake, Ca
 2. NAVAIRDEVCON, Warminster, PA
 3. NAEC, Lakehurst, NJ
 4. NAEC, San Diego, CA
- 3-15. The field activity with cognizance over all survival radios and URT-33 emergency beacons is
1. NADEP, Pensacola
 2. NADEP, Jacksonville
 3. NAEC, Lakehurst
 4. NASC, Pensacola
- 3-16. If you are requested to sew a group of patches on a flight jacket, you would be allowed to sew up to how many square inches of patches?
1. 150 square inches
 2. 100 square inches
 3. 50 square inches
 4. There is no limit
- 3-17. The CWU-27/P and CWU-73/P summer flying coveralls are made from an Aramid cloth. This material will not support combustion, but will begin to char at what temperature?
1. 300° to 400°F
 2. 500° to 600°F
 3. 700° to 800°F
 4. 800° to 900°F
- 3-18. The CWU-27/P and CWU-73/P coveralls can be washed and dried in up to which of the following temperatures before damage or shrinkage occurs?
1. 100°F water and 120°F drying temperature
 2. 120°F water and 160°F drying temperature
 3. 110°F water and 140°F drying temperature
 4. 140°F water and 180°F drying temperature
- 3-19. The GS/FRP-2 flyer's gloves are available in how many sizes?
1. 6
 2. 7
 3. 8
 4. 9
- 3-20. After laundering a pair of GS/FRP-2 flyer's gloves, the proper way to remove excess water is to
1. squeeze them out
 2. wring them out
 3. place the gloves in a dryer
 4. drip dry them
- 3-21. Flyer's boots come in which of the following size ranges?
1. 6 regular through 16 wide
 2. 5 1/2 narrow through 15 1/2 narrow
 3. 4 narrow through 14 1/2 extra wide
 4. 5 1/2 wide through 13 regular

3-22. The SV-2B survival vest provides maximum storage for survival equipment. In addition, it provides for integration of which of the following items?

1. A life preserver
2. Anti-g coveralls
3. A chest-mounted oxygen regulator
4. All of the above

Learning Objective: *Identify requirements for wearing anti-exposure suits.*

3-23. Antiexposure suits must be worn in what maximum water temperature?

1. 32°F or below
2. 40°F or below
3. 50°F or below
4. 65°F or below

3-24. What maximum air temperature requires that antiexposure suits be worn?

1. 32°F or below
2. 40°F or below
3. 45°F or below
4. 50°F or below

Learning Objective: *Identify the characteristics of the A/P22P-6(V)2 and A/P22P-6A(V)2 antiexposure assemblies.*

3-25. The A/P22P series antiexposure assemblies are designed to be a

1. quick-donning type
2. continuous wear type
3. both 1 and 2 above

3-26. What is the only difference between the A/P22P-6(V)2 and the A/P22P-6A(V)2 antiexposure assemblies?

1. The type of coveralls
2. The type of material
3. The type of gloves
4. The type of liner

3-27. The antiexposure assemblies should be sized to aircrew members by using their

1. suit size
2. height, weight, and chest measurements
3. chest and height measurements
4. torso measurement.

3-28. The CWU-23/P liner is supplied in how many sizes?

1. 8
2. 10
3. 12
4. 14

3-29. The CWU-62/P antiexposure coverall is supplied in how many sizes?

1. 9
2. 10
3. 11
4. 12

3-30. If neck seal trimming is necessary, trimming increments should not be more than

1. one-eighth inch at a time
2. one-quarter inch at a time
3. one-half inch at a time
4. one inch at a time

3-31. SRU-25/P rubber socks selected based on the aircrew members boot size

1. True
2. False

3-32. When attaching the rubber socks to the antiexposure assembly, how many stitches per inch are used?

1. 2 to 6
2. 3 to 5
3. 5 to 7
4. 8 to 10

Learning Objective: *Maintain, repair, and place anti-g garments into service.*

- 3-33. How many G's can an average aircrew member withstand without the aid of an anti-g garment?
1. 4.5 to 5.5
 2. 6.0 to 7.0
 3. 6.5 to 7.5
 4. 10.0 to 12.0
- 3-34. DELETED
- 3-35. Which of the following g forces would have the most harmful effect on your body?
1. 2 g's for 1 minute
 2. 3 g's for 1 minute
 3. 6 g's for 3 minutes
 4. 12 g's for 1 second
- 3-36. The CSU-15/P anti-g garment is available in how many sizes?
1. 4
 2. 6
 3. 8
 4. 10
- 3-37. A preflight inspection on an anti-g garment is performed by the aircrew member before each flight. The interval between preflight inspections must not exceed how many days?
1. 2
 2. 7
 3. 10
 4. 14
- 3-38. A calendar inspection on the CSU-15/p anti-g garment is performed every
1. 180 days
 2. 91 days
 3. 60 days
 4. 30 days
- 3-39. When performing the leakage test on a CSU-15/P anti-g garment, the bladder is inflated to
1. 2 psi
 2. 3 psi
 3. 4 psi
 4. 5 psi
- 3-40. The anti-g suit bladder being tested should not lose more than how many psi in 30 seconds?
1. 1.0 psig
 2. 2.0 psig
 3. 3.0 psig
 4. 4.0 psig
- 3-41. Anti-g coveralls should be cleaned by
1. machine washing
 2. dry cleaning
 3. hand-washing in cold water
 4. hand-washing in hot water
- 3-42. The proper procedure for drying the anti-g garment is to
1. dry them in direct sunlight
 2. hang them on a wooden hanger in a dry, ventilated area
 3. tumble dry on gentle cycle
 4. wring them dry by hand
-
- Learning Objective: *Inspect, maintain, and fit integrated torso harnesses.*
-
- 3-43. The MA-2 torso harness integrates the aircrew member's
1. lap belt and seat pan only
 2. parachute harness and lap belt only
 3. parachute harness, lap belt, and shoulder harness
 4. lap belt and shoulder harness only
- 3-44. The MA-2 torso harness is available in how many sizes?
1. 10
 2. 12
 3. 14
 4. 16

- 3-45. Where is the gated D-ring attached to the MA-2 torso harness?
1. Left and right shoulders
 2. Right shoulder
 3. Left shoulder
 4. Cross-connector strap
- 3-46. Which of the following activities would you consult to determine if a custom made torso harness is necessary?
1. AIMD
 2. NETPMSA
 3. NAVAIRDEVCEEN
 4. Physiology unit
- 3-47. When fitting the MA-2 torso harness, the ideal location for the male kock fittings should be
1. in the hollow below the collar bone when the aircrew member is standing
 2. in the hollow below the collar bone when the aircrew member is sitting
 3. in the hollow below the collar bone when the aircrew member is sitting or standing
 4. two inches below the collar bone
- 3-48. How many types of inspections are performed on the MA-2 torso harness?
1. One
 2. Two
 3. Three
 4. Four
- 3-49. The calendar inspection must be done how often?
1. Once a month
 2. Every 210 days
 3. Every 61 days
 4. Each time the aircrew member s personal protective equipment is inspected
- 3-50. What is the service life of the MA-2 torso harness?
1. 12 years from the date placed in service
 2. 10 years from the date placed in service
 3. 15 years from the date placed in service
 4. 12 years from the date of manufacture
- 3-51. Where can you find the placed in Service date on a torso harness?
1. On the left leg strap
 2. On the right leg strap
 3. In the center of the lap belt strap
 4. In the center of the back strap
- 3-52. Which manual would you use to find detailed information on the Ma-2 torso harness?
1. NAVAIR 13-1-6.3
 2. NAVAIR 13-1-6.2
 3. NAVAIR 13-1-6.5
 4. NAVAIR 13-1-6.7
-
- Learning Objective: *Inspect, maintain, and fit protective helmets for aircrew members.*
-
- 3-53. How many different configurations can be made from the basic PRK-37/p helmet shell?
1. 10
 2. 12
 3. 15
 4. 17
- 3-54. Which of the following helmets is used in the S-3A aircraft?
1. HGU-43/P
 2. HGU-49/P
 3. HGU-46/P
 4. HGU-47(V)3/P
- 3-55. What is the designation of the single lens visor assembly?
1. AVG-8
 2. PRU-36/P
 3. EEK-3/P
 4. EEK-4A/P

- 3-56. The PRK-37/P helmet shells are available in how many sizes?
1. Three
 2. Four
 3. Five
 4. Six
- 3-57. Which of the following is recommended to clean the shell and edge roll of a helmet?
1. Ammonia and water
 2. Brillo pad
 3. Mild detergent and water
 4. Canopy polish
- 3-58. What percentage of a helmet must be covered with reflective tape?
1. 75 percent
 2. 80 percent
 3. 90 percent
 4. 100 percent
- 3-59. What colors are recommended for use when taping a helmet?
1. Green and red
 2. White and red
 3. Blue and white
 4. White and orange
- 3-60. The SPH-3C helmet is supplied in how many sizes?
1. Two
 2. Three
 3. Four
 4. Six
- 3-61. Liners for the SPH-3C helmet are provided in which of the following sizes?
1. 1/4 and 3/4 inch
 2. 1/2, 3/8, and 15/16 inch
 3. 1/4, 1/2, and 5/8 inch
 4. 1/2 and 3/4 inch
- 3-62. What percentage of visible light is transmitted in the neutral visor of a SPH-3C helmet assembly?
1. 3 to 5 percent
 2. 8 to 16 percent
 3. 20 to 30 percent
 4. 85 percent or greater
- 3-63. How often are protective helmets subjected to a calendar inspection?
1. Every 210 days
 2. Every 180 days
 3. Every 120 days
 4. Every 90 days
-
- Learning Objective: *Inspect, maintain, and fit the pressure-demand oxygen mask.*
-
- 3-64. The MBU-12/P oxygen mask will continue to function at a depth of
1. 10 feet underwater
 2. 12 feet underwater
 3. 16 feet underwater
 4. 20 feet underwater
- 3-65. How many different configurations can be made from the MBU-12/P oxygen mask?
1. Six
 2. Five
 3. Four
 4. Two
- 3-66. Which of the following manuals will give complete information on a MBU-12/P oxygen mask configuration buildup?
1. NAVAIR 13-1-6.4
 2. NAVAIR 13-1-6.7
 3. NAVAIR 00-80T-101
 4. NAVAIR 13-1-6.1
- 3-67. When fitting the mask to an aviator, how far are the bayonet fittings inserted into the receiver assembly?
1. Until it is snug
 2. To the first locking position
 3. To the third locking position
 4. To the second locking position
- 3-68. After adjusting the straps on the bayonet fittings you should tack them in place with
1. two turns of E thread
 2. one turn of E thread
 3. two turns of A thread
 4. one turn of FF thread

3-69. How often is a calendar inspection conducted on an oxygen mask?

1. 180 days
2. 90 days
3. 30 days
4. 60 days

3-70. The preferred solution for cleaning the oxygen mask is a mixture of 1/4 to 1/2 ounce of cleaning compound added to

1. 1 pint of water
2. 1 gallon of water
3. 2 gallons of water
4. 1 quart of water

3-71. To clean the inhalation/exhalation valve, you should use

1. Clorox and distilled water
2. benzalkonium chloride and distilled water
3. isopropyl alcohol and distilled water
4. either 2 or 3 above

Assignment 4

Textbook Assignment: "Rescue and Survival Equipment." Pages 5-1 through 5-22.

Learning Objective: *Inspect, maintain, and advise aircrew members on the use of rescue equipment and survival items.*

- 4-1. Survival items may be carried which of the following places?
1. Life rafts
 2. Droppable kits
 3. On the aircrewman
 4. All of the above
- 4-2. Which of the following manuals covers survival items?
1. NAVAIR 13-1-6.7
 2. NAVAIR 13-1-6.5
 3. NAVAIR 13-1-6.2
 4. NAVAIR 13-1-6.1
- 4-3. DELETED
- 4-4. How long does it take to exhaust a sea dye marker?
1. 1 hour
 2. 10 to 15 minutes
 3. 20 to 30 minutes
 4. 40 to 50 minutes
- 4-5. The dye marker ceases to be a good target after being dispersed for approximately what period of time?
1. 1 hour
 2. 2 hours
 3. 45 minutes
 4. 30 minutes
- 4-6. How far can the dye marker be seen from an altitude of 3,000 feet?
1. 3 miles
 2. 5 miles
 3. 8 miles
 4. 10 miles
- 4-7. The signaling mirror can produce a light the equivalent of how many candlepower?
1. 6,000,000
 2. 8,000,000
 3. 10,000,000
 4. 11,000,000
- 4-8. On a bright sunny day, the flashes from a signal mirror can be seen from a distance of
1. 10 miles
 2. 20 miles
 3. 40 miles
 4. 50 miles
- 4-9. The Mk 79 Mod 0 signal kit is supplied with what total number of Mk 80 Cartridges?
1. 7
 2. 8
 3. 10
 4. 12
- 4-10. When fired, each cartridge flare has a minimum duration of
1. 4 seconds
 2. 4 1/2 seconds
 3. 5 seconds
 4. 5 1/2 seconds
- 4-11. How many feet will the Md 80, signal flare travel when it is launched?
1. 100
 2. 150
 3. 200
 4. 250

- 4-12. The Mk 13, Mod 0 signal flare will burn for approximately what maximum period of time?
1. 10 seconds
 2. 20 seconds
 3. 30 seconds
 4. 40 seconds
- 4-13. The lot number of the flare should be checked each time the flare is inspected. The lot numbers of flares that are not serviceable can be found in which of the following publications?
1. NAVAIR 13-1-6.5
 2. Cut-rent aircrew equipment bulletins
 3. NAVAIR 11-15-7
 4. Current revisions to the NAVAIR 13-1-6.7
- 4-14. Which of the following distress signals is commonly called a strobe light?
1. SL-5/E
 2. LT-65
 3. SLT-73/E
 4. SDU-5/E
- 4-15. You are required to inspect the SDU-5/E distress light a minimum of how often?
1. Every 30 days
 2. Every 60 days
 3. Every 90 days
 4. Every 120 days
- 4-16. The SDU-5/E distress light is required to flash how many times per minute for a 2-minute duration?
1. 50 ± 10
 2. 40 ± 5
 3. 30 ± 10
 4. 20 ± 5
- 4-17. The SRU-31/P survival kit consists of two parts. What person/activity is responsible for the medical items in packet number one?
1. The squadron supply officer
 2. The local medical department.
 3. The squadron PR
 4. The aircrew member
- 4-18. The eye ointment that is carried in the SRU-31/P survival kit has an expiration date of
1. 7 years
 2. 2 years
 3. 3 years
 4. 5 years
- 4-19. What is the purpose of the rations that are carried by aircrew personnel?
1. To provide subsistence
 2. To alleviate thirst
 3. To provide nourishment
 4. To provide quick energy, only
- 4-20. An emergency drinking water can contains what total amount of water?
1. 6 ounces
 2. 8 ounces
 3. 10 ounces
 4. 12 ounces
- 4-21. The shelf life and the service life of canned water is indefinite, as long as the cans pass what test?
1. Slap test
 2. Leakage test
 3. Pressure test
-
- Learning Objective: *Test and maintain survival radios.*
-
- 4-22. The AN/PRC-63 radio set has how many modes of operations?
1. One
 2. Two
 3. Three
 4. Four
- 4-23. Which of the following modes of operation is NOT used in the operation of the AN/PRC-63?
1. Beacon
 2. Voice transmission
 3. Voice reception
 4. Automatic SOS

- 4-24. What feature of the AN/PRC-63 radio will let the aircrew member know that his radio is putting out a signal?
1. A beacon confidence tone
 2. A toggle switch
 3. A micro-transceiver
 4. A red light
- 4-25. The AN/PRC-63 radio has a voice communication range of up to approximately what distance?
1. 10 miles
 2. 25 miles
 3. 50 miles
 4. 75 miles
- 4-26. A search aircraft flying at 10,000 feet can locate a transmitting beacon up to approximately what distance?
1. 25 miles
 2. 50 miles
 3. 70 miles
 4. 80 miles
- 4-27. The lanyard attached to the deployment device on the AN/PRC-63 radio must be able to withstand a pull of what minimum amount?
1. 20 pounds
 2. 25 pounds
 3. 50 pounds
 4. 110 pounds
- 4-28. When transmitting on the AN/PRC-63 radio, where should the radio be held?
1. Next to the mouth and at a 43° angle
 2. Two inches from the mouth at a 45° angle
 3. Next to the mouth and upright
 4. One to two inches from the mouth and upright
- 4-29. To increase the receiving sound on your AN/PRC-63, what should you do?
1. Turn the volume control clockwise
 2. Turn the volume counterclockwise
 3. Turn the beacon selector to "loud"
 4. Turn the beacon selector to "loudest"
- 4-30. Which of the following units is used to test the operation of the AN/PRC-63?
1. AN/PRC-63T
 2. AN/PRC-36T
 3. AN/PRC-90
 4. AN/PRM-32
- 4-31. Which of the following publications would you use to find information on the testing procedures for the AN/PRC-90 radio?
1. NAVAIR 13-1-6.5
 2. NAVAIR 13-1-6.7
 3. NAVAIR 16-30PRC90-2
 4. NAVAIR 16-30PRC63-1
- 4-32. What is the shelf/service life of the Mallory battery used in the AN/PRC-63 radio?
1. 36 months from the date of manufacture
 2. 24 months from the date of manufacture
 3. 36 months from the date placed in service
 4. 24 months from the date placed in service
- 4-33. Under ideal conditions, the AN/PRC-90 radio has a maximum voice range of how many nautical miles?
1. 100
 2. 75
 3. 60
 4. 50
- 4-34. The tone (code signal) on the AN/PRC-90 radio has a maximum range of how many nautical miles?
1. 50
 2. 80
 3. 90
 4. 100
- 4-35. The shelf life of a battery is based on storage temperature. What is this temperature?
1. 40°F
 2. 50°F
 3. 60°F
 4. 70°F

Learning Objective: *Identify specifications and performance capabilities of survival radios.*

4-36. To place the AN/PRC-90 radio on a guard channel beacon operation, you would set the function to

1. MCW-137.0
2. BCN-243.0
3. ABC-252.0
4. CBA-243.0

4-37. Which of the following radios is strictly a beacon radio set?

1. AN/PRC-32A
2. AN/PRC-63
3. AN/URT-33A
4. AN/URT-63

4-38. What is the storage life of a battery used in the AN/URT-33A?

1. 12 months at 60°F
2. 18 months at 90°F
3. 24 months at 70°F
4. 36 months at 70°F

4-39. When the AN/PRT-5 is activated, it will send out signals on which of the following frequencies?

1. 83.64 MHz
2. 843.6 and 234.0 MHz
3. 2.430 MHz
4. 8.364 and 243.0 MHz

4-40. At 77°F the battery pack for the AN/PRT-5 is designed to give continuous operation for

1. 48 hours
2. 60 hours
3. 72 hours
4. 96 hours

Learning Objective: *Identify the construction and characteristics of helicopter rescue equipment such as the survivors sling and the rescue seat.*

4-41. For information on search and rescue procedures at sea you would refer to what publication?

1. OPNAV 4790.2
2. NAVAIR 80T-101
3. NWP 19-1
4. OPNAV 3710.7

4-42. A survivor should never touch a rescue device until it has touched the ground or water for what reason?

1. The device must be stopped first
2. The device has to be grounded to prevent electrical shock
3. This will ensure the device will not release unexpectedly
4. The survivor must be sure the helicopter is on the proper wind line

4-43. The survivor's sling is constructed with what type filling?

1. Kapok
2. Styrofoam
3. Foam rubber
4. Polyurethane

4-44. The survivor's sling is identified by what color(s)?

1. Red
2. Orange and white
3. Yellow
4. Red and white

4-45. The rescue sling is designed to carry how many people at one time?

1. One
2. Two
3. Three

4-46. The calendar inspection on the rescue sling is performed at intervals not to exceed how many days?

1. 60 days
2. 90 days
3. 120 days
4. 225 days

- 4-47. When testing the survivor's sling on a webbing tester what load is applied to the sling?
1. 300 pounds
 2. 500 pounds
 3. 600 pounds
 4. 1,000 pounds
- 4-48. The rescue seat has (a) what total number of prongs and (b) the prongs are how many degrees apart?
1. (a) 2 (b) 180°
 2. (a) 3 (b) 120°
 3. (a) 4 (b) 90°
- 4-49. If the rescue seat has been immersed in salt watery it must be cleaned with
1. solvent
 2. gasoline
 3. mild soap and water
 4. a special chemical mixture
-
- Learning Objective: *Identify the operational characteristics of the forest penetrator and rescue net.*
-
- 4-50. The forest penetrator is a compact rescue device that has what approximate weight?
1. 10 1/2 pounds
 2. 12 pounds
 3. 21 1/2 pounds
 4. 25 pounds
- 4-51. How long are the safety straps the forest penetrator?
1. 4 feet 9 1/4 inches
 2. 5 feet 9 inches
 3. 6 feet
 4. 8 feet
- 4-52. With the flotation collar installed, how far above the surface of the water will the forest penetrator float?
1. 5 inches
 2. 2 inches
 3. 6 inches
 4. 4 inches
- 4-53. The forest penetrator is designed to accommodate up to how many survivors at a time?
1. One
 2. Two
 3. Three
 4. Four
- 4-54. All forest penetrators are subjected to a calendar inspection every
1. 60 days
 2. 90 days
 3. 181 days
 4. 223 days
- 4-55. When you perform a calendar inspection on the forest penetrator, you must compare the markings on it and the markings on the flotation collar. What manual would you use to ensure they are the applicable markings?
1. NAVAIR 13-1-6.5
 2. NAVAIR 13-1-6.7
 2. NAVAIR 00-80T-101
 4. NAVAIR NWP-19-1
- 4-56. How many pounds does the rescue net weigh?
1. 10 pounds
 2. 20 pounds
 3. 30 pounds
 4. 37 pounds
- 4-57. How long is the sea anchor retaining line on the rescue net?
1. 10 feet
 2. 12 feet
 3. 15 feet
 4. 20 feet
- 4-58. During moderate seas the sea anchor should be attached to the rescue net so that it will extend how far?
1. 20 feet.
 2. 15 feet
 3. 10 feet
 4. 5 feet
-
- Learning Objective: *Conduct period inspections and test of rescue harnesses, rescue hooks, and cattle cutters.*
-

- 4-59. A calendar inspection is performed on the rescue harness a minimum of how often?
1. Every 60 days
 2. Every 90 days
 3. Every 210 days
 4. Every 225 days
- 4-60. The service life of the rescue harness is 7 years from the date it was placed into service, but it is NOT to extend beyond what length of time from the date of fabrication?
1. 8 1/2 years
 2. 9 years
 3. 10 years
 4. 12 years
- 4-61. If a service date cannot be determined, the rescue harness must be removed from service what maximum number of years from the date of manufacture?
1. 5
 2. 7
 3. 8 1/2
 4. 10
- 4-62. When you clean the rescue harness, the water must not exceed what temperature?
1. 90°F
 2. 100°F
 3. 120°F
 4. 150°F
- 4-63. The large rescue hook will support how much weight?
1. 1,500 pounds
 2. 2,000 pounds
 3. 2,500 pounds
 4. 3,000 pounds
- 4-64. The smaller rescue hook supports what maximum weight?
1. 500 pounds
 2. 1,000 pounds
 3. 2,500 pounds
 4. 2,000 pounds
- 4-65. The ring will support what maximum weight?
1. 500 pounds
 2. 1,000 pounds
 3. 1,500 pounds
 4. 2,000 pounds
- 4-66. The hoist quick-splice plate is used under which of the following conditions?
1. When the hoist cable is cut or broken
 2. When time is a factor
 3. When no other means is available for rescue
 4. All of the above
- 4-67. The cable grip is an emergency condition device that is capable of supporting what maximum weight?
1. 1,000 pounds
 2. 1,500 pounds
 3. 2,000 pounds
 4. 2,500 pounds
- 4-68. The pneumatic rescue hand tool operates on a nitrogen gas cylinder with a pressure of
1. 1,000 psi
 2. 2,000 psi
 3. 3,000 psi
 4. 3,500 psi
- 4-69. The hand tool can cut stainless steel cable of what maximum diameter?
1. 1/8 inch
 2. 1/4 inch
 3. 5/8 inch
 4. 7/32 inch
- 4-70. To pass the trigger force test, the hand tool trigger force must be in what range?
1. 2 and 5 pounds
 2. 5 and 20 pounds
 3. 20 and 25 pounds
 4. 25 and 27 pounds
- 4-71. After cleaning the hand tool, you should lightly coat the cutting edge of the blade with what?
1. Light weight oil
 2. Bearing grease
 3. Pneumatic grease
 4. Heavy weight oil

Assignment 5

Textbook Assignment: "Inflatable Survival Equipment." Pages 6-1 through 6-35.

- Learning Objective: *Recognize life raft construction materials design features, stowage locations, and configurations; identify inflation procedures; and describe repair requirements for life rafts.*
- 5-1. All inflatable survival equipment is subjected to periodic maintenance under the direction of the
1. maintenance/material control officer
 2. maintenance chief
 3. work center supervisor
 4. quality assurance officer
- 5-2. To meet unusual situations, the calendar inspections on inflatable equipment may be extended up to what maximum number of days?
1. 5 days
 2. 7 days
 3. 10 days
 4. 14 days
- 5-3. For aircraft that are in phase maintenance, the time extended for periodic maintenance can be extended to plus or minus what percent of the time cycle?
1. 5
 2. 10
 3. 15
 4. 20
- 5-4. Life rafts installed in the fuselage require a daily inspection. This inspection can be performed by which of the following persons?
1. The plane captain (designated and instructed)
 2. The aircrew member (designated and instructed)
 3. The PR
 4. All of the above
- 5-5. DELETED
- 5-6. How often is a functional test performed on a life raft?
1. Every inspection
 2. Every other inspection
 3. Every third inspection
 4. Every fourth inspection
- 5-7. When you are performing a functional test, the life raft should inflate to its designed shape in less than what maximum amount of time?
1. 1 minute
 2. 2 minutes
 3. 3 minutes
 4. 30 seconds
- 5-8. When applying a pull cable proof load test, how many pounds of force must be applied?
1. 25
 2. 30
 3. 50
 4. 75
- 5-9. Which of the following life rafts can be inflated by using an oral inflation tube?
1. LR-1
 2. LRU-12/A
 3. LRU-13/A
 4. LRU-15/A

- 5-10. Before you test the pressure in a flotation compartment during a leakage test, you must wait a minimum of how many hours after the final pressure adjustment is made?
1. 8
 2. 2
 3. 24
 4. 4
- 5-11. To clean a life raft you would use a cleaning compound mixed with water. This mixture should consist of one part of compound to how many parts of water?
1. Six
 2. Five
 3. Three
 4. Four
- 5-12. CO₂ cylinders for multiplace life rafts are subjected to a hydrostatic test a minimum of how often?
1. Yearly
 2. Every 2 years
 3. Every 3 years
 4. Every 5 years
- 5-13. When installing an inflation valve onto a CO₂ cylinder that will be used on a multiplace life raft, you would torque it to how many inch-pounds?
1. 400±40
 2. 600±60
 3. 800±80
 4. 900±90
- 5-14. What is the hydrostatic test interval, if any, for an LR-1 life raft cylinder?
1. None
 2. 2 years
 3. 5 years
 4. 4 years
- 5-15. CNO has established that life rafts will carry enough equipment for an aircrew member to be capable of surviving for how long?
1. 12 hours
 2. 24 hours
 3. 72 hours
 4. 96 hours
- 5-16. When repairing a loose or missing seam tape, you must overlap the seam tape on other seams at least how many inches?
1. 1
 2. 1/2
 3. 3
 4. 4
- 5-17. What is recommended to remove or loosen damaged tape on a life raft?
1. Cleaning compound
 2. Toluene
 3. Gasoline
 4. M.E.K.
- 5-18. How many coats of toluene are applied to an area that you are going to repair?
1. One
 2. Two
 3. Three
 4. Four
- 5-19. How many coats of cement are applied to the raft when you make a repair?
1. One
 2. Two
 3. Three
 4. Four
- 5-20. When applying cement to a patch, how long should you wait between the first and the last coat?
1. 10 minutes
 2. 15 minutes
 3. 20 minutes
 4. 25 minutes
- 5-21. How long must you wait before applying talcum powder to the patch area?
1. 12 hours
 2. 24 hours
 3. 36 hours
 4. 48 hours
- 5-22. You must scallop the edge of a patch that is larger than what maximum size?
1. 6 inches
 2. 2 inches
 3. 3 inches
 4. 5 inches

5-23. Righting handles are provided on all life rafts EXCEPT which of the following?

1. LRU-12/A
2. LRU-13/A
3. LRU-14 series
4. LRU-15/A

5-24. Topping-off valves on multiplace life rafts are used in conjunction with the

1. oral Inflation tube
2. hand pump
3. CO₂ manifold
4. internal bulkheads

5-25. The LRU-13/A life raft is designed to hold what maximum number of people?

1. 13
2. 7
3. 5
4. 4

5-26. Life rafts that are stowed inboard on aircraft are secured to the aircraft by which of the following methods?

1. A painter line
2. A life line
3. A securing line
4. A mooring line

5-27. What is the static breaking strength of the line used to secure a life raft to an aircraft?

1. 10 to 20 Pounds
2. 20 to 40 pounds
3. 30 to 50 pounds
4. 30 to 150 pounds

5-28. The LRU-14 series raft is designed to hold what maximum number of aircrew members?

1. 14
2. 12
3. 7
4. 4

5-29. What unique design feature does the LRU-15/A raft have over other multiplace rafts?

1. It carries an outboard motor
2. It is always right side up after it's inflated
3. It has a punctureproof flotation tube
4. It can be used as a sailboat

5-30. If an LRU-14 series life raft fails to inflate with CO₂, the aircrew member should be taught to use the hand pump to inflate which part of the life raft first?

1. The floor
2. The main flotation tube
3. The spray tube
4. The seat

5-31. How long is the retaining line on a LR-1 life raft?

1. 8 feet
2. 6 1/2 feet
3. 5 feet
4. 4 feet

5-32. DELETED

Learning Objective: *Recognize types, operating principles, design features, and maintenance requirements of life preservers, and identify the components, their purposes, capabilities, configurations, and lifesaving applications.*

5-33. The LPU-21/P series life preserver is intended for use in aircraft that are equipped with ejection seats.

1. True
2. False

- 5-34. What is the weight of the LPU-21/P series life preserver without survival equipment?
1. 5.0 pounds
 2. 4.5 pounds
 3. 3 pounds
 4. 4 pounds
- 5-35. When properly inflated, the LPU-21/P series life preserver provides the wearer with a minimum buoyancy of
1. 40 pounds
 2. 60 pounds
 3. 65 pounds
 4. 70 pounds
- 5-36. The LPU-21/P series life preserver has how many flotation chambers?
1. One
 2. Two
 3. Three
 4. Four
- 5-37. The webbing belt on the LPU-21/P series life preserver provides for waist size adjustment in what range?
1. 28 to 34 inches
 2. 30 to 42 inches
 3. 40 to 46 inches
 4. 30 to 44 inches
- 5-38. Which of the following aircrew members would wear an LPU-25/P series life preserver?
1. A P-3 PPC
 2. An H-46 crew chief
 3. An F-14 pilot
 4. A C-130 flight engineer
- 5-39. Which of the following is the primary means of inflating an LPU-23/P series life preserver?
1. The FLU-8A/P automatic inflation device
 2. Pulling the beaded handles
 3. Firing the SEAWARS system
 4. Actuating the explosives primer
- 5-40. How many times can the FLU-8A/P inflator be used before it must be replaced?
1. One
 2. Two
 3. Three
 4. Four
- 5-41. Which of the following life preservers would be used by a passenger on a cargo-type aircraft?
1. LPU-21/P
 2. LPU-24/P
 3. LPA-2
 4. LPP-1A
- 5-42. What is the only difference between the LPP-1 and the LPP-1A life preservers?
1. The size
 2. The inflation assembly
 3. The shape
 4. The automatic inflation device
- 5-43. The LPP-1/1A life preservers provide a minimum of how many pounds of buoyancy to the user?
1. 21
 2. 29
 3. 32
 4. 39
- 5-44. The LPP-1/1A adjusts to fit waist sizes in what range?
1. 28 to 40 inches
 2. 28 to 42 inches
 3. 30 to 46 inches
 4. 30 to 52 inches
- 5-45. The CO₂ cylinder used with the LPP-1A has a charge of how many grams?
1. 25 to 28
 2. 26 to 29
 3. 28 to 31
 4. 30 to 33
- 5-46. The protective cover used with the LPU-30/P life preserver is supplied in how many sizes?
1. One
 2. Two
 3. Three
 4. Four

- 5-47. How is the LPU-30/P life preserver inflated?
1. By pulling the inflation lanyard
 2. By using an FLU-8A/P assembly
 3. By pulling the beaded handles
- 5-48. Life preservers that are installed in an aircraft are subject to a special inspection. This inspection must NOT exceed how many days?
1. 14
 2. 30
 3. 180
 4. 231
- 5-49. Personnel issue life preservers are on a calendar/phase inspection cycle of how many days?
1. 30
 2. 60
 3. 90
 4. 181
- 5-50. A functional test is performed on life preservers a minimum of how often?
1. Every 90 days
 2. Every 180 days
 3. Every third inspection
 4. Every fourth inspection
- 5-51. When performing a functional test on a life preserver, it should inflate fully to its designed shape in less than what maximum number of seconds?
1. 30
 2. 40
 3. 60
 4. 90
- 5-52. If it is necessary to readjust the pressure in a life preserver when you are doing a leak test, how many minutes should you wait after the air supply has been shut off?
1. 3
 2. 10
 3. 15
 4. 20
- 5-53. After the life preserver pressure has stabilized, how many hours must you wait before the pressure is recorded?
1. 1
 2. 2
 3. 3
 4. 4
- 5-54. What is the maximum allowable pressure drop in an LPU-30/P life preserver after a period of 4 hours?
1. 0.1 psi
 2. 0.2 psi
 3. 0.3 psi
 4. 0.4 psi
- 5-55. To perform the visual inspection, you would inflate the life preserver to how many psi?
1. 1
 2. 2
 3. 3
 4. 4
- 5-56. What indication do you look for to ensure that the automatic inflation feature of a LPU-23/P life preserver is in tact?
1. The silver indicator will be visible
 2. The firing check port will be open
 3. The silver indicator will not be visible
 4. The firing check port will be closed
- 5-57. What is the service life of the FLU-8/P series automatic inflator from the date of manufacture?
1. 12 months
 2. 24 months
 3. 48 months
 4. 66 months
- 5-58. DELETED

- 5-59. When performing a battery voltage test on an LPU-24/P series life preserver, you would use a needle type voltage multimeter?
1. True
 2. False
- 5-60. How long should you wait for the FLU-8A/P circuit to stabilize before you take the voltage readings?
1. 10 seconds
 2. 15 seconds
 3. 20 seconds
 4. 25 seconds
- 5-61. What would a reading of -12 indicate when performing a battery voltage test?
1. The battery is installed backwards
 2. The battery is dead
 3. Both batteries are dead
 4. The voltage meter is on the wrong setting
- 5-62. How many times do you operate the beaded inflation handles to ensure the piercing pin moves properly?
1. Two or three
 2. Three or four
 3. Five or six
 4. Eight
- 5-63. How much pressure is applied to the actuating lanyard of a LPP-1/1A series life preserver when you perform an initiation lanyard pull test?
1. 10 pounds
 2. 15 pounds
 3. 20 pounds
 4. 25 pounds
- 5-64. What is used to clean the threads on a CO₂ cylinder?
1. A wire brush
 2. A thread chaser die
 3. A jeweler's file
 4. A soft cloth
- 5-65. To ensure a firm cylinder seat, the cylinder must have a minimum of how many threads?
1. 5
 2. 6
 3. 7
 4. 8
- 5-66. Before you replace a CO₂ cylinder, you must ensure that it is no less than how many grams of its minimum stamped weight?
1. 1
 2. 2
 3. 3
 4. 4
- 5-67. How much force is used to torque the sensor plug cap on an FLU-8A/P?
1. 5 inch-pounds
 2. 6 inch-pounds
 3. 7 inch-pounds
 4. 8 inch-pounds

Assignment 6

Textbook Assignments: "Seat Survival Kit," pages 7-1 through 7-9; and "Carbon Dioxide," pages 8-1 through 8-5.

-
- Learning Objective: *Identify, inspect, and maintain the RSSK-8 seat survival kit.*
-
- 6-1. Which portion of the RSSK-8 container houses the emergency oxygen supply?
1. The seat cushion
 2. The upper container
 3. The survival kit unit
 4. The lower container
- 6-2. The release handle is located on which area of the RSSK-8?
1. The rear left side
 2. The forward left side
 3. The forward right side
 4. The rear right side
- 6-3. Oxygen from the emergency oxygen system is prevented from flowing into the aircraft O₂ system by the
1. aircraft O₂ pressure
 2. poppet valve
 3. check valve in the O₂ mask
 4. check valve in the O₂ line
- 6-4. If the automatic actuation lanyard fails to actuate the emergency oxygen system, the aircrew member can operate it manually by pulling the
1. yellow "O" ring
 2. green knob
 3. green ring
 4. yellow release handle
- 6-5. A hard landing would warrant which of the following inspections on a seat kit?
1. A conditional
 2. An SDLM
 3. A turnaround
 4. A postflight
- 6-6. Which of the following activities is responsible for doing a 7- or 14-day inspection on a survival kit installed in an aircraft?
1. QA division
 2. Aircraft division
 3. Aviator's equipment branch
- 6-7. When performing a daily inspection on an RSSK-8, you discover the seal decal is torn. What action, if any, would you take?
1. Notify maintenance control
 2. Replace the torn decal
 3. Notify QA
 4. None
- 6-8. On the RSSK-8 survival kit, similar parts from kits made by different manufacturers are interchangeable.
1. True
 2. False
- 6-9. What is the maximum time that can elapse between phase inspections on a seat kit?
1. 91 days
 2. 182 days
 3. 225 days
 4. 231 days
- 6-10. To perform the swaged ball pull test, the swaged ball should withstand a pull force of how many pounds?
1. 50
 2. 100
 3. 150
 4. 200

- 6-11. When performing the swaged ball pull test, you must ensure that the links and clevis are not pulled from the housing more than what maximum distance?
1. 1/2 in
 2. 1 in
 3. 1 1/2 in
 4. 2 in
- 6-12. What is the ideal temperature in an oxygen shop when a functional test is performed on a seat kit?
1. 65°F
 2. 70°F
 3. 72°F
 4. 75°F
- 6-13. To perform a functional test on a seat kit, the O₂ system should have a pressure reading of how many psi?
1. 1,200 to 1,400
 2. 1,400 to 1,600
 3. 1,600 to 1,800
 4. 1,800 to 2,000
- 6-14. When you test the manual emergency oxygen release handle, what should be the disengagement force for the handle?
1. 5 to 20 pounds
 2. 10 to 30 pounds
 3. 20 to 40 pounds
 4. 30 to 50 pounds
- 6-15. When testing the relief valve on the RSSK-8 emergency O₂ system, at what pressure range should the valve unseat?
1. 10 to 30 psi
 2. 70 to 90 psi
 3. 90 to 110 psi
 4. 120 to 140 psi
- 6-16. The relief valve should reset at a minimum of how many psi?
1. 30
 2. 90
 3. 110
 4. 120
- 6-17. Purging the emergency O₂ system is required when the system meets which of the following criteria?
1. Falls below 5 psi
 2. Falls below 15 psi
 3. Has remained empty for less than 2 hours
 4. Has remained empty for more than 2 hours
- 6-18. To release pressure in the oxygen bottle before purging, the pressure should be released through the filler valve.
1. True
 2. False
- 6-19. To purge an oxygen system, you should use nitrogen that is heated to a temperature range of how many degrees?
1. 180° to 200°F
 2. 220° to 230°F
 3. 230° to 266°F
 4. 260° to 276°F
- 6-20. When charging an O₂ system, each filling stage should take at least
1. 5 minutes
 2. 2 minutes
 3. 3 minutes
 4. 4 minutes
- 6-21. A cooling period of how long is required between each filling stage?
1. 1 minute
 2. 2 minutes
 3. 3 minutes
 4. 4 minutes
- 6-22. If a seat kit is to be stored, a pressure of how many psi should remain in the O₂ system?
1. 200
 2. 500
 3. 900
 4. 1,200
- 6-23. When recharging a seat kit, how many psi of oxygen is supplied between stages 3 and 4?
1. 100
 2. 200
 3. 300
 4. 400

Learning Objective: *Inspect and recharge CO₂ cylinders.*

- 6-24. What color, if any, is CO₂?
1. Pale gray
 2. Dark gray
 3. Pale blue
 4. Colorless
- 6-25. A standard supply cylinder will contain how many pounds of CO₂?
1. 10
 2. 40
 3. 50
 4. 80
- 6-26. In its gaseous form, CO₂ is how many times heavier than air?
1. 1.50
 2. 1.53
 3. 1.60
 4. 1.63
- 6-27. At a temperature of 72°F, CO₂ gas can be converted into a liquid by applying a pressure of how many psi?
1. 400
 2. 500
 3. 600
 4. 700
- 6-28. Depending on temperature and pressure, CO₂ can take on how many different forms?
1. One
 2. Two
 3. Three
 4. Four
- 6-29. In its dry ice form, CO₂ has what temperature?
1. -32°F
 2. -40°F
 3. -90°F
 4. -110°F
- 6-30. What effect does 3 percent of CO₂ in the atmosphere have on the human body?
1. It causes distorted vision
 2. It causes panting
 3. It causes unconsciousness
 4. It doubles a person's breathing effort
- 6-31. If a person breathed air that had 10 percent CO₂, what would be the effect on the human body?
1. It would cause blurred vision
 2. It would cause panting
 3. It would cause unconsciousness
 4. It would cause marked distress
- 6-32. If a person has been overcome by CO₂, which of the following first aid techniques should be used?
1. Giving artificial resuscitation
 2. Administering oxygen
 3. Keeping them warm
 4. All of the above
- 6-33. A CO₂ recharge unit will pump CO₂ in which of the following forms?
1. Liquid or gas
 2. Liquid only
 3. Gas only
 4. Liquid, gas, or solid
- 6-34. A standard CO₂ supply cylinder will contain approximately how many pounds of liquid CO₂ at a temperature of 70°F?
1. 12
 2. 28
 3. 38
 4. 50
- 6-35. The warmer the supply cylinder, the more efficient will be the transfer operation.
1. True
 2. False
- 6-36. Why is it a recommended procedure to invert the CO₂ supply cylinder when recharging?
1. It will prevent the hose fitting from freezing shut
 2. The CO₂ will remain cooler, allowing it to transfer faster
 3. It allows the syphon tube to accept the gas
 4. It allows the syphon tube to accept the liquid

- 6-37. A hydrostatic test on a CO₂ supply cylinder is good for what maximum period of time?
1. 5 years
 2. 7 years
 3. 3 years
 4. 4 years
- 6-38. DELETED
- 6-39. CO₂ cylinders must be painted what color?
1. Green
 2. Black
 3. Gray
 4. White
- 6-40. All markings on a CO₂ cylinder must be what color?
1. White
 2. Gray
 3. Yellow
 4. Black
- 6-41. Information on a CO₂ cylinder must include which of the following?
1. Tare weight
 2. Gross weight
 3. CO₂ weight
 4. All of the above
- 6-42. If a CO₂ cylinder has a dent exceeding 1/16 inch in depth, what should you do?
1. Declare it RFI and use it
 2. Reject it and return it to supply
 3. Declare it useful until the next hydrostatic test date
 4. Return it to the IMA for further inspection
- 6-43. What action would you take if a CO₂ cylinder showed evidence that it had been in a fire?
1. Refurbish it
 2. Recharge and return it as RFI
 3. Return it to supply
 4. Forward it to NAEC for disposition
- 6-44. To properly record the weight of a CO₂ cylinder, you must use a scale that is graduated in
1. 1/100 lb
 2. 1/1000 lb
 3. 1/100 oz
 4. 1/1000 oz
- 6-45. What is the TARE weight of a CO₂ cylinder?
1. Empty weight with the valve and cable assembly
 2. Empty weight of the cylinder only
 3. Full weight with the valve and cable assembly
 4. Full weight of the cylinder only
- 6-46. What is the weight of the CO₂ charge for an LR-1 life raft cylinder?
1. 0.25 lb
 2. 0.50 lb
 3. 0.75 lb
 4. 1.00 lb
- 6-47. If the cylinder being recharged ceases to gain weight, one of the reasons may be the CO₂ in the supply cylinder is less than what minimum weight?
1. 20 lb
 2. 15 lb
 3. 10 lb
 4. 5 lb
-
- Learning Objective: *Recognize how a CO₂ transfer pump is maintained.*
-
- 6-48. How often should the oil be checked in the CO₂ transfer pump?
1. Daily
 2. Weekly
 3. Biweekly
 4. Monthly

- 6-49. How often should the idler shaft in the CO₂ transfer pump be lubricated?
1. Weekly
 2. Monthly
 3. Every 6 months
 4. Yearly
- 6-50. What lubricant should be used on the idler shaft?
1. Heavy duty cup grease
 2. 10-10 oil
 3. 10-30 oil
 4. Light cup grease
- 6-51. The piston rod should be lubricated with
1. SAE 40 oil
 2. Vaseline
 3. light cup grease
 4. heavy cup grease
- 6-52. How often, if ever, is the commutator lubricated on a CO₂ transfer unit?
1. Monthly
 2. Every 6 months
 3. Yearly
 4. Never
- 6-53. How often, if ever, should the crankcase be serviced?
1. Yearly
 2. Every 2 years
 3. Every 3 years
 4. Never

Assignment 7

Textbook Assignment: "Sewing Machines." Pages 9-1 through 9-39.

Learning Objective: *Identify types, operating characteristics, components, and functions of sewing machines used by the PR.*

- 7-1. Sewing machines are classified as how many basic types?
1. One
 2. Two
 3. Three
 4. Four
- 7-2. Which of the following parts of a sewing machine forms the stitch?
1. Rotary hook
 2. Oscillating shuttle
 3. Both 1 and 2 above
 4. Thread take-up lever
- 7-3. Which of the following types of stitches is most commonly used and made by sewing machines?
1. Lock stitch
 2. Chain stitch
 3. Compound stitch
 4. Either 2 or 3 above, depending on the model of machine
- 7-4. Sewing machines have how many basic parts?
1. One
 2. Two
 3. Three
 4. Four
- 7-5. Material that is being sewn on a sewing machine is held in position by which of the following parts?
1. The needle bar
 2. The pressure foot
 3. The feed dogs
 4. The pressure bar
- 7-6. Which of the following machines is classified as an oscillating machine?
1. 211 w 155
 2. 111 w 151
 3. 111 w 155
 4. 31-15
- 7-7. What is the recommended stitches per minute for the 31-15 machine?
1. 1,500
 2. 2,000
 3. 2,200
 4. 1,800
- 7-8. What is the stitch range of the 31-15 machine?
1. 5-32 spi
 2. 7-32 Spi
 3. 3-15 spi
 4. 4-22 spi
- 7-9. The 31-15 sewing machine can sew canvas up to a maximum of how many ounces?
1. 6
 2. 2
 3. 8
 4. 4
- 7-10. A sewing machine that is in constant use should be oiled how often?
1. Once a day
 2. Twice a day
 3. Everytime the bobbin is changed
 4. Every hour
- 7-11. What type oil is recommended for oiling a sewing machine?
1. 10W mineral
 2. 20W castor base
 3. 3-in-1
 4. SAE 30

- 7-12. How much oil is used on each oiling point on a 13-15 machine?
1. One drop
 2. Two drops
 3. Three drops
 4. Until the oil wick is saturated
- 7-13. What is the proper class and variety of the needle used in the 31-15 machine?
1. 7 x 17
 2. 16 x 87
 3. 31 x 15
 4. 87 x 16
- 7-14. A properly timed needle bar on a 31-15 sewing machine will have the needle bar located so that the point of the shuttle will be how far above the eye of the needle on its upstroke?
1. 1/16 in
 2. 1/32 in
 3. 1/4 in
 4. 1/2 in
- 7-15. Prior to making any adjustments on a sewing machine, a good rule to follow is to do which of the following?
1. Set the stitch length to 0 spi
 2. Check the troubleshooting chart
 3. Set the stitch length to 8 spi
 4. Remove the belt from the clutch pulley
- 7-16. When the point of the needle reaches the material, the feed dogs should be at what position?
1. On the down stroke and even with the throat plate
 2. One full tooth above the throat plate
 3. On the up stroke and even with the throat plate
 4. One full tooth below the throat plate
- 7-17. When adjusting the feed eccentric on the 31-15, the stitch regulator should be set at its lowest position. This is done so the machine will do which of the following?
1. Form its shortest stitch
 2. Prevent any loose movement in the feed eccentric
 3. Form its longest stitch
 4. Prevent the needle from hitting the throat plate
- 7-18. What is the recommended setting of the feed dogs for lightweight material?
1. One full tooth above the throat plate
 2. Slightly more than one tooth above the throat plate
 3. Even with the throat plate
 4. Slightly less than one tooth above the throat plate
- 7-19. When selecting a needle to be used on cloth, which of the following type points would you select?
1. A diamond-shaped point
 2. A sharp round point
 3. A triangle point
 4. A half-round point
- 7-20. Why shouldn't a cutting point needle be used when sewing canopy fabric?
1. It will break the top thread
 2. It will break the bobbin thread
 3. It will cut the warp and filler threads
 4. It will not make a lock stitch
- 7-21. What, if anything, is the purpose of the grooves on both sides of a 16 x 87 sewing machine needle?
1. They prevent the hook from striking the needle
 2. They tell the class and variety of the needle
 3. They serve no purpose
 4. They allow the thread to fall back into the needle when it enters the material

- 7-22. What determines the size of a needle?
1. Diameter of the needle
 2. Needle eye size
 3. Both 1 and 2 above
 4. Thread groove size
- 7-23. What determines the correct size of needle to be used on a project?
1. The type of thread
 2. The size of thread
 3. The material to be sewn
 4. All of the above
- 7-24. What size needle would you use if you were going to sew five plies of nylon using type "E" thread?
1. 18
 2. 20
 3. 21
 4. 24
- 7-25. What size needle should you use to sew elastic webbing?
1. 18
 2. 20
 3. 22
 4. 24
- 7-26. When the bobbin is properly threaded into the bobbin case, the bobbin will turn clockwise when the free end of the thread is pulled.
1. True
 2. False
- 7-27. What should you do to prevent the needle thread from fouling when you start to sew?
1. Backstitch 1/4 in
 2. Backstitch 1/2 in
 3. Hold both threads until you have made two or three stitches
 4. Overstitch 1 in
- 7-28. When regulating the tension on the needle thread, you must remember that the
1. needle bar must be all the way down
 2. presser foot must be up
 3. needle bar must be all the way up
 4. presser foot must be down
- 7-29. A properly formed stitch will have the threads locking in which of the following positions?
1. In the bottom ply of material
 2. In the center of the thickness of material
 3. In the top ply of material
- 7-30. What is used to regulate the pressure on the material?
1. The pressure-regulating thumbscrew
 2. The pressure-regulating hex nut
 3. The pressure-regulating spring
 4. The pressure-regulating disc
- 7-31. If the thread take-up spring is not correctly set, you should loosen the setscrew in the arm of the machine and turn the tension adjusting stud in which direction to lessen the movement of the spring?
1. To the right
 2. To the left
 3. Toward the front
 4. Toward the rear
- 7-32. The class 7-33 sewing machine is intended for what type of work?
1. Sewing light to medium canvas
 2. Sewing light canvas only
 3. Sewing medium canvas
 4. Sewing heavy canvas
- 7-33. What is the difference between the 7-31 and the 7-35 machines?
1. The 7-23 has a clutch on the balance wheel
 2. The 7-31 makes a zigzag stitch
 3. The 7-31 has a clutch on the balance wheel
 4. The 7-35 is a heavy weight machine and the 7-31 is a medium weight machine
- 7-34. To remove the bobbin from the 7-33 sewing machine, you must use the bobbin case release spring.
1. True
 2. False

- 7-35. When replacing the bobbin in the 7-33 sewing machine, you should leave about how many inches of thread hanging free from the shuttle?
1. 2 1/2
 2. 2
 3. 3
 4. 4
- 7-36. The class 111 sewing machines are capable of sewing up to how many stitches per minute?
1. 2,000
 2. 2,200
 3. 3,000
 4. 3,500
- 7-37. Which of the following machines would you use for binding heavy materials?
1. 31-15
 2. 111 W 154
 3. 31-TB
 4. 111 W 150
- 7-38. Which of the following parts of a class 111 sewing machine re-engages the needle with the hook driving assembly after clearing a thread jam?
1. Needle-deflecting hook washer
 2. Rotary hook assembly
 3. Rotary hook saddle
 4. Safety-clutch lock stud
- 7-39. What is the first step in timing a 111 W series sewing machine?
1. Set the eccentric on 0 psi
 2. Set the needle bar
 3. Line up the timing marks
 4. Loosen the needle bar pinch screw
- 7-40. The class 111 W 151 sewing machine has what type of feeding action?
1. Needle drop and alternating presser foot
 2. Needle drop
 3. Compound feed only
 4. Vibrating drop
- 7-41. To set a needle bar that has no timing marks, you must first set the feed eccentric to how many stitches per inch?
1. 0
 2. 2
 3. 6
 4. 8
- 7-42. The eye of the needle should be how far below the sewing hook when it is set properly?
1. 1/8 in
 2. 1/16 in
 3. 3/32 in
 4. 5/16 in
- 7-43. When centering the feeding action, what is the distance between the needle bar and the pressure bar?
1. 1/16 in
 2. 7/32 in
 3. 3/32 in
 4. 17/32 in
- 7-44. The 111 W 152 sewing machine has alternating pressers with a lift of how many inches?
1. 1/2
 2. 2/3
 3. 3/8
 4. 5/16
- 7-45. The 111 W 154 sewing machine has a presser foot lift of how many inches?
1. 1/2
 2. 2/3
 3. 3/8
 4. 17/32
- 7-46. On a 111 W class sewing machine, what would indicate that the bobbin case needs oil?
1. The oil wick
 2. The green felt pad
 3. The black felt pad
 4. The oil reservoir
- 7-47. The needle that is used in a rotary sewing machine has how many parts?
1. 5
 2. 6
 3. 7
 4. 8

- 7-48. How is the bobbin thread tension regulated on a rotary type sewing machine?
1. A thumb screw on the machine face
 2. A small screw on the outside of the bobbin case
 3. An adjusting nut on the bobbin case
 4. A small screw on the feed eccentric
- 7-49. What feature on the 211 W 151 sewing machine prevents damage to the sewing hook?
1. An automatic safety gib
 2. A hook gib
 3. A safety pulley
 4. A safety clutch
- 7-50. What is the maximum speed of the 211 W 151 sewing machine?
1. 3,000 rpm
 2. 3,500 rpm
 3. 3,800 rpm
 4. 4,000 rpm
- 7-51. What needle is used in the 211 W 151 machine?
1. 135 x 17
 2. 135 x 7
 3. Either 1 or 2 above, depending on the lift
 4. 16 x 87
- 7-52. With 1/4 inch clearance under the presser foot, what needle is used on a 211 W 151 sewing machine?
1. 135 x 22
 2. 16 X 87
 3. 135 x 7
 4. 1.35 x 17
- 7-53. What needle would you use with a clearance of 3/8 inch?
1. 1.35 x 22
 2. 16 x 87
 3. 135 x 7
 4. 135 x 17
- 7-54. When setting the needle into a 211 w 151, which direction should the long thread groove face?
1. Right
 2. Aft
 3. Forward
 4. Left
- 7-55. When setting the relative position of the presser and needle bar on a 211 W 151 machine, how much clearance must be maintained?
1. 3/4 in
 2. 17/32 in
 3. 3/16 in
 4. 3/32 in
- 7-56. A properly set feed dog on a 211 W 151 machine will show a full tooth above the throat plate when the feed dog is at its lowest position.
1. True
 2. False
- 7-57. The hook saddle on a 211 W 151 machine is lubricated by which of the following methods?
1. A felt pad
 2. An oiling wick
 3. An oil reservoir
 4. A wool pad
- 7-58. Which of the following sewing machines makes a zigzag stitch?
1. 142 W 151
 2. 143 W 2
 3. 142 W 15
 4. 111 w 143
- 7-59. What is the maximum throw of the 143 W 3 needle bar?
1. 9/16 in
 2. 7/16 in
 3. 5/16 in
 4. 3/16 in
- 7-60. What is the maximum throw of the needle bar on a class 143 W 2 sewing machine?
1. 3/8 in
 2. 5/16 in
 3. 1/4 in
 4. 3/16 in
- 7-61. Which direction does the long thread groove face on the 143 W 3 sewing machine?
1. Forward
 2. Aft
 3. Left
 4. Right

7-62. What type of stitch is formed by a model 99R-3 sewing machine?

1. 302
2. 304
3. 306
4. 308

7-63. What will happen if you turn the zigzag regulating knob clockwise as far as it will go on a model 99R sewing machine?

1. It will make a wider stitch
2. It will make a straight stitch
3. It will sew backwards
4. It will make a narrow stitch

Assignment 8

Textbook Assignment: "Fabrication and Manufacture." Pages 10-1 through 10-30.

Learning Objective: *Use correct terminology when discussing yarns and fabrics.*

- 8-1. What is the basic unit used in the fabrication of textile yarns and fabrics?
1. Staples
 2. Fiber
 3. Yarn
 4. Fillers
- 8-2. What is the edge of material called that has a woven finish to prevent raveling?
1. The material edge
 2. The manufactured edge
 3. The selvage edge
 4. The finished edge
- 8-3. Threads that run lengthwise and parallel to the selvage edge are called what?
1. Warp thread
 2. Filling thread
 3. Locking thread
 4. Basic thread
- 8-4. Which of the following is another name used for filling threads?
1. Woof
 2. Pick
 3. Weft
 4. All of the above
- 8-5. Bias cuts are made at what angle to the filling threads?
1. 180°
 2. 25°
 3. 90°
 4. 45°
- 8-6. Why is a bias cut used to manufacture a parachute?
1. To save material
 2. To prevent tearing between two sections
 3. To provide elasticity
 4. All of the above
- 8-7. What name is given to the force required to break material?
1. Breaking strength
 2. Tensile strength
 3. Warp strength
 4. Filler strength
- 8-8. What determines the weight of cloth?
1. Ounces per running yard
 2. Ounces per square foot
 3. Ounces per square yard
 4. Ounces per running foot
- 8-9. The definition of cloth is any material that is over how many inches from selvage edge to selvage edge?
1. 10
 2. 12
 3. 14
 4. 18
- 8-10. Which of the following is a basic weave?
1. Plain
 2. Twill
 3. Both 1 or 2 above
 4. Warp
- 8-11. Which type of weave gives the smoothest finish and is the easiest to manufacture?
1. Twill
 2. Plain
 3. Warp
 4. Filling

- 8-12. Heat is less damaging to cotton than it is to synthetic fibers.
1. True
 2. False
- 8-13. At approximately 700°F, Nomex fabric will begin to do which of the following?
1. Burn
 2. Melt
 3. Char
 4. Disintegrate
- 8-14. Webbing is defined as material that is less than how many inches from selvage edge to selvage edge?
1. 6
 2. 8
 3. 10
 4. 12
- 8-15. Textile tapes can weigh up to how many ounces per square yard?
1. 3
 2. 10
 3. 15
 4. 20
- 8-16. Depending on the project, either right- or left-twist thread can be used on a sewing machine.
1. True
 2. False

Learning Objective: *Discuss characteristics, specifications, and care of fabrics.*

- 8-17. An ideal storage area for textile material would be dry and out of direct sunlight, with a temperature of how many degrees?
1. 50°F
 2. 60°F
 3. 70°F
 4. 80°F
- 8-18. Exposure to which of the following elements would cause the most serious damage to nylon material?
1. Mildew
 2. Direct sunlight
 3. Fresh water
 4. Salt water

- 8-19. Which of the following factors is/are affected by the air permeability in a parachute assembly?
1. Opening time
 2. Opening force
 3. Stability
 4. All of the above
- 8-20. A length of nylon cord, which is 100 feet long and has an elongation of 10%, can be stretched to what maximum distance without breaking?
1. 110 ft
 2. 120 ft
 3. 130 ft
 4. 140 ft
- 8-21. What does the term "moisture regain" mean when referring to fibers?
1. The percentage of static electricity it absorbs from the air
 2. The percentage of moisture it absorbs from the air
 3. The percentage of static electricity it repels
 4. The percentage of moisture it repels
- 8-22. Military specifications for parachute materials require that, after 50 hours of exposure to sunlight, parachute fabrics should not lose more than what percent of its original strength?
1. 10%
 2. 20%
 3. 25%
 4. 50%
- 8-23. What percentage can nylon be stretched without being damaged?
1. 5 to 25%
 2. 10 to 20%
 3. 15 to 30%
 4. 18 to 40%
- 8-24. What is the percentage of elasticity in nylon?
1. 70%
 2. 75%
 3. 80%
 4. 100%

- 8-25. Nylon has what percent of moisture regain?
1. 2.5
 2. 3.2
 3. 4.2
 4. 5.5
- 8-26. What is the melting point of nylon material?
1. 382°F
 2. 482°F
 3. 540°F
 4. 600°F
-
- Learning Objective: *Identify and discuss special hand tools, grommets, and fasteners.*
-
- 8-27. When installing the chuck and die into a grommet press, the chuck is the upper tool and the die is the lower.
1. True
 2. False
- 8-28. A properly set chuck and die will have a clearance of how many inches?
1. 1/8
 2. 1/32
 3. 1/2
 4. 3/4
- 8-29. A carpenter's square has arm measurements of how many inches?
1. 12 and 24
 2. 14 and 24
 3. 16 and 24
 4. 18 and 24
- 8-30. Which of the following tools is best suited for making holes in material that will use snaps or speedy rivets as fasteners?
1. A hand press
 2. An awl
 3. A star punch
 4. A hot iron
- 8-31. Which of the following sizes of grommets is the smallest?
1. 1
 2. 2
 3. 3
 4. 4
- 8-32. When setting a grommet, the collar size must match the punch size.
1. True
 2. False
- 8-33. When using a grommet set to install a grommet, what should you use to strike the punch?
1. A ballpeen hammer
 2. A rawhide mallet
 3. A setting maul
 4. A hand press
- 8-34. What is the most common type fastener used on clothing?
1. Velcro
 2. Three-way locking
 3. Glove fastener
 4. Curtain fastener
- 8-35. Which of the following type fasteners would you use if you needed extra security?
1. Segma Dot
 2. Durable Dot
 3. Glove
 4. Three-way locking
- 8-36. Three-way locking snaps are supplied in how many sizes?
1. One
 2. Two
 3. Three
 4. Four
- 8-37. Curtain type fasteners are available in how many sizes?
1. One
 2. Two
 3. Three
 4. Four
- 8-38. Which of the following methods is used to clean grease and dirt from a slide fastener?
1. MEK
 2. Toluene
 3. Soap and water
 4. Stoddard solvent

- 8-39. After cleaning a slide fastener, which of the following lubricants should you use to lubricate it?
1. Oil
 2. Graphite
 3. Either 1 or 2 above, depending on the material
 4. Silicone gel
- 8-40. What action should you take if you discover that the bead on a slide fastener is torn?
1. Replace the complete slide fastener
 2. Replace the bead
 3. Replace only the broken side
 4. Repair the bead
- 8-41. To shorten an interlocking slide fastener, the chain should be how much shorter than the opening in the material?
1. 1/2 in
 2. 3/4 in
 3. 1 in
 4. 1 1/2 in
- 8-42. Slide fasteners are available in how many types?
1. One
 2. Two
 3. Three
 4. Four
- 8-43. Slide fasteners are supplied in how many sizes?
1. Six
 2. Five
 3. Three
 4. Four
- 8-44. What grade of slide fastener is made from brass?
1. I
 2. II
 3. III
 4. IV
- 8-45. Why should you use yellow beeswax on hand sewing thread?
1. It contains no oil
 2. To prevent fraying and untwisting
 3. Both 1 and 2 above
 4. To keep the thread from weakening
- 8-46. Which of the following stitches is used to temporarily hold a seam together?
1. Overthrow stitch
 2. Baseball stitch
 3. Running stitch
 4. Basting stitch
- 8-47. Which of the following stitches should you use if a sewing machine is not available?
1. Baseball stitch
 2. Overthrow stitch
 3. Running stitch
 4. Lock stitch 301
- 8-48. Which of the following stitches is used to sew an eyelet onto a parachute container?
1. Baseball stitch
 2. Overthrow stitch
 3. Running stitch
 4. Eyelet stitch
- 8-49. Which hand stitch should you use when a neat appearance is necessary to the seam?
1. Hidden stitch
 2. Lock stitch
 3. Baseball stitch
 4. Basting stitch
- 8-50. What type of needle is used to make a hidden stitch?
1. 1 1/2-inch curved
 2. 2-inch straight
 3. 1 1/2-inch straight
 4. 2 1/2-inch curved

Learning Objective: *Identify hand-sewn seams and stitches.*

Learning Objective: *Identify and discuss machine-sewn stitches and seams.*

8-51. Machine-sewn seams have which of the following advantages over hand-sewn seams?

1. Uniformity of tension
2. Speed
3. appearance
4. All of the above

8-52. Which of the following stitches is a U.S. standard lock stitch?

1. 301
2. 302
3. 303
4. 304

8-53. There are how many classes of seams?

1. One
2. Two
3. Three
4. Four

8-54. What type of seam would you make if you laid one piece of material on top of another and ran a row of stitches down one side?

1. A lapped seam
2. A superimposed seam
3. A bound seam
4. A edge finishing seam

8-55. If your thread should break while sewing a seam, you should start sewing again

1. 1/2 inch behind the break
2. 1/8 inch behind the break
3. 3/4 inch behind the break
4. 1 inch behind the break

Learning Objective: *Select the correct knot for various applications in survival equipment work.*

8-56. What is the simplest knot used to join two cords together?

1. Bowline knot
2. Overhand knot
3. Square knot
4. Binders knot

8-57. Which of the following knots is the most common used to join two cords together?

1. Binders
2. Square
3. Surgeons
4. Half-hitch

8-58. What knot would you use for a safety tie on ripcord pins?

1. Overhand
2. Square
3. Half-hitch
4. Bowline

8-59. Which of the following knots is used to secure the parachute suspension lines to the connector links?

1. Clove hitch
2. Sheepshank
3. Bowline
4. Binder

Assignment 9

Textbook Assignment: "Oxygen Components Test Stands." Pages 11-1 through 11-21.

Learning Objective: *Recognize the properties of oxygen, its density and state according to temperature/pressure conditions, and the adverse effects caused by oxygen deficiency.*

- 9-1. At what minimum altitude is it necessary to use a positive pressure breathing regulator?
1. 18,000 ft
 2. 20,000 ft
 3. 25,000 ft
 4. 35,000 ft
- 9-2. A demand (inhalation) regulator CANNOT supply enough oxygen for the user above what maximum altitude?
1. 32,000 ft
 2. 33,000 ft
 3. 35,000 ft
 4. 43,000 ft
- 9-3. What term is used to describe the condition when the body receives an insufficient amount of oxygen to function properly?
1. Anoxia
 2. Aphyxia
 3. Hypoxia
 4. Suffocation
- 9-4. Which of the following terms refers to a complete lack of oxygen to the body?
1. Anoxia
 2. Asphyxia
 3. Hypoxia
 4. Suffocation
- 9-5. The atmosphere contains about what percentage of oxygen by volume?
1. 10%
 2. 21%
 3. 33%
 4. 23%
- 9-6. Combustion is a form of rapid oxidation. Which of the following examples represents slow oxidation?
1. Rusting iron
 2. Paint turning brittle
 3. Alcohol turning into vinegar
 4. All of the above
- 9-7. The atmosphere contains about what percentage of nitrogen by volume?
1. 21%
 2. 23%
 3. 33%
 4. 78%
- 9-8. What is the weight of 2 gallons of liquid oxygen?
1. 17.00 lb
 2. 19.08 lb
 3. 21.00 lb
 4. 21.08 lb
- 9-9. Liquid oxygen changes to gaseous oxygen at an expansion ratio of
1. 520 to 1
 2. 682 to 1
 3. 862 to 1
 4. 986 to 1
- 9-10. With an applied pressure of 750 psi, at what temperature will oxygen begin to take on its liquid form?
1. -147°F
 2. -182°F
 3. -280°F
 4. -297°F
- 9-11. Oxygen procured by the Navy and tested at a temperature of 70°F must have a purity of 99.5% and a water content of no more than how many milligrams per liter?
1. 0.01
 2. 0.02
 3. 0.03
 4. 0.04

Learning Objective: *Recognize the systems and the operation of the 1172AS100 test stand.*

- 9-12. What is used as the pressure source on the 1172AS100 test stand?
1. Oxygen
 2. Helium
 3. Nitrogen
 4. Argon
- 9-13. The 1172AS100 test stand can evaluate items under test at altitudes of up to how many feet?
1. 50,000
 2. 75,000
 3. 100,000
 4. 150,000
- 9-14. How many on-off valves are incorporated into this test stand?
1. One
 2. Two
 3. Three
 4. Four
- 9-15. The reference pressure selector valve has how many operating positions?
1. One
 2. Two
 3. Three
 4. Four
- 9-16. Which of the following valves indicates inches of water suction?
1. Reference pressure-selector valve
 2. Pressure-selector valve
 3. Leakage-selector valve
 4. Flow-selector valve
- 9-17. What is the principle of operation of a Vol-O-Flo element?
1. Flow pressure
 2. Flow suction
 3. Flow restriction
 4. Flow detection
- 9-18. Where are the Vol-O-Flo elements installed on the 1172AS100 test stand?
1. On control valves and selector valves
 2. Between certain control valves and their indicating manometers
 3. On certain on-off valves and control valves
 4. Between selector valves and their indicating manometers
- 9-19. How many Vol-O-Flo elements are incorporated into the 1172AS100 test stand?
1. One
 2. Two
 3. Three
 4. Four
- 9-20. Which of the following valves allows ambient air pressure into the chamber through the input Vol-O-Flo element?
1. System bleed valve
 2. Chamber bleed valve
 3. Output valve
 4. Input valve
- 9-21. Which of the following valves has a manometer?
1. Flutter dampener
 2. Chamber bleed
 3. Output
 4. System bleed
- 9-22. Why is the vent ambient valve considered an economizer valve?
1. It conserves ambient air
 2. It is used at sea level
 3. It is a nonmeasuring valve
 4. It conserves nitrogen
- 9-23. The proper way to use the shut-off valve is to open it fully, then turn it back how far?
1. 1/8 turn
 2. 1/4 turn
 3. 1/2 turn
 4. 3/4 turn

- 9-24. The high pressure regulator of the 1172AS100 test stand supplies gas to a system from a minimum psig to the maximum psig of the supply cylinder used. The gas is regulated at what minimum psig?
1. 100
 2. 150
 3. 200
 4. 250
- 9-25. What is the range of the input pressure gauge?
1. 0 to 160 psi
 2. 0 to 200 psi
 3. 0 to 2,000 psi
 4. 0 to 3,000 psi
- 9-26. What is the range of the regulated low-pressure gauge?
1. 0 to 160 psi
 2. 0 to 200 psi
 3. 0 to 2,000 psi
 4. 0 to 3,000 psi
- 9-27. What is the range of the pressure/suction manometer?
1. -3.5 to +20.0) in H₂O
 2. -5.5 to +20.0 in H₂O
 3. -9.5 to +22.0 in H₂O
 4. -12.0 to +26.0 in H₂O
- 9-28. What is the range of the high range leakage rotameter?
1. 20 to 200 ccm
 2. 20 to 2,000 psig
 3. 200 to 2,000 ccm
 4. 200 to 2,000 psig
- 9-29. Which of the following formulas is correct?
1. 10 ccm = 1 LPM
 2. 100 ccm = 1 LPM
 3. 1,000 ccm = 1 LPM
 4. 10,000 ccm = 1 LPM
- 9-30. The overboard leakage rotameter is calibrated at 14.7 psig with an ambient air temperature of how many degrees?
1. 60°F
 2. 70°F
 3. 75°F
 4. 80°F
- 9-31. The vacuum pump supplied with the 1172AS100 test stand has the capability of evacuating the chamber at a rate of 22.5 cubic feet per minute at an altitude of how many feet?
1. 43,600
 2. 45,600
 3. 51,600
 4. 54,600
- 9-32. How many prongs are required on the electrical connection plug for the vacuum pump on the 1172AS100 test stand?
1. Two only
 2. Two or three
 3. Three only
 4. Four
-
- Learning Objective: *Identify the maintenance procedures on the 1172AS100 test stand.*
-
- 9-33. What is the specific gravity of the fluid that is used to fill the pressure suction manometer?
1. 1.0
 2. 1.3
 3. 1.7
 4. 1.9
- 9-34. When mixing manometer fluid, the ratio should be 1 part of merian D-2930 to how many parts of distilled water?
1. 0.1
 2. 1.0
 3. 10.0
 4. 100.0
- 9-35. What color manometer fluid is used in the pressure suction manometer?
1. Green
 2. Red
 3. Yellow
 4. Blue
- 9-36. What is the gauge guard cutoff pressure for the regulated low-pressure gauge?
1. 100±5 psig
 2. 145±5 psig
 3. 150±5 psig
 4. 170±5 psig

- 9-37. When performing the altitude chamber and suit simulator tank inward leakage test, you must ascend to 52,000 feet and stabilize for 2 minutes. What is the allowable altitude drop in 20 minutes?
1. 1,000 ft
 2. 2,000 ft
 3. 3,000 ft
 4. 4,000 ft

- 9-38. How often are pressure leakage tests performed on the 1172AS100 test stand?
1. Daily
 2. Weekly
 3. Biweekly
 4. Monthly

Learning Objective: *Identify the operating characteristics and maintenance requirements of the 59A120 liquid oxygen converter test stand.*

- 9-39. Which of the following test stands is used to test LOX converters?
1. OTS 565
 2. LQTS 565
 3. 1172AS100
 4. 59A120

- 9-40. The bell jar assembly on the liquid oxygen converter test stand is used to test items that have more than one area of possible leakage.
1. True
 2. False

- 9-41. When it is operating properly, the relief valve on the bell jar assembly has a range of how many psig?
1. 3 to 5
 2. 5 to 15
 3. 10 to 15
 4. 15 to 30

- 9-42. The relief valve on the bell jar assembly is leaktight at how many psi?
1. 5
 2. 2
 3. 3
 4. 4

- 9-43. At what pressure does the relief valve on the bell jar start to relieve pressure?
1. 5 psi
 2. 10 psi
 3. 15 psi
 4. 20 psi

- 9-44. The converter section of the test stand is protected by the relief valve (RV-11). This valve is set to relieve pressure at how many psig?
1. 15
 2. 50
 3. 100
 4. 110

- 9-45. The differential pressure gauge (DF-1) has a range of how many inches of water pressure?
1. -10 to +50
 2. -50 to +100
 3. 0 to 100
 4. 0 to 150

- 9-46. How many linear flow elements are incorporated into the 59A120 test stand?
1. Five
 2. Six
 3. Three
 4. Four

- 9-47. What is the range of the supply pressure gauge on the 59A120 test stand?
1. 0 to 1,000 psig
 2. 0 to 2,000 psig
 3. 0 to 3,000 psig
 4. 0 to 4,000 psig

- 9-48. The adjustable regulator (R-1) is preset to deliver how much pressure to the test stand through the oxygen supply valve?
1. 90 psig
 2. 160 psig
 3. 180 psig
 4. 300 psig

- 9-49. Which of the following pressure gauges indicates the pressure applied to the item under test?
1. PG-1
 2. PG-2
 3. PG-3
 4. PG-4
- 9-50. Relief valve V-4 prevents excessive pressure buildup in the test stand. At what pressure is this valve leaktight?
1. 90 psig
 2. 120 psig
 3. 140 psig
 4. 160 psig
- 9-51. Relief valve V-4 is set to relieve pressure at how many psig?
1. 90
 2. 120
 3. 160
 4. 180
- 9-52. Linear flow element NIP-3 measures flow rates of how many liters per minute?
1. 0-00.25 LPM
 2. 0-1.0 LPM
 3. 0-50 LPM
 4. 0-150 LPM
- 9-53. The 59A120 test stand is calibrated by the on-site metrology calibration team a minimum of how often?
1. Once a month
 2. Every 6 months
 3. Yearly
 4. Every other year
- 9-54. When setting the oxygen pressure regulator, a minimum of how much pressure is applied to the regulator?
1. 300 psig
 2. 1,000 psig
 3. 1,800 psig
 4. 2,000 psig
- 9-55. How much pressure is set on the pressure regulator (R-1)?
1. 110 psig
 2. 120 psig
 3. 160 psig
 4. 180 psig
- 9-56. When testing the 59A120 test stand for overall leaking, the relief valve (RV-11) should be set to unseat at how many psig?
1. 110
 2. 120
 3. 130
 4. 140
- 9-57. When performing the overall leakage test, any leaking in the system is indicated by a drop in pressure on the test pressure gauge (PG-1). This pressure drop should not be more than how much?
1. 5 psig in 5 min
 2. 5 psig in 10 min
 3. 10 psig in 15 min
 4. 10 psig in 10 min
- 9-58. When the bell jar assembly is tested for leakage, the pressure drop indicated on the differential pressure gauge should not be more than 2 inches of H₂O in how many minutes?
1. 5
 2. 10
 3. 12
 4. 15
- 9-59. What should you use to clean the external parts of the 59A120 test stand?
1. Soap and water
 2. a soft lint-free cloth
 3. Windex
 4. Loxitt
- 9-60. How often are periodic inspections performed on the liquid oxygen converter test stand?
1. Every 20 hours
 2. Every 80 hours
 3. Weekly
 4. Monthly
- 9-61. Which manual would you use to find information on the replacement of the system bleed valve on the 59A120 test stand?
1. NAVAIR 13-1-6.4
 2. NAVAIR 13-1-6.1
 3. NAVAIR 15-17CB-02
 4. NAVAIR 17-1513BC-20

Assignment 10

Textbook Assignment: "Oxygen-Related Components." Pages 12-1 through 12-33.

-
- Learning Objective: *Identify, maintain, and perform maintenance on the CRU-79/P chest-mounted oxygen regulator.*
-
- 10-1. The CRU-79/P regulator has a safety pressure of how many inches of water above the surrounding air pressure?
1. 0.5 to 2.0
 2. 0.50 to 2.5
 3. 0.5 to 5.2
 4. 0.50 to 2.0
- 10-2. Inches of water is a means of measuring the comparatively high pressure used in testing oxygen regulators.
1. True
 2. False
- 10-3. Safety pressure is maintained by the CRU-79/p regulator up to and including what altitude?
1. 50,000 ft
 2. 43,000 ft
 3. 34,000 ft
 4. 25,000 ft
- 10-4. The CRU-79/P regulator has a pressure-breathing feature that will maintain a pressure of up to 18.0 inches of water between what minimum altitudes?
1. 0 to 25,000 ft
 2. 25,000 to 34,000 ft
 3. 34,000 to 50,000 ft
 4. 50,000 to 60,000 ft
- 10-5. DELETED
- 10-6. What is the proper procedure to follow if a CRU-79/P regulator fails any inspection or test requirement?
1. It is repaired at the squadron level
 2. It is repaired at the IMA level
 3. It is repaired at depot level
 4. It is disposed of in accordance with local directives
- 10-7. A special inspection is performed on CRU-79/P regulators at intervals of how many days?
1. 10
 2. 21
 3. 30
 4. 90
- 10-8. CRU79/P regulators are subjected to a calendar inspection at intervals of at least how many days?
1. 30
 2. 90
 3. 120
 4. 220
- 10-9. Which of the following test stands is used to test the CRU-79/P regulator?
1. 59A120
 2. 31TB1995-1
 3. OTS 583
 4. 1172AS100
- 10-10. When you perform the overload test on a CRU-79/P regulator, how many inches of mercury is maintained on the mercury manometer?
1. 1.0
 2. 1.85
 3. 1.30
 4. 1.38

10-11. When you perform the safety pressure test on the CRU-79/P regulator, the safety pressure reading will be indicated by which of the following measurements?

1. Liter per minute
2. Inches in water
3. Pounds per square inch
4. Inches of mercury

10-12. which of the following situations would be the probable cause for a CRU-79/P regulator to start pressure breathing below 35,000 feet?

1. A defective or damaged aneroid assembly
2. The aneroid assembly is too far into the regulator housing
3. The aneroid assembly is too far out of the regulator housing
4. The aneroid sensing diaphragm is installed backwards

10-13. The outlet port of the miniature regulator should never be blocked while pressure is applied to the inlet.

1. True
2. False

Learning Objective: *Identify, maintain and perform maintenance on aircraft panel-mounted oxygen regulators.*

10-14. The panel-mounted regulators incorporate an emergency pressure control lever. Which of the following is NOT a setting for this lever?

1. Emergency
2. 100-percent
3. Test mask
4. Normal

10-15. The low-pressure, panel-mounted regulators have an operating pressure range of how many psig?

1. 50 to 200
2. 50 to 400
3. 50 to 500
4. 50 to 2,000

10-16. A panel-mounted regulator is considered beyond economical repair when the repair cost is more than what percentage of the replacement cost of the regulator?

1. 40%
2. 50%
3. 60%
4. 75%

10-17. A discrepancy found on a CRU-72/A regulator during a transfer inspection should be reported to which of the following work centers?

1. Material control
2. Maintenance control
3. Quality assurance
4. Line division

10-18. Which of the following maintenance activities has the repair capabilities for the panel-mounted regulator?

1. Organizational only
2. Intermediate only
3. Depot only
4. Intermediate and depot

10-19. An acceptance inspection on a CRU-55/A regulator consists of a visual inspection followed by which of the following tests?

1. Outward leak test
2. Inward leak test
3. Functional test
4. Safety pressure test

10-20. To receive oxygen at sea level with an MD-2 regulator, the emergency pressure control lever must be placed in what position?

1. Normal
2. Test mask
3. Emergency

10-21. When you perform a function test on an MD-2 regulator, which of the following indicators would show that the regulator is operating properly?

1. The low-pressure gauge
2. The high-pressure gauge
3. The emergency control lever
4. The flow indicator

- 10-22. Panel-mounted regulators are inspected in accordance with the planned maintenance system (PMS). This inspection CANNOT exceed what maximum number of days?
1. 91
 2. 180
 3. 220
 4. 231
- 10-23. How often, if ever, should the silicone rubber parts be replaced on a MD-1 oxygen regulator?
1. Each time the regulator is disassembled
 2. Each time the regulator is inspected
 3. Each time a function test is performed
 4. Never
- 10-24. Which of the following oxygen systems test stand is used to bench test a panel-mounted regulator?
1. 59A120
 2. 31TB1995-1
 3. 117AS100
 4. OTS 565
- 10-25. Nitrogen supply cylinders used in testing oxygen regulators contain a maximum pressure of how many psig?
1. 2,500 ±200
 2. 2,000 ±200
 3. 1,500 ±200
 4. 2,500 ±110
- 10-26. When you perform an inward leakage test on a panel-mounted regulator. What is the maximum allowable leakage in cubic centimeters per minute?
1. 100
 2. 200
 3. 300
 4. 400
- 10-27. To perform the outlet leakage test on an MD-1 regulator, you must apply a film of leak detection compound over the regulator outlet. The film should not advance more than what minimal distance, if any, to be allowable?
1. 1 inch in 15 seconds
 2. 3/4 inch in 20 seconds
 3. 1/2 inch in 10 seconds
 4. None
- 10-28. What is the allowable leakage, if any, for the overall leakage test?
1. 90 psig in 1 minute
 2. 60 psig in 2 minutes
 3. 80 ccm
 4. None
- 10-29. What is the allowable leakage, if any, for the outward leakage test?
1. 0.12 ccm
 2. 120 lpm
 3. 0.12 lpm
 4. None
- 10-30. When you perform the second Stage relief valve test on a panel-mounted regulator, 3 inches of mercury is applied to the regulator outlet through the vent pressure valve on the test stand. The relief valve should vent at how many liters per minute?
1. 10
 2. 25
 3. 30
 4. 45
- 10-31. When you perform the flow suction test on a panel-mounted regulator, the maximum flow through the regulator, with no suction applied, is how many lpm?
1. 0.01
 2. 0.02
 3. 0.05
 4. 0.10

10-32. What is the proper procedure to follow if a panel-mounted regulator fails the oxygen ratio test?

1. Dispose of it according to local directives
2. Perform an aneroid closure test
3. Perform an emergency pressure test
4. Replace the venturi assembly

10-33. When you perform the aneroid closure test, the aneroid should close within what range?

1. 22,000 and 25,000 feet
2. 25,000 and 28,000 feet
3. 28,000 and 32,000 feet
4. 32,000 and 43,000 feet

10-34. The blinker assembly test ensures that the blinker operates correctly with a demand placed on the regulator. When a flow of 12 lpm is drawn through the regulator, with 17.0 inches of H₂O indicated on the pressure/suction manometer, the blinker should be in what position?

1. Fully closed
2. Half closed
3. One quarter open
4. Fully open

Learning Objective: *Identify, maintain, and perform maintenance on liquid oxygen converters.*

10-35. Liquid oxygen (LOX) is stored at approximately what temperature?

1. -282°F
2. -297°F
3. -282°C
4. -297°F

10-36. The quantity gauge used on a LOX converter indicates the amount of LOX in what units?

1. Pounds
2. Gallons
3. Liters
4. Kilos

10-37. When you fill a LOX converter with the use of a servicing trailer, the converter is considered full when what condition exists?

1. The servicing trailer quantity gauge indicates full
2. The converter capacitance probe indicates full
3. The servicing trailer stops delivering LOX
4. A steady stream of LOX flows from the overboard vent

10-38. At what approximate pressure does the LOX converter pressure closing valve function?

1. 60 psig
2. 75 psig
3. 100 psig
4. 110 psig

10-39. A relief valve is incorporated into LOX systems to prevent excessive pressure buildup. On most LOX systems this relief valve is set to open at approximately how many psig?

1. 50
2. 60
3. 75
4. 110

10-40. Additional protection against over pressurization of a LOX converter installed in an aircraft is a relief valve installed in the aircraft oxygen plumbing. This relief valve is set at approximately how many psig?

1. 110
2. 115
3. 125
4. 130

10-41. When performing the relief valve test, a pressure of 100 to 120 psig is applied to the relief valve. The relief valve should vent a minimum of how many liters per minute?

1. 50
2. 100
3. 150
4. 200

- 10-42. The converter leakage test is performed with the converter pressurized to how many psig?
1. 55
 2. 65
 3. 95
 4. 110
- 10-43. The time required to fill a 10-liter LOX converter at a filling pressure of 30 psig should NOT exceed what maximum number of minutes?
1. 5
 2. 10
 3. 15
 4. 30
- 10-44. A LOX converter should maintain a pressure of 55 to 90 psig while delivering a flow of how many liters per minute?
1. 50
 2. 100
 3. 120
 4. 200
- 10-45. To prevent moisture from entering the converter during shipment or storage, the converter should be pressurized with gaseous oxygen to a maximum pressure of how many psig?
1. 10 to 15
 2. 15 to 25
 3. 25 to 30
 4. 30 to 40
- 10-46. Liquid oxygen converters are subject to a calendar inspection a minimum of every 231 days. This interval applies to which of the following type converters?
1. Aircraft-installed
 2. Shop spares
 3. Servicing pool
 4. All of the above
- 10-47. When performing a bench test on a liquid oxygen converter, the first step is to find the converter's tare weight. To ensure this is done properly, you must use a scale that has a capacity of at least how many pounds?
1. 50
 2. 20
 3. 30
 4. 40
- 10-48. When you measure the outlet temperature of the purging unit, the temperature should be between how many degrees Fahrenheit?
1. 100 and 125
 2. 125 and 150
 3. 150 and 200
 4. 200 and 250
- 10-49. What is the purging time for a 10-liter LOX converter?
1. 30 to 40 minutes
 2. 45 to 75 minutes
 3. 75 to 83 minutes
 4. 85 to 90 minutes
- 10-50. When you purge a LOX converter, what should be the maximum inlet pressure and temperature?
1. 60 psig and 250°F
 2. 55 psig and 200°F
 3. 55 psig and 250°F
 4. 65 psig and 200°F
- 10-51. When you perform an insulation resistance test on an empty converter, the megohmmeter range selector on the test stand is set on what position?
1. Zero
 2. X-1
 3. X-10
 4. X-100
- 10-52. When you perform the capacitance test on an empty converter, the reading on the test stand should be between how many micro-microfarads/
1. 90.3 to 111.5 (UUF)
 2. 110.5 to 121.5 (UUF)
 3. 150.0 to 250.0 (UUF)
 4. 121.5 to 125.5 (UUF)

- 10-53. When you perform the relief valve test on a LOX converter, the relief valve relieves a minimum of how many liters per minute with a pressure of 120 psig applied to the converter?
1. 50
 2. 70
 3. 100
 4. 110
- 10-54. When you perform the fill and buildup time test on a converter, the filling pressure is maintained at how many psig?
1. 30
 2. 50
 3. 60
 4. 70
- 10-55. What is the maximum time it should take to fill a LOX converter, if the proper filling pressure is maintained?
1. 10 minutes
 2. 15 minutes
 3. 20 minutes
 4. 25 minutes
- 10-56. After you have completed the fill test, you should perform a pressure buildup test. What is the required time to buildup a working pressure of 70 to 80 psig?
1. 1 minute
 2. 5 minutes
 3. 10 minutes
 4. 15 minutes
- 10-57. When you perform the capacitance test on a full LOX converter, the capacitance range selector knob is set at which of the following positions?
1. Full
 2. 1x
 3. 10X
 4. 100X
- 10-58. After a period of 24 hours, the evaporation loss should NOT exceed how many pounds of liquid oxygen when the converter is in the buildup and supply mode?
1. 1 lb
 2. 2 lb
 3. 3 lb
 4. 4 lb
- 10-59. When performing the evaporation loss test with the converter in the vented mode, the loss should not exceed how many pounds in 24 hours?
1. 5 lb
 2. 2 lb
 3. 3 lb
 4. 4 lb
- 10-60. When performing the flow test on a liquid oxygen converter, you should apply a flow of 120 lpm. With this flow maintained, the converter should maintain pressures of how many psig?
1. 40 to 55
 2. 55 to 90
 3. 90 to 110
 4. 110 to 115

